

HITACHI PROGRAMMABLE CONTROLLER

IEC 61131-3 Compliant PLC

EHV+

APPLICATION MANUAL

(SERVICE MANUAL)

NJI-564J(X)

○ Warranty period and coverage

The warranty period is the shorter period either 18 months from the date of manufacture or 12 months from the date of installation.

However within the warranty period, the warranty will be void if the fault is due to;

- (1) Incorrect use as directed in this manual and the application manual.
- (2) Malfunction or failure of external other devices than this unit.
- (3) Attempted repair by unauthorized personnel.
- (4) Natural disasters.

The warranty is for the PLC only, any damage caused to third party equipment by malfunction of the PLC is not covered by the warranty.

○ Repair

Any examination or repair after the warranty period is not covered. And within the warranty period ant repair and examination which results in information showing the fault was caused by ant of the items mentioned above, the repair and examination cost are not covered. If you have ant questions regarding the warranty please contact with your supplier or the local Hitachi Distributor. (Depending on failure part, examination might be impossible.)

○ Ordering parts or asking questions

When contacting us for repair, ordering parts or inquiring about other items, please have the following details ready before contacting the place of purchase.

- (1) Model
- (2) Manufacturing number (MFG.No.)
- (3) Details of the malfunction

○ Reader of this manual

This manual is described for the following person.

- Person considering the introduction of PLC
- PLC system engineer
- Person handling PLC
- Manager after installing PLC

Warning

- (1) Reproduction of the contents of this manual, in whole or in part, without written permission of Hitachi-IES, is prohibited.
- (2) The content of this document may be changed without notice.
- (3) While efforts have been made to be accurate, if any wrong or missing information is found, please contact us.

Microsoft® and Windows® are either registered trademarks or trademarks of Microsoft Corporation in the United States and/or other countries.

Safety Precautions

Read this manual and related documents thoroughly before installing, operating, performing preventive maintenance or performing inspection, and be sure to use the unit correctly. Use this product after acquiring adequate knowledge of the unit, all safety information, and all cautionary information. Also, make sure this manual enters the possession of the chief person in charge of safety maintenance.

Safety caution items are classified as “Danger” and “Caution” in this document.



: Identifies information about practice or circumstances, which may lead to personal injury or death, property damage, or economic loss.



: Identifies information about practice or circumstances, which may lead to personal injury, property damage, or economic loss.

However, depending on the circumstances, items marked with



may result in major accidents.

The both marks show important information. Be sure to follow the instructions.

Icons for prohibited items and required items are shown below:



: Identifies prohibition. For example, when open flames are prohibited,



is indicated.



: Identifies requirement. For example, when grounding must be performed,



is indicated.

1. Installation

CAUTION

- Use this product in an environment as described in the catalog or this document.
If this product is used in an environment subject to high temperature, high humidity, excessive dust, corrosive gases, vibration or shock, it may result in electric shock, fire or malfunction.
- Be sure to install the PLC according to this manual. Failure to do so could result in damage by falling off, failure or malfunction.
- Do not allow foreign objects such as wire chips to enter the unit.
They may become the cause of fire, malfunction or failure.

2. Wiring

REQUIRED

- The PLC must be grounded (FE terminal).
Failure to do so could result in injury to personnel or causing it to malfunction.

CAUTION

- Always use the power supply voltage listed in specifications. Using other voltage may damage the equipment or present a risk of fire.
- The wiring operation should be performed by a qualified personnel.
Failure to do so could result in fire, damage or electric shock.

3. Precautions when using the unit

DANGER

- Do not touch the terminals while the power is on.
There is a risk of electric shock.
- Appropriate emergency stop circuit, interlock circuitry and similar safety measures should be added to the PLC system to ensure safety in the event of incorrect, missing or abnormal signals caused by broken signal lines, momentary power interruptions or other causes. Do not share the power supply of relay output module and interlock circuitry because relay output might not work properly due to switching noise from interlock circuitry.

CAUTION

- When performing program change, forced output, RUN, STOP, etc., while the unit is running, be sure to check system safety carefully. Failure to do so could lead to damage to equipment.
- Supply power according to the power-up order.
Failure to do so could lead to damage to equipment or malfunction.

CAUTION

USE POWER SUPPLY UNIT OF EH-PS SERIES FOR SUPPLYING ELECTRIC POWER.

4. Preventive maintenance

 **DANGER**

- Do not connect the (+) and (-) of the battery in reverse polarity. Do not recharge, disassemble, heat, place in fire, or short circuit the battery. There is a risk of explosion or fire.

 **PROHIBITED**

- Do not attempt to disassemble, repair or modify any part of the PLC.
Electric shock, malfunction or failure may result.

 **CAUTION**

- Turn off power to the PLC before mounting or dismounting the module
Electric shock, malfunction or failure may result.

Revision History

No.	Description of revision	Date of revision	Manual number
1	The first edition	Jun. 2010	NJI-564(X)
2	Modbus-TCP/RTU and Global network variables added.	Sep. 2010	NJI-564A(X)
3	.NET framework V3.5 installation added.	Oct. 2010	NJI-564B(X)
4	Note about symbol configuration added.	Aug. 2011	NJI-564C(X)
5	Revised based on release of SP4 version (LINK supported)	Nov. 2011	NJI-564D(X)
6	Special mode added (delete boot project manually).	Feb. 2012	NJI-564E(X)
7	EtherCAT master added.	Oct. 2012	NJI-564F(X)
8	Revised based on release of EHV-CODESYS V3.5 SP3 Patch6	Dec. 2013	NJI-564G(X)
9	Runtime version updated to V3.5 and data memory expanded.	Dec. 2014	NJI-564H(X)
10	Data memory expanded.	Nov. 2015	NJI-564J(X)

Table of Contents

Chapter 1	Introduction	1-1 to 1-2
1.1	Unpacking.....	1-1
1.2	Instruction Manuals.....	1-1
1.3	System overview.....	1-2
Chapter 2	Specifications	2-1 to 2-124
2.1	General Specifications.....	2-1
2.2	Product lineup.....	2-2
2.3	CPU module.....	2-4
2.3.1	Module features.....	2-4
2.3.2	Performance specifications.....	2-6
2.3.3	EtherCAT master specifications.....	2-7
2.3.4	Serial port specifications.....	2-8
2.4	Power supply module.....	2-11
2.5	Base Unit.....	2-14
2.6	I/O Controller.....	2-15
2.7	Digital I/O modules.....	2-16
2.7.1	Overview.....	2-16
2.7.2	Specifications.....	2-19
2.8	Analog I/O Modules.....	2-52
2.8.1	Standard analog modules.....	2-52
2.8.2	High resolution analog modules.....	2-63
2.8.3	Isolated analog modules.....	2-68
2.8.4	RTD input analog module.....	2-73
2.8.5	Thermocouple input analog module.....	2-78
2.9	Special modules.....	2-81
2.9.1	Positioning module : EH-POS.....	2-81
2.9.2	High speed counter module : EH-CU/CUE.....	2-84
2.9.3	Serial interface module : EH-SIO.....	2-89
2.9.4	PROFIBUS-DP module.....	2-92
2.9.5	DeviceNet module.....	2-103
2.9.6	EtherCAT module.....	2-111
2.9.7	CPU Link module.....	2-115
2.10	Accessories.....	2-118
2.10.1	Dummy module: EH-DUM.....	2-118
2.10.2	Expansion cable.....	2-118
2.10.3	Relay terminal block for 32/64-point module.....	2-119
2.10.4	Cable for 32/64-point module.....	2-121
2.10.5	Cable for EM/H-200 series compatible 32-point module.....	2-122
2.10.6	Cable for counter input module.....	2-123
2.10.7	Serial communication cable between PC and PLC.....	2-123
2.10.8	Others.....	2-123

3.1	Installation.....	3-1
3.1.1	Installation of CODESYS/EHV-CODESYS.....	3-1
3.1.2	Installation of USB driver	3-2
3.2	Startup	3-4
3.3	I/O Configuration.....	3-7
3.3.1	Plug Device (I/O configuration).....	3-7
3.3.2	Scan For Devices.....	3-8
3.3.3	Expansion unit	3-9
3.3.4	Update Device	3-10
3.3.5	I/O address	3-11
3.4	I/O-update	3-15
3.5	POU and task.....	3-17
3.6	Variables.....	3-19
3.6.1	Data memory	3-19
3.6.2	Marker memory.....	3-20
3.6.3	Available characters for variable names.....	3-21
3.6.4	Numeric literals	3-21
3.6.5	Data types.....	3-22
3.6.6	Local variable.....	3-23
3.6.7	Global variable	3-24
3.7	Configuration.....	3-25
3.8	Communication settings	3-26
3.9	Programming	3-28
3.10	Login	3-30
3.11	Boot application	3-33
3.12	Source Download / Upload.....	3-34
3.13	Run / Stop / Reset	3-35
3.14	Global network variables	3-36
3.15	Modbus-TCP/RTU	3-39
3.15.1	Introduction	3-39
3.15.2	Modbus-TCP master (client).....	3-40
3.15.3	Modbus-TCP slave (server).....	3-43
3.15.4	Modbus-RTU master.....	3-44
3.16	EH-SIO.....	3-47
3.16.1	Supported function.....	3-47
3.16.2	Port number setting.....	3-47
3.16.3	Modbus-RTU master.....	3-48
3.16.4	General purpose communication.....	3-50
3.16.5	LED indication.....	3-50
3.16.6	Hardware reset and Software reset.....	3-50
3.17	CPU LINK module	3-51
3.17.1	Supported CPU version	3-51
3.17.2	Configuration of LINK parameters	3-52
3.17.3	Declaration of variables	3-53
3.17.4	Configuration of EH-RMP	3-55
3.17.5	Configuration of EH-RMD	3-57
3.17.6	Library of LINK module	3-58

3.18 EtherCAT master function	3-60
3.18.1 Installation of libraries (for EHV-CoDeSys V3.4)	3-60
3.18.2 Supported CPU version	3-61
3.18.3 Configuration.....	3-61
3.18.4 Online settings	3-62
3.18.5 Ethernet speed.....	3-63
3.18.6 Cycle time of EtherCAT task.....	3-63
3.18.7 Programming	3-64
3.18.8 Wiring.....	3-65
3.18.9 Important restrictions	3-65
3.19 Libraries	3-67
3.19.1 How to install.....	3-67
3.19.2 Realtime clock.....	3-68
3.19.3 Serial communication.....	3-69
3.20 Troubleshooting	3-71
3.21 Version.....	3-76
3.22 Notes for version compatibility.....	3-77
3.22.1 Device version	3-77
3.22.2 CPU ROM VER.3.4.1.x with EHV-CoDeSys V3.4 SP4	3-77
3.22.3 Supported Modbus devices	3-78
3.22.4 CPU ROM VER.3.5.4.x.....	3-78

Chapter 4 Installation	4-1 to 4-12
------------------------	-------------

4.1 Installation.....	4-1
4.2 Mounting Module	4-3
4.3 Wiring.....	4-4

Chapter 5 Maintenance	5-1 to 5-4
-----------------------	------------

5.1 Daily and Periodic Inspection	5-1
5.2 Product Life.....	5-2

Appendix Known Restrictions	A-1 to A-4
-----------------------------	------------

MEMO

Chapter 1 Introduction

Thank you very much for choosing Hitachi Programmable Controller (hereinafter referred to as PLC), EHV+ series.

1.1 Unpacking

(1) Installation of a battery

EHV+ series CPU is shipped with a lithium battery installed, but a battery connector is disconnected to prevent unnecessary current consumption. If you need real time clock function or retentive data memory, connect the battery cable to a connector mounted on PCB of CPU module. Refer to “Chapter 5 Maintenance” for further information.

(2) Initializing of user program

Since initial status of memory devices in the CPU is undefined, memory error may be displayed on 7-segment LED at the first power up. In order to initialize memory area, execute “Reset origin” in the first use after connecting a battery.

1.2 Instruction Manuals

I/O modules and communication modules of EH-150 series are available with EHV+ series CPU as listed in page 2-2. Besides this application manual, application manuals are available shown in Table 1.2-1.

Table 1.2-1 Related manuals to EHV+ series CPU

Product name	Model	Type	Application manual number
High-functional modules	EH-PT4	Resistance temperature detective input	NJI-324*(X)
	EH-CU/CUE	High-speed counter	NJI-321*(X)
	EH-POS	Single-axis pulse positioning	NJI-315*(X)
Communication modules	EH-SIO	Serial interface module	NJI-443*(X)
	EH-RMD	DeviceNet master module	NJI-364*(X)
	EH-RMP	Profibus master module	NJI-332*(X)
	EH-RMP2	Profibus master module	NJI-621*(X)
	EH-IOCD/2	DeviceNet slave controller	NJI-364*(X)
	EH-IOCP	Profibus slave controller	NJI-333*(X)
	EH-IOCP2	Profibus slave controller	NJI-612*(X)
	EH-IOCA	EtherCAT slave controller	NJI-599*(X)
EH-(O)LNK	CPU LINK module	NJI-381*(X)	

* The last alphabet of the manual No. stands for version starting from blank, A, B, C...

1.3 System overview

EHV+ series PLC is module type programmable controller shown in Figure 1.3-1.

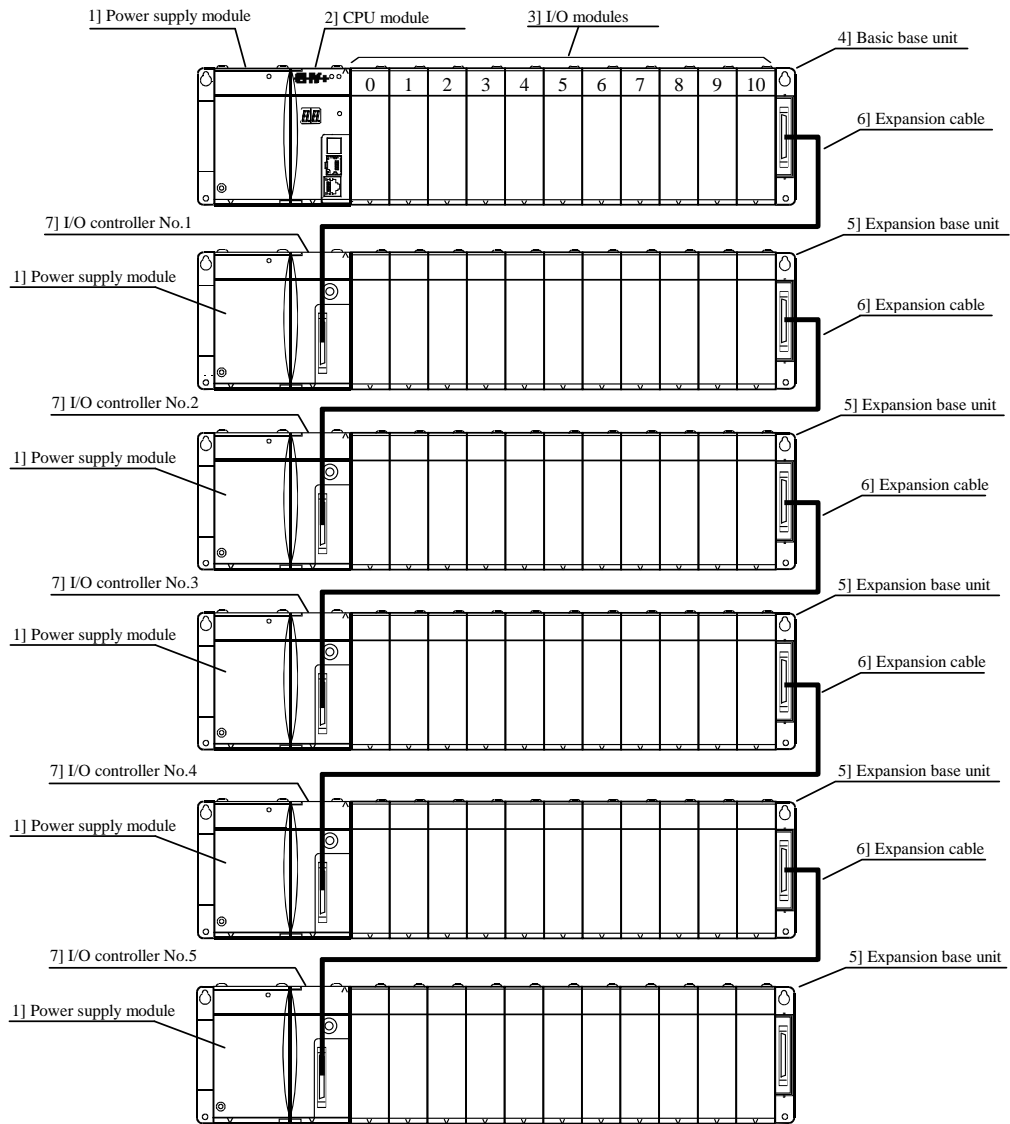

Figure 1.3-1 EHV+ series System configuration diagram (EHV-CPU1102)

No.	Device name	Description of function
1]	Power supply module	Converts external power to DC5V for CPU and I/O modules through base unit.
2]	CPU module	Reads input signals, executes user application program and writes output signals.
3]	I/O module	Many types of I/O modules are available such as digital input/output modules, analog input/output modules, high-functional modules and communicate modules.
4]	Basic base unit	All modules are mounted to base unit. Basic and expansion base unit are common.
5]	Expansion base unit	All modules are mounted to base unit. Basic and expansion base unit are common.
6]	Expansion cable	0.5m, 1m and 2m cable are available. The max. cable length 8m in total.
7]	I/O controller	Be sure to use each expansion base unit.

EHV-CODESYS

EHV-CODESYS is IEC61131-3 compliant programming software for EHV+ series PLC. “CODESYS” is a Trademark of the company 3S-Smart Software Solutions GmbH. “EHV-CODESYS” is same tool as “CODESYS” however, Hitachi specific device description files and libraries are preinstalled.

Chapter 2 Specifications

2.1 General Specifications

Items	Specifications
Operational temperature	0 to 55 °C (* 0 to 45°C)
Storage temperature	− 10 to 75 °C
Operational humidity	5 to 95 % RH (no condensation)
Storage humidity	5 to 95 % RH (no condensation)
Vibration resistance	Conforms to IEC 60068-2-6
Noise resistance	<ul style="list-style-type: none"> ○ Noise voltage 1,500 Vpp, Noise pulse width 100 ns, 1μs (Noise input by a noise simulator across input terminals of a power module according to measuring method of Hitachi-IES. ○ Based on IEC 61131-2 (not applied for input modules) ○ Static noise 3,000 V at electrode part
Certifications	CE
Insulation resistance	20 MΩ minimum between AC terminal and frame ground (FE) terminal (based on 500 V DC megger)
Dielectric withstand voltage	1,500V AC for 1 minute between AC input terminal and frame ground (FE) terminal
Ground	Class D grounding (grounding with the power supply module)
Usage environment	No corrosive gases, no excessive dust
Structure	Open wall-mount type
Cooling	Natural air cooling

* If EH-YR16 is used as UL listed product, max. surrounding temperature rating is 45°C.

2.2 Product lineup

Table 2.2-1 List of system equipment (1 / 2)

Product	Type	Specification	I/O type	Remarks
Power module	EH-PSA	Input 100 to 240V AC, Output 5V DC 3.8 A, 24V DC 0.4 A	—	*1
	EH-PSD	Input 24VDC, Output 5 V DC 3.8 A	—	*1
I/O controller	EH-IOCH2	I/O control module (1 unit / expansion base)	—	*1
Base unit	EH-BS3A	3 I/O modules installed	—	Commonly used for basic or expansion base
	EH-BS5A	5 I/O modules installed	—	
	EH-BS6A	6 I/O modules installed	—	
	EH-BS8A	8 I/O modules installed	—	
	EH-BS11A	11 I/O modules installed	—	
Input module	EH-XD8	8 pts., 24V DC input (response time 5ms)	DI 16	
	EH-XD16	16 pts., 24V DC input (response time 5ms)	DI 16	
	EH-XDL16	16 pts., 24V DC input (response time 16ms)	DI 16	
	EH-XDS16	16 pts., 24V DC input (response time 1ms)	DI 16	
	EH-XD32	32 pts., 24V DC input (response time 5ms)	DI 32	
	EH-XDL32	32 pts., 24V DC input (response time 16ms)	DI 32	
	EH-XDS32	32 pts., 24V DC input (response time 1ms)	DI 32	
	EH-XD32E	32 pts., 24V DC input (response time 1ms), Spring type terminal	DI 32	
	EH-XDL32E	32 pts., 24V DC input (response time 16ms), Spring type terminal	DI 32	
	EH-XD32H	32 pts., 24V DC input (response time 4ms), compatible connector with PIM/H-DM (EM/H-200)	DI 32	
	EH-XD64	64 pts., 24V DC input (response time 1ms)	DI 64	
	EH-XA16	16 pts., 100 to 120V AC input (response time 15ms)	DI 16	
	EH-XAH16	16 pts., 200 to 240V AC input (response time 15ms)	DI 16	
Output module	EH-YR8B	8 pts., Independent relay output, 100/240V AC, 24V DC	DO 16	
	EH-YR12	12 pts., Relay output, 100/240V AC, 24 V DC	DO 16	
	EH-YR16	16 pts., Relay output, 100/240V AC, 24 V DC	DO 16	
	EH-YR16D	16 pts., Relay output, 100/240V AC, 24 V DC, 2-common type	DO 16	
	EH-YT8	8 pts., Transistor output, 12/24V DC (sink type)	DO 16	
	EH-YTP8	8 pts., Transistor output, 12/24V DC (source type)	DO 16	
	EH-YT16	16 pts., Transistor output, 12/24V DC (sink type)	DO 16	
	EH-YTP16	16 pts., Transistor output, 12/24V DC (source type)	DO 16	
	EH-YTP16S	16 pts., Transistor output, 12/24V DC (source type)	DO 16	*3
	EH-YT32	32 pts., Transistor output, 12/24V DC (sink type)	DO 32	*2
	EH-YTP32	32 pts., Transistor output, 12/24V DC (source type)	DO 32	*2
	EH-YT32E	32 pts., Transistor output, 12/24V DC (sink type), Spring type terminal	DO 32	*3
	EH-YTP32E	32 pts., Transistor output, 12/24V DC (source type), Spring type terminal	DO 32	*3
	EH-YT32H	32 pts., Transistor output, 5/12/24V DC (sink type), compatible connector with POM/H-DM (EM/H-200)	DO 32	
	EH-YT64	64 pts., Transistor output, 12/24V DC (sink type)	DO 64	*3
	EH-YTP64	64 pts., Transistor output, 12/24V DC (source type)	DO 64	*3
	EH-YS4	4 pts., Triac output, 100/240V AC	DO 16	
EH-YS16	16 pts., Triac output, 100/240V AC	DO 16		
Analog input module	EH-AX44	12 bits, analog input 8 ch. (4 ch. of 4 to 20 mA, 4 ch. of 0 to 10 V)	AI 8	
	EH-AX8V	12 bits, analog input 8 ch., Voltage (0 to 10 V)	AI 8	
	EH-AX8H	12 bits, analog input 8 ch., Voltage (-10 to +10 V)	AI 8	
	EH-AX8I	12 bits, analog input 8 ch., Current (4 to 20 mA)	AI 8	
	EH-AX8IO	12 bits, analog input 8 ch, Current (0 to 22 mA)	AI 8	
	EH-AXH8M	14 bits, analog input 8 ch. (0 to 22 mA, 4 to 22 mA, -10 to +10 V, 0 to 10 V)	AI 8	
	EH-AXG5M	16 bits, isolated analog input 5 ch. (0 to 22 mA, 4 to 22 mA, -10 to +10 V, 0 to 10 V)	AI 8	

*1 CPU, power module and I/O controller (IOCH2,IOCP/2,IOCD/2, etc.) can be mounted on reserved positions only.

*2 Short circuit protection version is from May 2001 production. (MFG No. 01Exx)

*3 Electric short circuit protection

Table 2.2-1 List of system equipment (2 / 2)

Product	Type	Specification	I/O type	Remarks
Analog output module	EH-AY22	12 bits, analog output 4 ch. (2 ch. of 4 to 20 mA, 2 ch. of 0 to 10 V)	AO 8	
	EH-AY2H	12 bits, analog output 2 ch., Voltage (-10 to +10 V)	AO 8	
	EH-AY4V	12 bits, analog output 4 ch., Voltage (0 to 10 V)	AO 8	
	EH-AY4H	12 bits, analog output 4 ch., Voltage (-10 to +10 V)	AO 8	
	EH-AY4I	12 bits, analog output 4 ch., Current (4 to 20 mA)	AO 8	
	EH-AYH8M	14 bits, analog output 8 ch. (0 to 22 mA, 4 to 22 mA, 0 to 10 V)	AO 8	
	EH-AYG4M	16 bits, isolated analog output 4 ch. (0 to 22 mA, 4 to 22 mA, -10 to +10 V, 0 to 10 V)	AO 8	
RTD input module	EH-PT4	Signed 15 bits, 4 ch. Resistance Temperature Detector input, PT100/PT1000	AI 4	
	EH-RTD8	Signed 15 bits, 6 ch. (3-wire) / 8 ch. (2-wire) Resistance Temperature Detector input, PT100/PT1000	4 AI / 8 AI	
Thermocouple input module	EH-TC8	Signed 15 bits, 8 ch. Thermocouple input (K, E, J, T, B, R, S, N)	AI 8	
High function and communication module	EH-CU	2 ch. high-speed counter input, 100 kHz, 4 points open collector output	EH-CU/E	
	EH-CUE	1 ch. high-speed counter input, 100 kHz, 2 points open collector output	EH-CU/E	
	EH-POS	1 axis pulse output positioning module	EH-POS/4	
	EH-SIO	Serial interface module	EH-SIO	
	EH-RMD	Device Net master module, 256/256 words I/O, 8 units per CPU	EH-LNK	
	EH-RMP	PROFIBUS-DP master module, 256/256 words I/O	EH-LNK	
	EH-RMP2	PROFIBUS-DP master module, 512/512 words I/O	EH-LNK	
	EH-IOCD	Device Net slave controller, 1024 points (128 words) I/O	—	*1
	EH-IOCD2	Device Net slave controller, 1408 points (176 words) I/O	—	*1
	EH-IOCP	PROFIBUS-DP slave controller, 1024 points (128 words) I/O	—	*1
	EH-IOCP2	PROFIBUS-DP slave controller, 1408 points (176 words) I/O	—	*1
	EH-IOCA	EtherCAT slave controller, 1408 points (176 words) I/O	—	*1
	EH-LNK	CPU link module (coaxial), 8 units per CPU	EH-LNK	
	EH-OLNK	CPU link module (optical fiber), 8 units per CPU	EH-LNK	
EH-OLNKG	CPU link module (optical fiber GI50/125 μ m), 8 units per CPU	EH-LNK		
EH-OLNKE	CPU link module (optical fiber GI62.5/125 μ m), 8 units per CPU	EH-LNK		
Dummy module	EH-DUM	Module for empty slot	Empty	
Expansion cables	EH-CB5A	Expansion cable (0.5m)	—	
	EH-CB10A	Expansion cable (1m)	—	
	EH-CB20A	Expansion cable (2m)	—	
Relay terminal	HPX7DS-40V6	Relay terminal block for 32/64-point module	—	
32/64 points module cables	EH-CBM01W	32/64-point module cable, both ends connector (1m)	—	
	EH-CBM03W	32/64-point module cable, both ends connector (3m)	—	
	EH-CBM05W	32/64-point module cable, both ends connector (5m)	—	
	EH-CBM10W	32/64-point module cable, both ends connector (10m)	—	
	EH-CBM01	32/64-point module cable, open and connector end (1m)	—	
	EH-CBM03	32/64-point module cable, open and connector end (3m)	—	
	EH-CBM05	32/64-point module cable, open and connector end (5m)	—	
	EH-CBM10	32/64-point module cable, open and connector end (10m)	—	
	CBM-02	EM/H-200 compatible 32 point module cable, open and connector end (2m)	—	
	CBM-05	EM/H-200 compatible 32 point module cable, open and connector end (5m)	—	
	CBM-10	EM/H-200 compatible 32 point module cable, open and connector end (10m)	—	
Counter module cables	EH-CUC01	Counter module cable, open and connector end (1m)	—	
	EH-CUC02	Counter module cable, open and connector end (2m)	—	
	EH-CUC03	Counter module cable, open and connector end (3m)	—	
	EH-CUC04	Counter module cable, open and connector end (4m)	—	
	EH-CUC05	Counter module cable, open and connector end (5m)	—	
Battery	LIBAT-H	Lithium battery for retentive data and RTC	—	

*1 CPU, power module and I/O controller (IOCH2,IOCP/2,IOCD/2, etc.) can be mounted on reserved positions only.

[Installing restriction]

EH-(O)LNK/RMP/RMP2/RMD can be mounted up to 8 units per CPU. Available position is from slot 0 to 7 of basic base only.

 **Caution**

Due to limited capacity of power supply module, available module configuration depends on total current consumption of mounted modules. Please select I/O module and base unit according to the current consumption specified in following pages.

2.3 CPU module

2.3.1 Module features



Module features								
	<table border="1"> <tr> <td rowspan="2">Type (Weight)</td> <td>EHV-CPU1025 (Approx. 0.2kg (0.4lb.))</td> </tr> <tr> <td>EHV-CPU1102 (Approx. 0.2kg (0.4lb.))</td> </tr> <tr> <td>Current consumption</td> <td>750mA</td> </tr> <tr> <td>Dimensions (mm (in.))</td> <td>  </td> </tr> </table>	Type (Weight)	EHV-CPU1025 (Approx. 0.2kg (0.4lb.))	EHV-CPU1102 (Approx. 0.2kg (0.4lb.))	Current consumption	750mA	Dimensions (mm (in.))	
	Type (Weight)		EHV-CPU1025 (Approx. 0.2kg (0.4lb.))					
		EHV-CPU1102 (Approx. 0.2kg (0.4lb.))						
	Current consumption	750mA						
	Dimensions (mm (in.))							
								
								
Item	Description							
RUN LED	Indicates operation status. (Green lighting: RUN / off: STOP)							
ERR LED	Indicates error status. (Red lighting: Error / Red blinking: Battery error)							
7-segment LED	Indicates error code. Refer to section 3.20 for error code information. 							
E.CLR button	If any error occurs, error code is displayed in 7-segment LED and remains after the error cause is removed. When pressing this button, error code is cleared. If the error cause is still remaining, error code will be displayed again.							

Table 2.3-1 Function specifications

Item	Description
USB communication port	USB port supports gateway function (with EHV-CODESYS) only. USB cable is not included with CPU package nor supplied by Hitachi-IES. Use type-B USB cable.
Serial communication port	<p>Supported function depends on CPU version. V3.4 : IEC programming (Modbus-RTU and general purpose), Gateway (with EHV-CODESYS) V3.5 : IEC programming (Modbus-RTU and general purpose) * Port type can be switched to RS-232C / RS-422 / RS-485 independent from supported function.</p> <div style="display: flex; align-items: center;"> <div style="margin-right: 20px;"> <p>RS-232C setting</p>  <p>[1] SG (—) [2] CD (←) [3] ER1 (→) [4] ER2 (→) [5] SD (→) [6] RD (←) [7] DR (←) [8] RS (→)</p> </div> <div style="margin-right: 20px;"> <p>RS-422 / 485 setting</p> <p>[1] SG (—) [2] N.C. [3] N.C. [4] TX (→) [5] TXN (→) [6] RXN (←) [7] RX (←) [8] N.C.</p> </div> <div> <p>→ : PLC → Host ← : PLC ← Host — : PLC ↔ Host</p> </div> </div> <p>[Note] Be noted that RD LED could light in a moment at power ON/OFF.</p>
Ethernet communication port	Ethernet port has both gateway function (with EHV-CODESYS) and IEC programming function supporting Modbus-TCP client/server and EtherCAT master. In addition, network variables are transferred to/from other EHV+ CPUs over Ethernet network.
RUN / STOP switch	When this switch position is in RUN, CPU start executing program. At the same time, remote controlling is enabled, in which case, CPU is started or stopped by EHV-CODESYS over communication. When this switch position is in STOP. CPU stops executing program. In this status, remote controlling is disabled.
Lock button	Press this button to dismount. Module can be fixed firmly by a screw of M4×10 mm(0.39in.).
Front cover	Open this cover when operating the RUN switch or replacing the battery. Keep the cover closed while the module is running. When the cover is opened, do not touch the printed wiring board.
Battery holder Battery Battery connector	<p>[Battery] Following data are maintained by battery. (1) Data specified as VAR RETAIN and VAR PERSISTENT. (2) RTC (real time clock) data</p> <p>[Note] - Replacement of the lithium battery shall be done by a trained technician only. - Be noted the battery cable is disconnected in factory default to prevent unnecessary battery consumption. - When using the CPU module, check the battery and plug the battery cable as shown above. - The battery has polarity. When plugging in, check the polarity carefully. - Refer to the table on page 5-2 for the life of battery. Replace the battery every two years even when total power failure time is less than the guaranteed value.</p>

 **Caution**

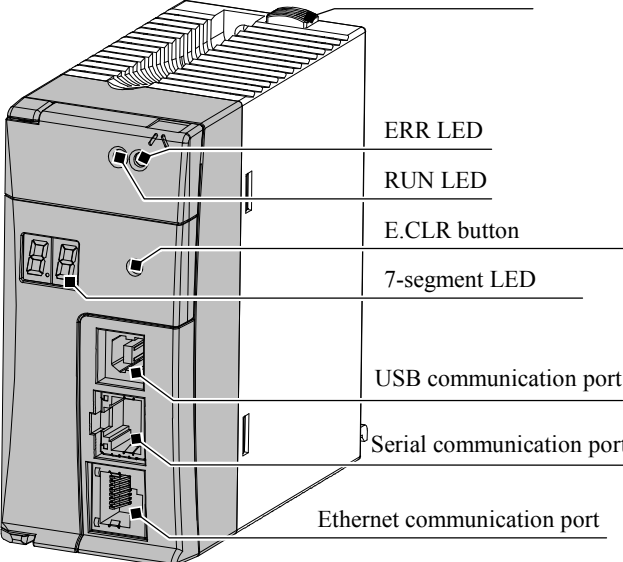
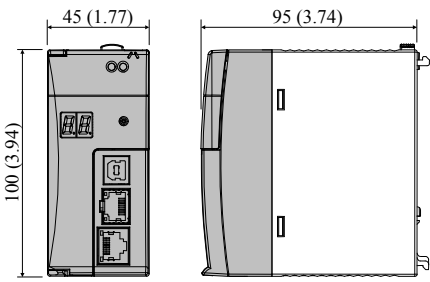
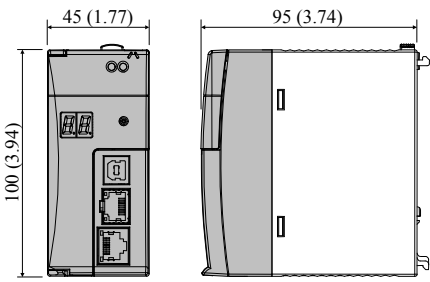
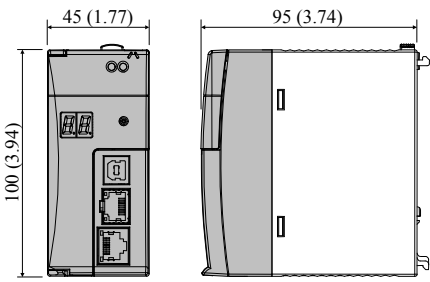
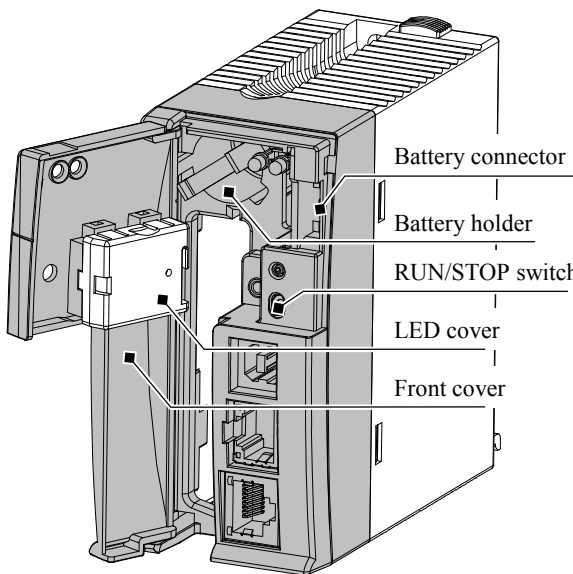
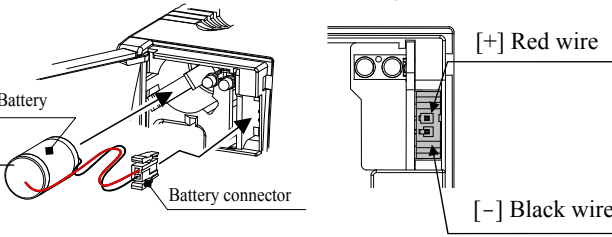
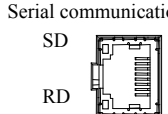
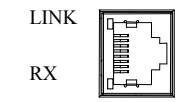
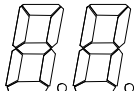
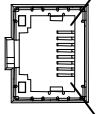
Note the following matters for the communication port.

- (1) Do not connect Ethernet cable to the serial port of CPU module. This could cause damage the CPU or connected equipment.
- (2) In 100BASE-TX (100Mbps) communication of Ethernet, connection could be unstable due to external noise depending on cable length, installation environment and etc. In this case, take following countermeasures.
 - 1] Increase the number of times to retry in connected device.
 - 2] Change Ethernet communication speed to 10Mbps.

Since EtherCAT supports 100Mbps only, communication error might occur depending on installation environment, cable length or external noise. In this case, check your installation environments and take appropriate countermeasures to reduce noise.
- (3) USB communication could be unstable under severe noise environment. Be sure to use short cable and route apart from power line or other communication cables.
- (4) Serial communication in 115.2kbps could be unstable depending on PC. If so, change the baud rate to 57.6kbps or slower.

2.3.2 Performance specifications

Table 2.3-2 Performance specifications

Item	Specification	
	EHV-CPU1025	EHV-CPU1102
		HARDWARE REV.00 to 03
User program memory *3	512KB	2,048KB
Source file memory	4,864KB	
Data memory (non retain)	256KB (V3.4) / 384KB (V3.5)	640KB
Data memory (retain)	12KB (V3.4) / 64KB (V3.5)	128KB
Data memory (persistent)	4KB (V3.4) / 64KB (V3.5)	128KB
Field bus memory or Marker memory	16KB (2KB/slot × 8)	
No. of expansion bases	5	
No. of I/O (using 64 points module)	4,224	
No. of logical port for Gateway *1	4 (V3.4) / 6 (V3.5)	
No. of logical port for NVL *2	4 (V3.5.4.10 or older) / 9 (V3.5.4.11 or newer)	
Programming language	IEC61131-3 compliant 5 languages LD : Ladder Logic Diagram FBD : Function Block Diagram (incl. CFC : Continuous Function Chart) SFC : Sequential Function Chart IL : Instruction List ST : Structured Text	
I/O updating cycle	Refresh processing	
Communication	Protocol	CODESYS V3 protocol
	USB	USB 2.0 Full speed (Gateway *1)
	Ethernet	10BASE-T / 100BASE-TX (Gateway *1, Modbus-TCP client/server, EtherCAT master)
	Serial	RS-232C/422/485 (Modbus-RTU master, General purpose)
Switch, Indications	Indications	RUN LED, ERR LED, 7-segment LED (2 digit)
	RUN switch	STOP / RUN (Remote STOP/RUN enabled when the switch position is RUN.)
	E.CLR button	Reset error information
Calendar / Clock	Support (Built-in RTC)	
Battery	LIBAT-H (for retentive data and Real time clock)	
Maintenance function	Diagnosis (micro processor error, watch dog timer error, memory error, battery error, etc.)	

*1 Gateway : Communication with EHV-CODESYS (Gateway in serial port is not supported by CPU V3.5 or newer version.)

*2 The number of logical ports for NVL (network variable list) is the max. number of network variable lists when the port number of each list is unique. This value depends on usage of other Ethernet communication. If fieldbus (Modbus-TCP/EtherCAT) is used besides NVL, the number of logical port for NVL is reduced accordingly.

*3 Since a boot project contains about 23KB of service information, full size of memory is not available for user program.

Table 2.3-3 Processing speed

Data type (number of bit)	Command	Processing time [μs / IL]
BOOL (1)	OR	0.08
BOOL (1)	AND	0.08
SINT (8)	ADD	0.07
SINT (8)	MUL	0.08
WORD (16)	ADD	0.08
WORD (16)	MUL	0.1
DWORD (32)	ADD	0.1 (V3.4) / 0.07 (V3.5)
DWORD (32)	MUL	0.1 (V3.4) / 0.08 (V3.5)
REAL (32)	ADD	0.9
REAL (32)	MUL	0.9
LREAL (64)	ADD	2.2
LREAL (64)	MUL	2.2

2.3.3 EtherCAT master specifications

Table 2.3-4 EtherCAT master specifications

Items	Specifications
Communication protocol	EtherCAT protocol
Supported services	CoE (process data communications and SDO communications)
Synchronization	None (DC is not supported)
Physical layer	100BASE-TX
Modulation	Baseband
Baud rate	100M bits/s (100BASE-TX)
Duplex mode	Full / Auto
Topology	Daisy chain, branch wiring
Transmission media	Category 5 Shielded twisted-pair cable or higher
Transmission distance	Distance between nodes : 100m or less (IEEE802.3)
Maximum number of slaves	255
Maximum process data size	Input 5,736 bytes, Output 5,736 bytes
Maximum data sizes per slave	Input 1,434 bytes, Output 1,434 bytes
Maximum message size	2,048 bytes
Minimum communications cycle	10 ms
Sync jitter between slaves	1 μ s
Process data communications	PDO mapping using CoE Fail-soft operation for slave communications errors Stop operation for slave communications errors
SDO communications	CoE - Emergency message server (receptions from slaves) - SDO requests and responses
Configuration	Setting node address using EHV-CODESYS network scan Display of network configuration information
RAS functions	Slave configuration check when starting network Reading of error information Trouble shooting information
Slave information	- Automatic reboot of the slaves - Scanning slaves supported
Mailbox support	CoE (CANopen/CAN application layer over EtherCAT) SoE (Servodrive over EtherCAT) FoE (File over EtherCAT) VoE (Vendor over EtherCAT)

Note

- Please note that using various Ethernet based communication (EtherCAT, Modbus-TCP, NVL, Gateway) at the same time will limit the communication performance.
- If connected slave devices are drives (e.g. servo drives), it is strongly recommended to use profile mode in their operation mode. Since EtherCAT cycle of the CPU is not fast enough, cyclic synchronous mode may not work in full performance.

2.3.4 Serial port specifications

(1) RS-232C

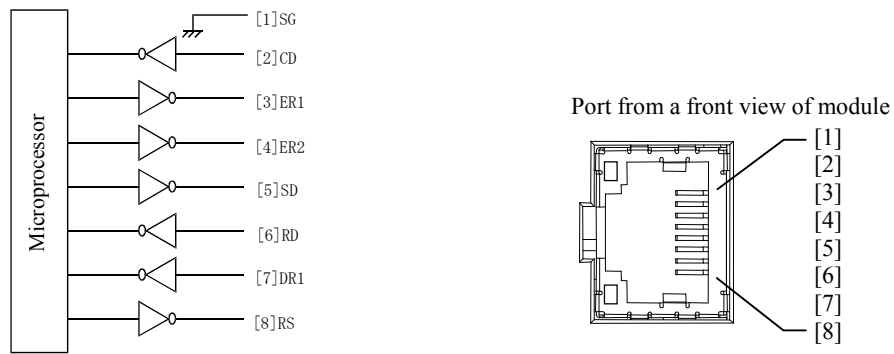

Figure 2.3-1 Circuit diagram and Pin No. of RS-232C

Table 2.3-5 List of signal of RS-232C

Pin No.	Signal name	Direction		Meaning
		CPU	Host	
1	SG	←→	←→	Signal ground
2	CD	←	←	Carrier Detect signal.
3	ER1	→	→	When CPU is ready to communicate, this signal is high.
4	ER2	→	→	Always high
5	SD	→	→	Sending data from CPU
6	RD	←	←	Receiving data to CPU
7	DR	←	←	When this signal is high, connected device is ready to communicate.
8	RS	→	→	When CPU is ready to receive data, this signal is high.

(2) RS-422/485

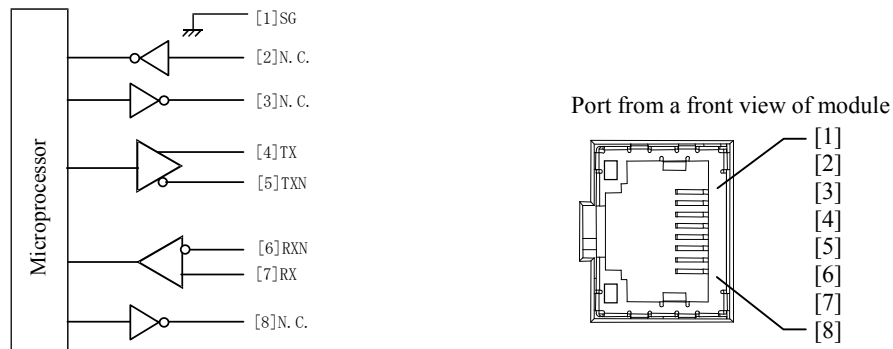

Figure 2.3-2 Circuit diagram and Pin No. of RS-422/485

Table 2.3-6 List of signal of RS-422/485

Pin No.	Signal name	Direction		Meaning
		CPU	Host	
1	SG	←→	←→	Signal ground
2	N.C.	←	←	Unused. Do not connect.
3	N.C.	→	→	Unused. Do not connect.
4	TX	→	→	Sending data (+) from CPU
5	TXN	→	→	Sending data (-) from CPU
6	RXN	←	←	Receiving data (-) to CPU
7	RX	←	←	Receiving data (+) to CPU
8	N.C.	→	→	Unused. Do not connect.

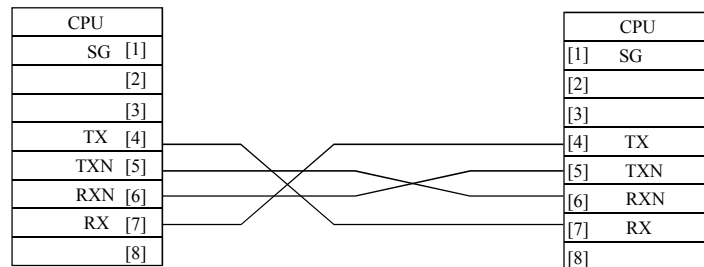

Figure 2.3-3 RS-422 signal connection diagram

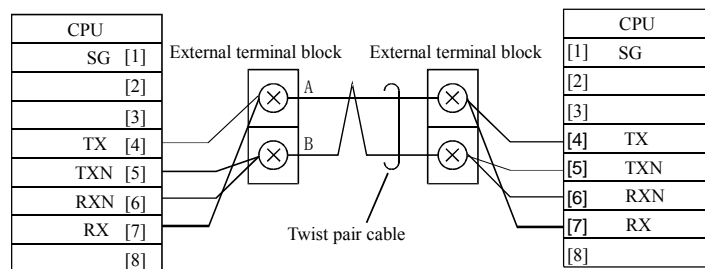

Figure 2.3-4 RS-485 signal connection diagram

Specifications of serial communication port are shown in Table 2.3-7.

Table 2.3-7 Serial port specifications

Item	Specification		
Transmission speed	4,800 / 9,600 / 19,200 / 38,400 / 57,600 / 115,200 bps		
Interface	RS-232C	RS-422	RS-485
Maximum cable length	15 m (16.40 yd.)	500 m (546.81 yd.)	500 m (546.81 yd.)
Connection mode (Maximum connected units)	1 : 1	1 : N (32 units)	1 : N (32 units)
Communication method	Half duplex		
Synchronization method	Start-stop synchronization		
Supported function	General purpose communication, Modbus-RTU master		
Transmission method	Serial transmission (bit serial transmission)		
Transmission code outgoing sequence	Send out from the lowest bit in character units		
Error control	Vertical parity check, sum check, overrun check, framing check.		
Transmission unit	Message unit (variable length)		
Maximum message length	1,024 bytes (including control characters)		

Caution 1:N communication (RS-485)

It is recommended to add about 5 to 20 ms of waiting time between data receiving from devices and data sending from CPU for more stable communication.

Caution Serial communication in 115.2kbps

Serial communication in 115.2kbps could be unstable depending on PC. If so, change the baud rate to 57.6kbps or slower.

Caution Gateway function

Gateway function is not supported by CPU ROM VER.3.5.x.x.

2.4 Power supply module

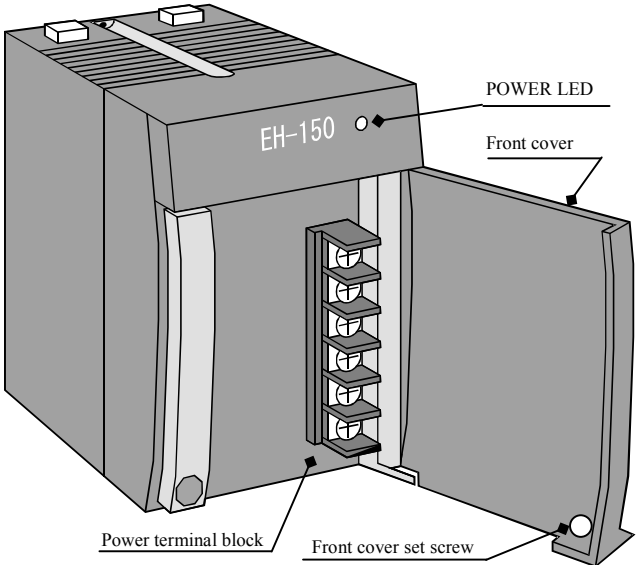
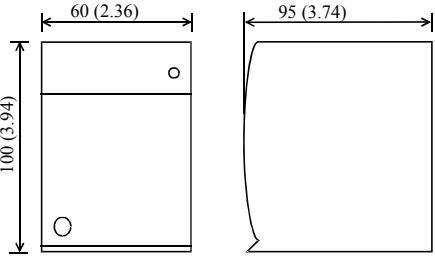
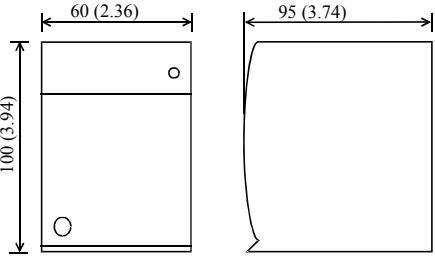
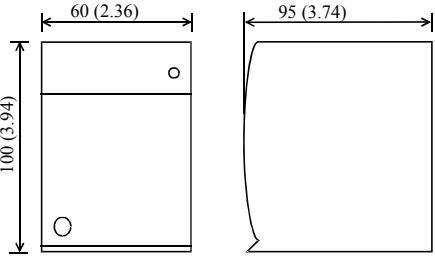
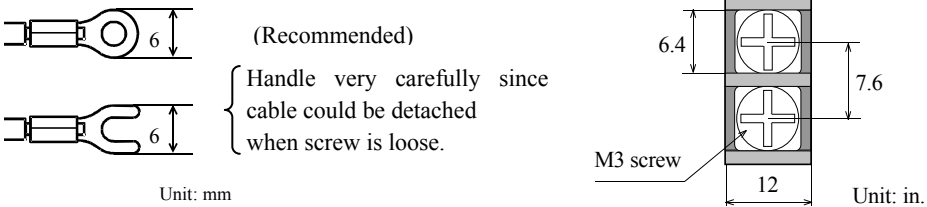
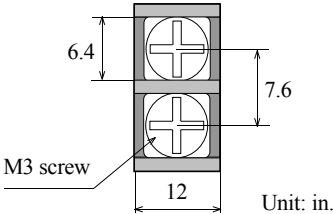
<p>Module features</p> 		<table border="1"> <tr> <td rowspan="2">Type (Weight)</td> <td>EH-PSA (Approx. 0.36kg (0.79lb.))</td> </tr> <tr> <td>EH-PSD (Approx. 0.28kg (0.62lb.))</td> </tr> <tr> <td>Dimensions (mm (in.))</td> <td>  </td> </tr> </table>	Type (Weight)	EH-PSA (Approx. 0.36kg (0.79lb.))	EH-PSD (Approx. 0.28kg (0.62lb.))	Dimensions (mm (in.))	
Type (Weight)	EH-PSA (Approx. 0.36kg (0.79lb.))						
	EH-PSD (Approx. 0.28kg (0.62lb.))						
Dimensions (mm (in.))							
<p>Explanation of function</p>	<p>Power supply module converts externally supplied power into DC5V for CPU and I/O modules via base module and DC24V for output terminals of power supply module.</p> <p>The operating status can be confirmed with the POWER LED on the front of the module.</p> <p>Two types of power supply modules are available, AC type (100 to 240V AC) and DC type (21.6 to 26.4V DC). Refer to a specification table for details.</p>						
<p>Name</p>	<p>Description</p>	<p>Remarks</p>					
<p>POWER LED</p>	<p>AC power supply: LED lighting indicates that the AC power is supplied. LED off indicates that the AC power is not supplied or output of DC power is short-circuit. LED blinking indicates that output current exceeds the limit. DC power supply: LED lighting indicates that the DC power is supplied. LED off indicates that the DC power is not supplied or output of DC power is short-circuit or overvoltage.</p>	<p>LED: green</p>					
<p>Front cover / Front cover set screw</p>	<p>Open this cover when wiring. Keep the front cover closed during operation. Before opening the cover, be sure to remove power to prevent the risk of electric shock. Use M3 × 6 mm (0.24 ft.) screws to fix the cover if necessary.</p>						
<p>Power terminal block</p>	<p>The recommended crimp terminal is indicated below.</p>  <p>Unit: mm</p>  <p>Unit: in.</p>						

(1) EH-PSA

Item	Specification	
Rated input voltage	100/110/120/200/220/240 V AC (50/60Hz)	
Input voltage range	85 to 264 V AC wide range	
Input current	1 A maximum (85 to 264 V AC)	
Input rush current	50 A maximum (Ta=25 °C), 100 A maximum (Ta=55 °C)	
Rated output voltage	5 V DC	24 V DC
Maximum DC output current	3.8 A	0.4 A
Efficiency	65 % minimum (Load of 5V 3.8A 24 V 0.4A after conducting electricity for 5 minutes at room temperature and humidity)	
Output overcurrent protection	Output short-circuit protection	
Allowable momentary power failure	10 ms maximum (85 to 100V AC)	
	20 ms maximum (100 to 264V AC)	
Input leak current	3.5 mA maximum (60 Hz, 264 V AC)	
Dielectric withstand voltage	1 minute at 1,500 V AC between (AC input) and (DC output)	
	1 minute at 750 V AC between (DC output) and (FE)	
Insulation resistance	20 MΩ minimum (500 V DC) (1) Between AC input and FE	
	(2) Between AC input and DC output	
Vibration resistance	Conforms to JIS C 0911 (16.7 Hz double amplitude 3 mm (0.12 in.) X, Y, Z each direction) Conforms to JIS C 0040 (10 to 57 Hz single amplitude 0.075 mm) (57 to 150 Hz constant acceleration 9.8 m/s ²)	
Shock resistance	Conforms to JIS C 0912 (10G, X, Y, Z directions)	
	Conforms to JIS C 0040 (15G, X, Y, Z directions)	

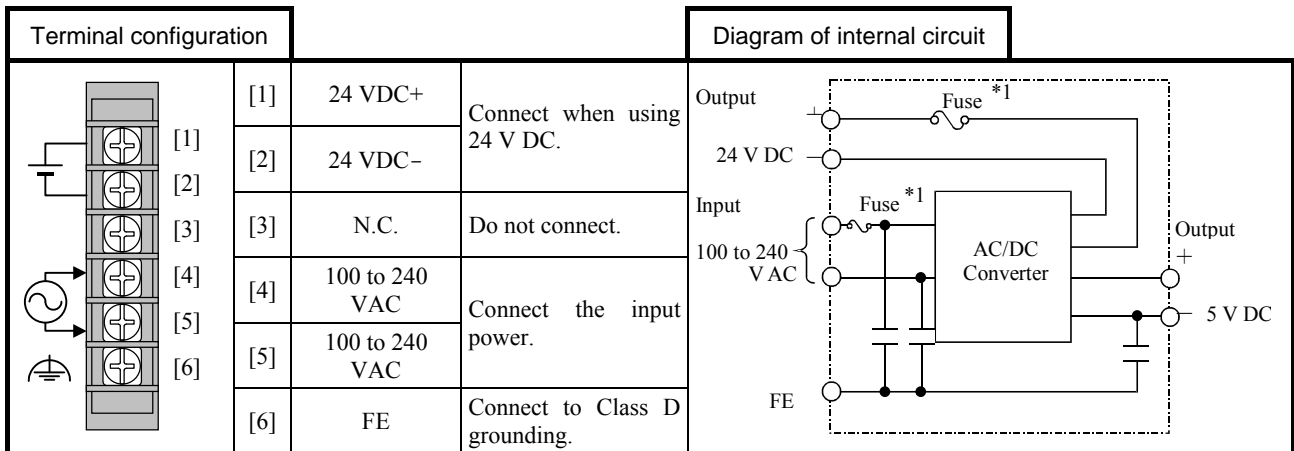

*1 The POWER LED does not light up if the fuse at 24VDC blows. The fuse is not replaced by users. Please contact your local supplier to repair.

(2) EH-PSD

Item	Specification
Rated input voltage	24 V DC
Input voltage range	21.6 to 26.4 V DC
Input current	1.25 A maximum (with 24 V DC)
Input rush current	50 A maximum (Ta=25 °C), 100 A maximum (Ta=55 °C)
Rated output voltage	5 V DC
Maximum DC output current	3.8 A
Efficiency	70 % minimum (Load at 5 V DC 3.8 A)
Output overcurrent protection	Output short-circuit protection
Allowable momentary power failure	1 ms maximum (21.6 to 26.4 V DC)
Dielectric withstand voltage	1 minute at 1,500 V AC between DC input and FE
Insulation resistance	20 MΩ minimum (500 V DC) (Between DC input and FE)
Insulation method	Non insulation

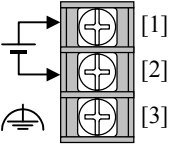
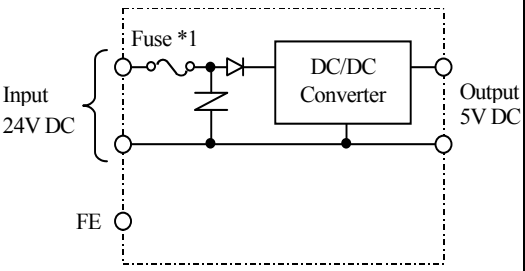
Terminal configuration			Diagram of internal circuit
	[1]	24 VDC+	Connect the input power.
	[2]	24 VDC-	
	[3]	FE	
		Note	Be sure to remove the connection between FE and 24V DC(-) in the insulation resistance measurement and the dielectric withstand voltage test.
			

*1 The POWER LED does not light up if the fuse at 24VDC blows. The fuse is not replaced by users. Please contact your local supplier to repair.

2.5 Base Unit

Module features		Type	EH-BS3A (Approx. 0.22 kg (0.48 lb.))																		
		(Weight)	EH-BS5A (Approx. 0.28 kg (0.62 lb.))																		
			EH-BS6A (Approx. 0.31 kg (0.67 lb.))																		
			EH-BS8A (Approx. 0.36 kg (0.79 lb.))																		
			EH-BS11A (Approx. 0.4 kg (0.87 lb.))																		
		Dimensions (mm (in.))																			
<p>Communication slot (Slot for communication module)</p> <table border="1"> <thead> <tr> <th></th> <th>L1 (Outer dimensions)</th> <th>L2 (Mounted dimensions)</th> </tr> </thead> <tbody> <tr> <td>EH-BS3A</td> <td>222.5</td> <td>207</td> </tr> <tr> <td>EH-BS5A</td> <td>282.5</td> <td>267</td> </tr> <tr> <td>EH-BS6A</td> <td>312.5</td> <td>297</td> </tr> <tr> <td>EH-BS8A</td> <td>372.5</td> <td>357</td> </tr> <tr> <td>EH-BS11A</td> <td>462.5</td> <td>447</td> </tr> </tbody> </table>			L1 (Outer dimensions)	L2 (Mounted dimensions)	EH-BS3A	222.5	207	EH-BS5A	282.5	267	EH-BS6A	312.5	297	EH-BS8A	372.5	357	EH-BS11A	462.5	447		
	L1 (Outer dimensions)	L2 (Mounted dimensions)																			
EH-BS3A	222.5	207																			
EH-BS5A	282.5	267																			
EH-BS6A	312.5	297																			
EH-BS8A	372.5	357																			
EH-BS11A	462.5	447																			
<table border="1"> <tbody> <tr> <td>EH-BS3A</td> <td>all slots</td> </tr> <tr> <td>EH-BS5A</td> <td>all slots</td> </tr> <tr> <td>EH-BS6A</td> <td>all slots</td> </tr> <tr> <td>EH-BS8A</td> <td>all slots</td> </tr> <tr> <td>EH-BS11A</td> <td>only slot 0 to 7 (not available for Slot 8 to A)</td> </tr> </tbody> </table>		EH-BS3A	all slots	EH-BS5A	all slots	EH-BS6A	all slots	EH-BS8A	all slots	EH-BS11A	only slot 0 to 7 (not available for Slot 8 to A)										
EH-BS3A	all slots																				
EH-BS5A	all slots																				
EH-BS6A	all slots																				
EH-BS8A	all slots																				
EH-BS11A	only slot 0 to 7 (not available for Slot 8 to A)																				
Explanation of function	Base unit is one of basic modules for PLC system. Power is supplied from power supply module to CPU and I/O modules via base unit. CPU exchanges data with I/O modules via base unit. Select base unit according to the number of I/O modules for your system.																				
Item	Description																				
Connector for power module	This is a connector to power supply module.																				
Connector for CPU module	This is a connector to CPU module or I/O controller module.																				
Connector for I/O module	This is a connector to I/O module.																				
Expansion cable connector	This is a connector to expansion cable.																				
Mounting hole ×4	Use these holes when installing with screws (M4×20 mm (0.79 in.))																				
Mounting lever for fixing to DIN rail	This is used when mounting to a DIN rail.																				
Cover for expansion cable connector	This cover is used for protecting the expansion cable connector when it is not used.																				

2.6 I/O Controller

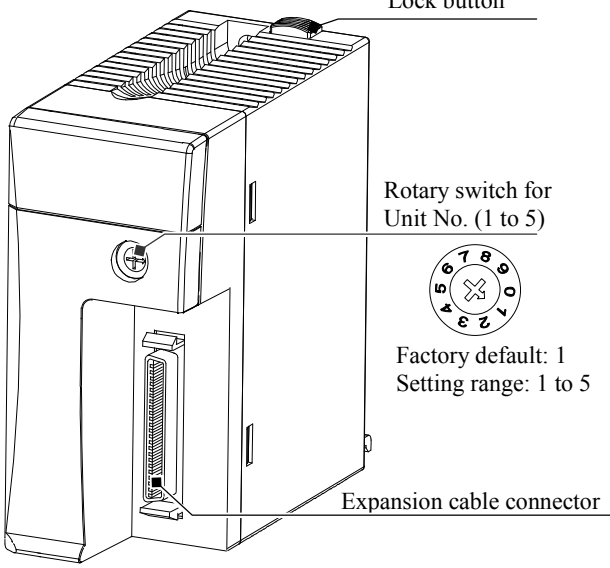
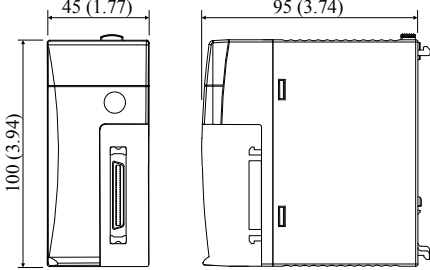

Module features	Type (Weight)	EH-IOCH2 (Approx. 0.14kg (0.31 lb.))
	Dimensions (mm (in.))	
Explanation of function	<p>I/O controller is mounted on CPU's position of an expansion base and controls I/O modules mounted on the same base according to user program in CPU module.</p> <p>Be sure to set unit number with the rotary switch. Unit number must be ascending order from 1 to 5.</p> <p>[Note]</p> <ul style="list-style-type: none"> - Do not set any other number than 1 to 5. - Although EH-IOCH (predecessor) and EH-IOCH2 can be used together, do not use EH-IOCH in the 5th expansion base. EH-IOCH2 must be used in 5th expansion base. 	
Rotary switch for Unit No.	<p>This is a rotary switch for setting the unit No.</p> <p>Please set 1 to 5 from the unit closer to the CPU module in order.</p> <p>Be sure to set without power applied.</p> <p>If unit number is not set properly, it may result in malfunction.</p>	
Expansion cable connector	<p>This is a connector to connect an expansion cable.</p> <p>Connect with the former base unit using the expansion cable.</p>	

2.7 Digital I/O modules

2.7.1 Overview

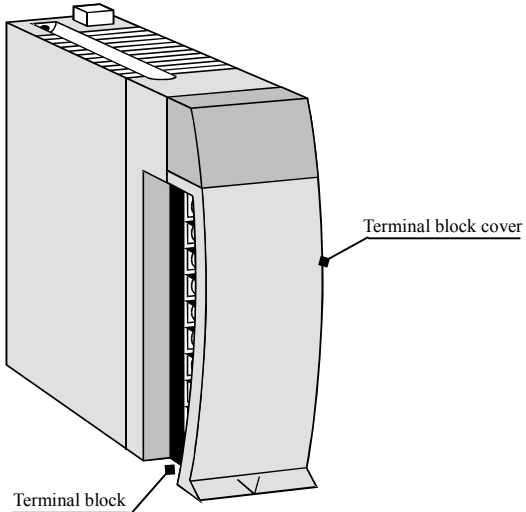
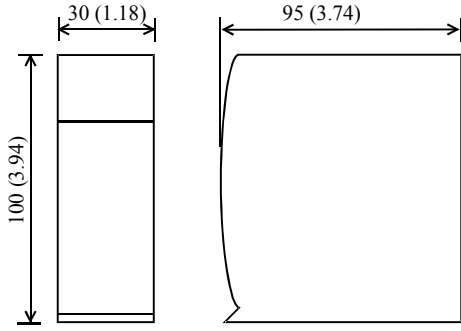
(1) Standard I/O module

<p>Module features</p> 	<p>Type (Weight)</p> <ul style="list-style-type: none"> EH-XD8 (Approx. 0.16kg (0.32lb.)) EH-XD16, XDL16, XDS16 (Approx. 0.16kg (0.32lb.)) EH-XA16, XAH16 (Approx. 0.18kg (0.41lb.)) EH-YT8, EH-YTP8 (Approx. 0.16kg (0.32lb.)) EH-YT16, EH-YTP16 (Approx. 0.16kg (0.32lb.)) EH-YTP16S (Approx. 0.16kg (0.32lb.)) EH-YR8B (Approx. 0.16kg (0.32lb.)) EH-YR12 (Approx. 0.20kg (0.44lb.)) EH-YR16, YR16D (Approx. 0.24kg (0.53lb.)) EH-YS4 (Approx. 0.18kg (0.41lb.)) EH-YS16 (Approx. 0.23kg (0.51lb.))
	<p>Dimensions (mm (in.))</p> 

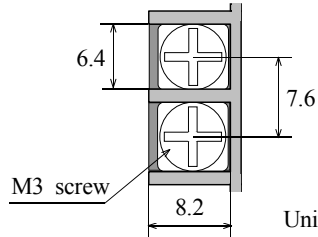
Name	Description
Terminal block	<p>The terminal block is to connect I/O signals. It is removable type. The screw size is M3.</p> <p>Use a suitable sized crimping terminal for the screw. The terminal block supports 0.3 to 2mm² (AWG22 to 14). However, recommended cable is from 0.5 to 0.75mm² (AWG20 to 18). If 2 crimping terminals are connected to one terminal screw, use 0.5mm² (AWG20) cable.</p> <p>The recommended crimping terminal is indicated as below.</p> <div style="display: flex; align-items: center;">  <div style="margin-left: 20px;">(Recommended)</div> </div> <div style="display: flex; align-items: center; margin-top: 10px;">  <div style="margin-left: 20px;"> <p>Handle very carefully since cable could be detached when screw is loose.</p> </div> </div> <p style="text-align: center; margin-top: 5px;">Unit: mm (in.)</p> <div style="display: flex; align-items: center; margin-top: 20px;">  <div style="margin-left: 20px;"> <p>M3 screw</p> <p>Unit: in.</p> </div> </div>
Terminal block cover	This is a cover for installing on the terminal block.

Front view	Indicated contents
	When signal status is ON, LED lights up accordingly.

(2) 32-point I/O module

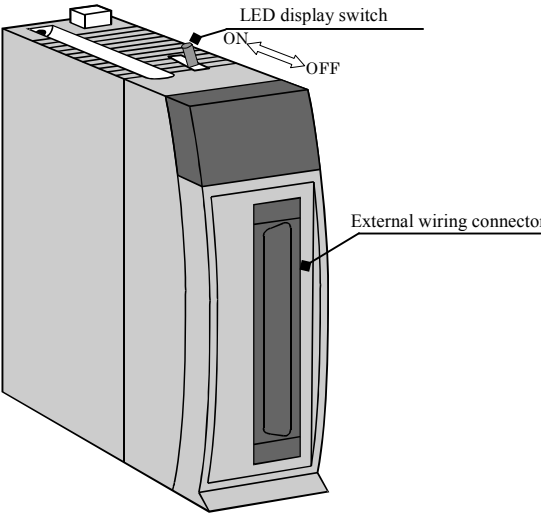
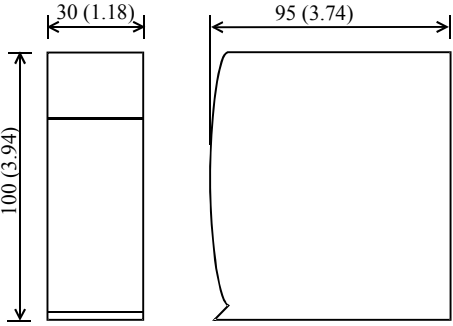
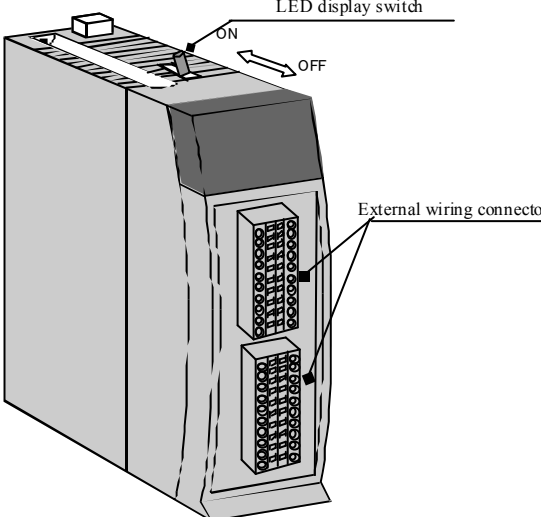
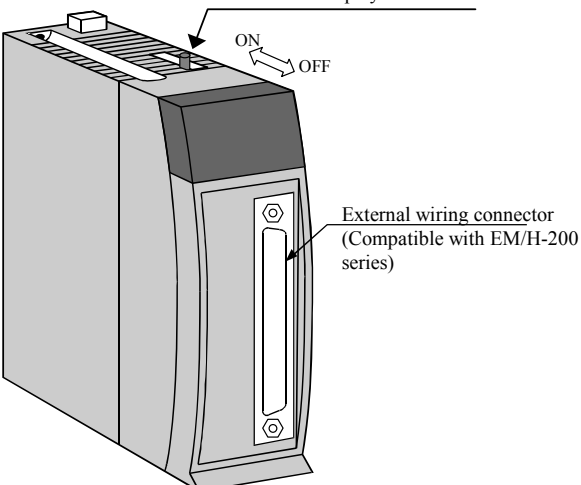
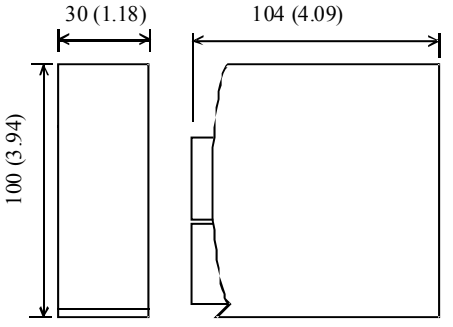
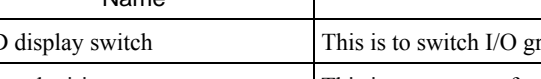
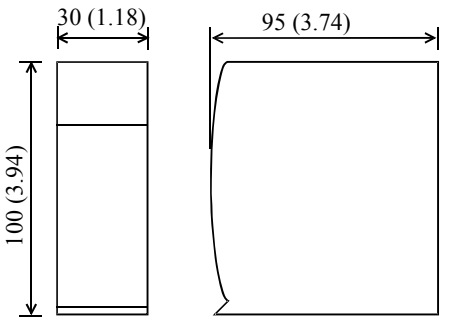
<p>Module features</p>		<p>Type (Weight)</p>	<p>EH-XD32, XDL32, XDS32 (Approx. 0.15kg (0.3lb.))</p>
		<p>Dimensions (mm (in.))</p>	
		<p>Type (Weight)</p>	<p>EH-XD32E, XDL32E (Approx. 0.15kg (0.3lb.))</p>
		<p>Dimensions (mm (in.))</p>	
		<p>Type (Weight)</p>	<p>EH-XD32H (Approx. 0.12kg (0.26lb.))</p>
<p>LED display switch</p>	<p>This is to switch I/O groups to be displayed.</p>	<p>Dimensions (mm (in.))</p>	
<p>External wiring connector</p>	<p>This is a connector for connecting I/O signals.</p>		

Front view	Indicated contents									
	<p>When signal status is ON, LED lights up accordingly. Displayed group can be selected by the LED display switch.</p> <table border="1"> <thead> <tr> <th>SW</th> <th>LED +16</th> <th>Displayed group</th> </tr> </thead> <tbody> <tr> <td>OFF</td> <td>OFF</td> <td>0 to 15</td> </tr> <tr> <td>ON</td> <td>ON</td> <td>16 to 31</td> </tr> </tbody> </table>	SW	LED +16	Displayed group	OFF	OFF	0 to 15	ON	ON	16 to 31
SW	LED +16	Displayed group								
OFF	OFF	0 to 15								
ON	ON	16 to 31								

(3) 64-point I/O module

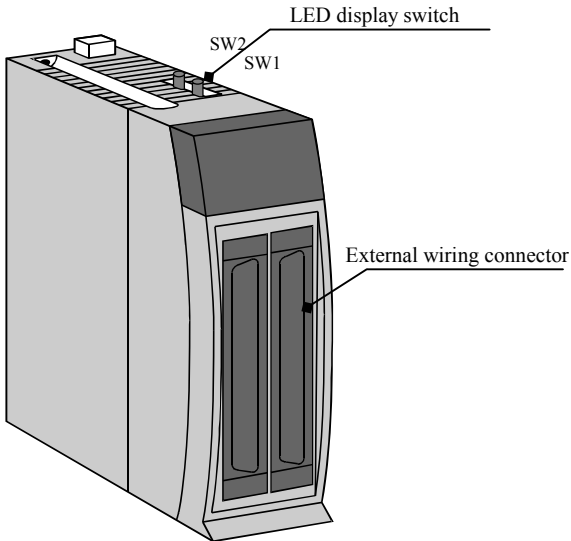
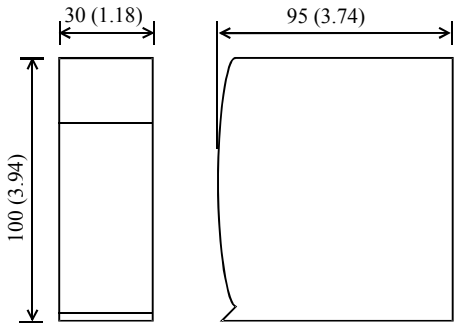
Module features	Type (Weight)	Dimensions (mm (in.))
	EH-XD64 (Approx. 0.14kg (0.31lb.))	
	EH-YT64, YTP64 (Approx. 0.13kg (0.29lb.))	
Item	Description	
LED display switch	This is to switch I/O groups to be displayed.	
External wiring connector	This is a connector for connecting I/O signals.	

Front view	Indicated contents																									
	<p>When signal status is ON, LED lights up accordingly. Displayed group can be selected by the LED display switch.</p> <table border="1"> <thead> <tr> <th>SW1</th> <th>SW2</th> <th>LED 16</th> <th>LED 32</th> <th>Displayed group</th> </tr> </thead> <tbody> <tr> <td>OFF</td> <td>OFF</td> <td>OFF</td> <td>OFF</td> <td>0 to 15</td> </tr> <tr> <td>ON</td> <td>OFF</td> <td>ON</td> <td>OFF</td> <td>16 to 31</td> </tr> <tr> <td>OFF</td> <td>ON</td> <td>OFF</td> <td>ON</td> <td>32 to 47</td> </tr> <tr> <td>ON</td> <td>ON</td> <td>ON</td> <td>ON</td> <td>48 to 63</td> </tr> </tbody> </table>	SW1	SW2	LED 16	LED 32	Displayed group	OFF	OFF	OFF	OFF	0 to 15	ON	OFF	ON	OFF	16 to 31	OFF	ON	OFF	ON	32 to 47	ON	ON	ON	ON	48 to 63
SW1	SW2	LED 16	LED 32	Displayed group																						
OFF	OFF	OFF	OFF	0 to 15																						
ON	OFF	ON	OFF	16 to 31																						
OFF	ON	OFF	ON	32 to 47																						
ON	ON	ON	ON	48 to 63																						

2.7.2 Specifications

(1) EH-XD8

Specification	EH-XD8	
Input type	DC input (common for sink and source)	
Number of inputs	8	
Input voltage	24V DC (19.2 to 30V DC)	
Input current	Approx. 6.9 mA	
Input impedance	Approx. 3.5 kΩ	
Operating voltage	ON voltage	15V minimum
	OFF voltage	5V maximum
Input response time	OFF → ON	5ms maximum
	ON → OFF	5ms maximum
Insulation system	Photo-coupler insulation	
Input display	Green LED	
External connection	Removable type screw terminal block (M3)	
Number of inputs / common	8	
Internal current consumption	30 mA maximum	

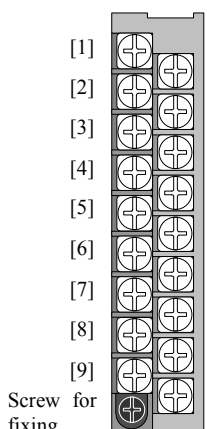
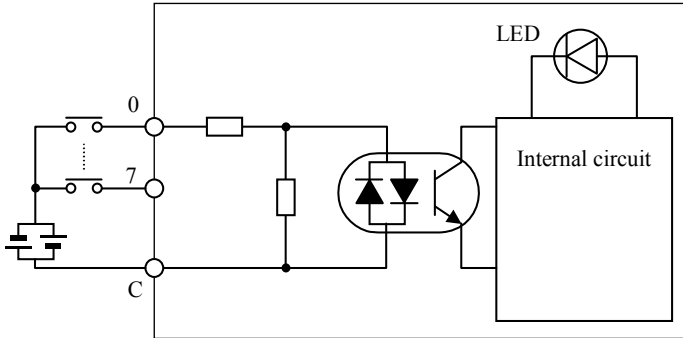
Terminal configuration	No.	Signal name	Diagram of Internal circuit
	[1]	0	
	[2]	1	
	[3]	2	
	[4]	3	
	[5]	4	
	[6]	5	
	[7]	6	
	[8]	7	
	[9]	C	
	[10]	N.C.	
	[11]	N.C.	
	[12]	N.C.	
	[13]	N.C.	
	[14]	N.C.	
	[15]	N.C.	
	[16]	N.C.	
	[17]	N.C.	
	[18]	C	

(2) EH-XD16

Specification		EH-XD16
Input type		DC input (common for sink and source)
Number of inputs		16
Input voltage		24V DC (19.2 to 30V DC)
Input current		Approx. 4.0 mA
Input impedance		Approx. 5.9 kΩ
Operating voltage	ON voltage	15V minimum
	OFF voltage	5V maximum
Input response time	OFF → ON	5ms maximum
	ON → OFF	5ms maximum
Insulation system		Photo-coupler insulation
Input display		Green LED
External connection		Removable type screw terminal block (M3)
Number of inputs / common		16 (1 common, 2 terminals)
Internal current consumption		50 mA maximum

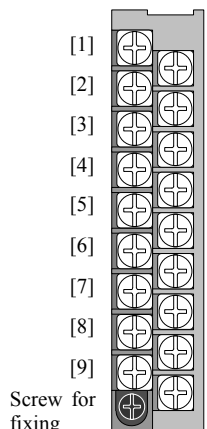
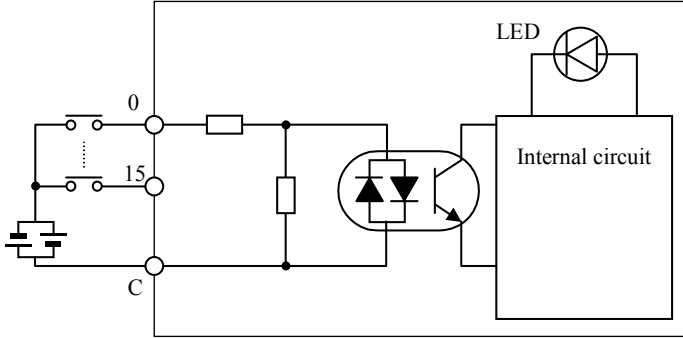
Terminal configuration	No.	Signal name	Diagram of Internal circuit
	[1]	0	
	[2]	1	
	[3]	2	
	[4]	3	
	[5]	4	
	[6]	5	
	[7]	6	
	[8]	7	
	[9]	C	
	[10]	8	
	[11]	9	
	[12]	10	
	[13]	11	
	[14]	12	
	[15]	13	
	[16]	14	
	[17]	15	
	[18]	C	

(3) EH-XDL16

Specification		EH-XDL16
Input type		DC input (common for sink and source)
Number of inputs		16
Input voltage		24V DC (19.2 to 30V DC)
Input current		Approx. 4.0 mA
Input impedance		Approx. 5.9 kΩ
Operating voltage	ON voltage	15V minimum
	OFF voltage	5V maximum
Input response time	OFF → ON	16ms maximum
	ON → OFF	16ms maximum
Insulation system		Photo-coupler insulation
Input display		Green LED
External connection		Removable type screw terminal block (M3)
Number of input points / commons		16 (1 common, 2 terminals)
Internal current consumption		50 mA maximum

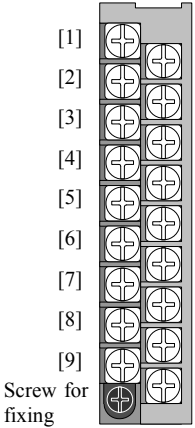
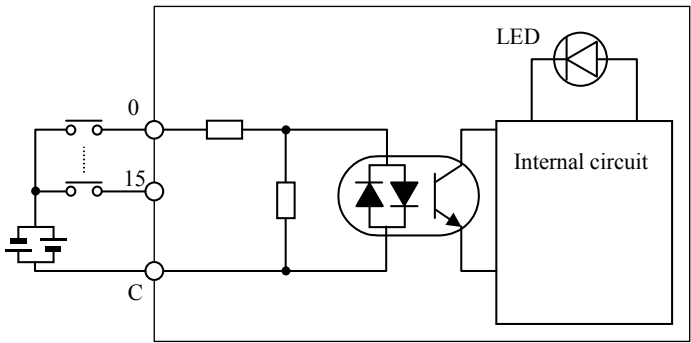
Terminal configuration	No.	Signal name	Diagram of internal circuit
	[1]	0	
	[2]	1	
	[3]	2	
	[4]	3	
	[5]	4	
	[6]	5	
	[7]	6	
	[8]	7	
	[9]	C	
	[10]	8	
	[11]	9	
	[12]	10	
	[13]	11	
	[14]	12	
	[15]	13	
	[16]	14	
	[17]	15	
	[18]	C	

(4) EH-XDS16

Specification		EH-XDS16
Input type		DC input (common for sink and source)
Number of inputs		16
Input voltage		24V DC (19.2 to 30V DC)
Input current		Approx. 4.0 mA
Input impedance		Approx. 5.9 kΩ
Operating voltage	ON voltage	15V minimum
	OFF voltage	5V maximum
Input response time	OFF → ON	1ms maximum
	ON → OFF	1ms maximum
Insulation system		Photo-coupler insulation
Input display		Green LED
External connection		Removable type screw terminal block (M3)
Number of input points / commons		16 (1 common, 2 terminals)
Internal current consumption		50 mA maximum

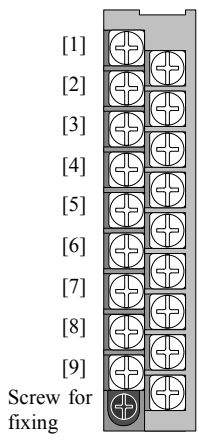
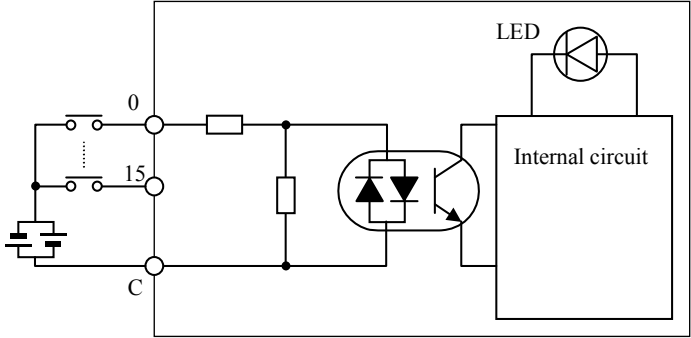
Terminal configuration	No.	Signal name	Diagram of internal circuit
	[1]	0	
	[2]	1	
	[3]	2	
	[4]	3	
	[5]	4	
	[6]	5	
	[7]	6	
	[8]	7	
	[9]	C	
	[10]	8	
	[11]	9	
	[12]	10	
	[13]	11	
	[14]	12	
	[15]	13	
	[16]	14	
	[17]	15	
	[18]	C	

(5) EH-XA16

Specification		EH-XA16
Input type		AC input
Number of inputs		16
Input voltage		100 to 120V AC (85 to 132V AC)
Input current		4.8 to 7.6mA (100V AC / 50Hz)
Input impedance		Approx. 16k Ω (50Hz) / Approx. 13k Ω (60Hz)
Operating voltage	ON voltage	79V AC minimum
	OFF voltage	20V AC maximum
Input response time	OFF \rightarrow ON	15ms maximum
	ON \rightarrow OFF	25ms maximum
Insulation system		Photo-coupler insulation
Input display		Green LED
External connection		Removable type screw terminal block (M3)
Number of inputs / common		16 (1 common, 2 terminals)
Internal current consumption		50 mA maximum

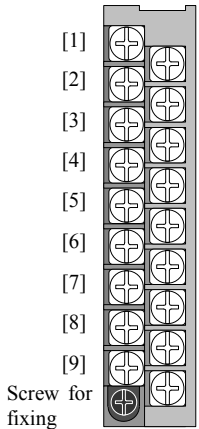
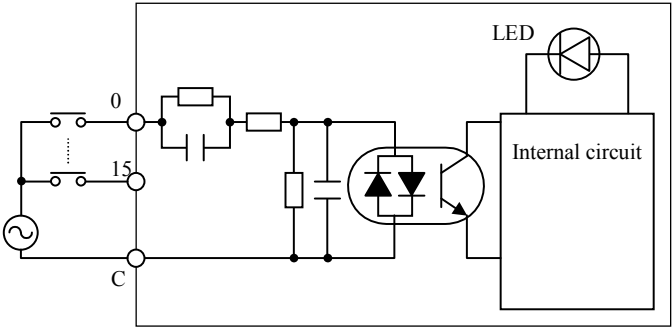
Terminal configuration	No.	Signal name	Diagram of Internal circuit
 <p>Screw for fixing</p>	[1]	0	
	[2]	1	
	[3]	2	
	[4]	3	
	[5]	4	
	[6]	5	
	[7]	6	
	[8]	7	
	[9]	8	
	[10]	9	
	[11]	10	
	[12]	11	
	[13]	12	
	[14]	13	
	[15]	14	
	[16]	15	
	[17]	16	
	[18]	C	

(6) EH-XAH16

Specification		EH-XAH16
Input type		AC input
Number of inputs		16
Input voltage		200 to 240V AC (170 to 264V AC)
Input current		4.3 to 8.0mA (200V AC / 50Hz)
Input impedance		Approx. 32kΩ (50Hz) / Approx. 27kΩ (60Hz)
Operating voltage	ON voltage	164V AC minimum
	OFF voltage	40V AC maximum
Input response time	OFF → ON	15ms maximum
	ON → OFF	25ms maximum
Insulation system		Photo-coupler insulation
Input display		Green LED
External connection		Removable type screw terminal block (M3)
Number of inputs / common		16 (1 common, 2 terminals)
Internal current consumption		50 mA maximum

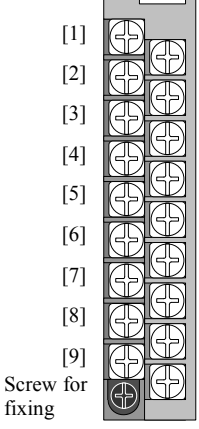
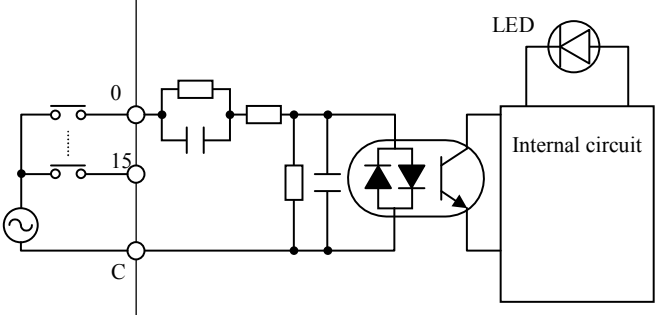
Terminal configuration	No.	Signal name	Diagram of Internal circuit
	[1]	0	
	[2]	1	
	[3]	2	
	[4]	3	
	[5]	4	
	[6]	5	
	[7]	6	
	[8]	7	
	[9]	C	
	[10]	8	
	[11]	9	
	[12]	10	
	[13]	11	
	[14]	12	
	[15]	13	
	[16]	14	
	[17]	15	
	[18]	C	

(7) EH-XD32

Specification	EH-XD32	
Input type	DC input (Common for sink and source)	
Number of inputs	32	
Input voltage	24V DC (20.4 to 28.8 V DC)	
Input current	Approx. 4.3mA	
Input impedance	Approx. 5.6kΩ	
Operating voltage	ON voltage	15V minimum
	OFF voltage	5V maximum
Input response time	OFF → ON	5ms maximum
	ON → OFF	5ms maximum
Insulation system	Photo-coupler insulation	
Input display	Green LED	
External connection	Connector	
Number of inputs / common	32 (1 common, 4 terminals)	
Internal current consumption	60 mA maximum	

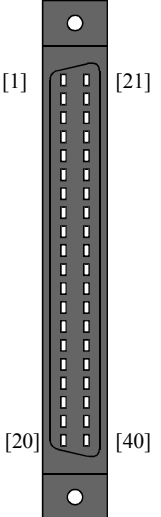
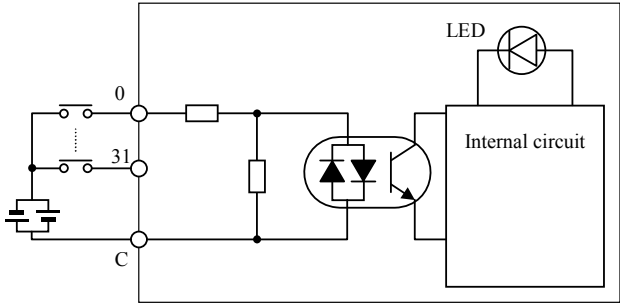
Terminal configuration	No.	Signal name	No.	Signal name	Diagram of Internal circuit
	[1]	0	[21]	16	
	[2]	1	[22]	17	
	[3]	2	[23]	18	
	[4]	3	[24]	19	
	[5]	4	[25]	20	
	[6]	5	[26]	21	
	[7]	6	[27]	22	
	[8]	7	[28]	23	
	[9]	C	[29]	C	
	[10]	8	[30]	24	
	[11]	9	[31]	25	
	[12]	10	[32]	26	
	[13]	11	[33]	27	
	[14]	12	[34]	28	
	[15]	13	[35]	29	
	[16]	14	[36]	30	
	[17]	15	[37]	31	
	[18]	C	[38]	C	
	[19]	N.C.	[39]	N.C.	
	[20]	N.C.	[40]	N.C.	

Applicable connectors

- 120mm (4.73in.) space is required in front of the module. Be sure to consider this space in installation location.
- Use a shield cable with class D grounding.

Manufacturers	Fujitsu Takamizawa	Solder type	Socket: FCN-361J040-AU, Cover: FCN-360C040-E
		Crimp type	Housing: FCN-363J040, Contact: FCN-363J-AU
		Crimp type (flat cable)	FCN-367J040-AU/F
	AMP	Solder type	1473381-1

(8) EH-XDL32

Specification	EH-XDL32	
Input type	DC input (Common for sink and source)	
Number of inputs	32	
Input voltage	24V DC (20.4 to 28.8 V DC)	
Input current	Approx. 4.3mA	
Input impedance	Approx. 5.6kΩ	
Operating voltage	ON voltage	15V minimum
	OFF voltage	5V maximum
Input response time	OFF → ON	16ms maximum
	ON → OFF	16ms maximum
Insulation system	Photo-coupler insulation	
Input display	Green LED	
External connection	Connector	
Number of inputs / common	32 (1 common, 4 terminals)	
Internal current consumption	60 mA maximum	

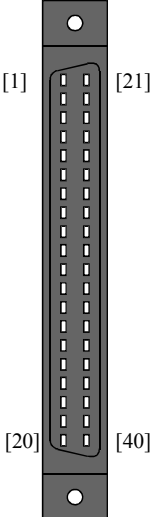
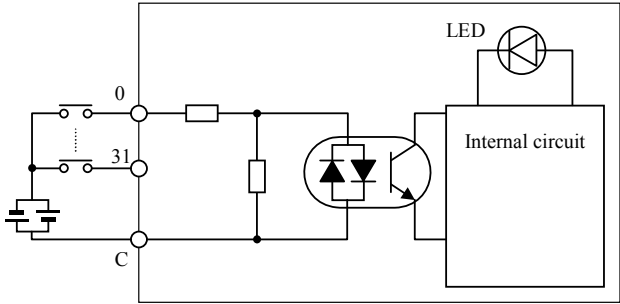
Terminal configuration	No.	Signal name	No.	Signal name	Diagram of Internal circuit
	[1]	0	[21]	16	
	[2]	1	[22]	17	
	[3]	2	[23]	18	
	[4]	3	[24]	19	
	[5]	4	[25]	20	
	[6]	5	[26]	21	
	[7]	6	[27]	22	
	[8]	7	[28]	23	
	[9]	C	[29]	C	
	[10]	8	[30]	24	
	[11]	9	[31]	25	
	[12]	10	[32]	26	
	[13]	11	[33]	27	
	[14]	12	[34]	28	
	[15]	13	[35]	29	
	[16]	14	[36]	30	
	[17]	15	[37]	31	
	[18]	C	[38]	C	
	[19]	N.C.	[39]	N.C.	
	[20]	N.C.	[40]	N.C.	

Applicable connectors

- 120mm (4.73in.) space is required in front of the module. Be sure to consider this space in installation location.
- Use a shield cable with class D grounding.

Manufacturers	Fujitsu Takamizawa	Solder type	Socket: FCN-361J040-AU, Cover: FCN-360C040-E
		Crimp type	Housing: FCN-363J040, Contact: FCN-363J-AU
		Crimp type (flat cable)	FCN-367J040-AU/F
	AMP	Solder type	1473381-1

(9) EH-XDS32

Specification	EH-XDS32	
Input type	DC input (Common for sink and source)	
Number of inputs	32	
Input voltage	24V DC (20.4 to 28.8 V DC)	
Input current	Approx. 4.3mA	
Input impedance	Approx. 5.6kΩ	
Operating voltage	ON voltage	15V minimum
	OFF voltage	5V maximum
Input response time	OFF → ON	1ms maximum
	ON → OFF	1ms maximum
Insulation system	Photo-coupler insulation	
Input display	Green LED	
External connection	Connector	
Number of inputs / common	32 (1 common, 4 terminals)	
Internal current consumption	60 mA maximum	

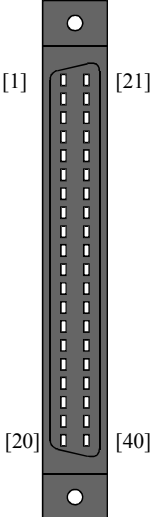
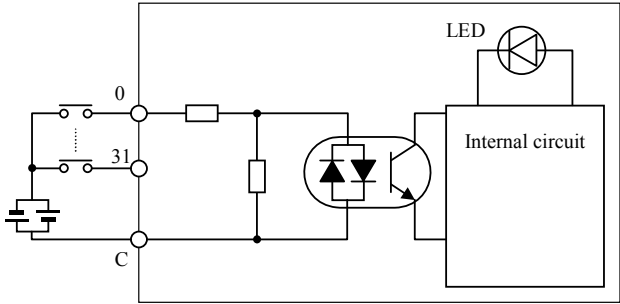
Terminal configuration	No.	Signal name	No.	Signal name	Diagram of Internal circuit
	[1]	0	[21]	16	
	[2]	1	[22]	17	
	[3]	2	[23]	18	
	[4]	3	[24]	19	
	[5]	4	[25]	20	
	[6]	5	[26]	21	
	[7]	6	[27]	22	
	[8]	7	[28]	23	
	[9]	C	[29]	C	
	[10]	8	[30]	24	
	[11]	9	[31]	25	
	[12]	10	[32]	26	
	[13]	11	[33]	27	
	[14]	12	[34]	28	
	[15]	13	[35]	29	
	[16]	14	[36]	30	
	[17]	15	[37]	31	
	[18]	C	[38]	C	
	[19]	N.C.	[39]	N.C.	
	[20]	N.C.	[40]	N.C.	

Applicable connectors

- 120mm (4.73in.) space is required in front of the module. Be sure to consider this space in installation location.
- Use a shield cable with class D grounding.

Manufacturers	Fujitsu Takamizawa	Solder type	Socket: FCN-361J040-AU, Cover: FCN-360C040-E
		Crimp type	Housing: FCN-363J040, Contact: FCN-363J-AU
		Crimp type (flat cable)	FCN-367J040-AU/F
	AMP	Solder type	1473381-1

(10) EH-XD32E

Specification		EH-XD32E
Input type		DC input (Common for sink and source)
Number of inputs		32
Input voltage		24V DC (20.4 to 28.8 V DC)
Input current		Approx. 4.3mA
Input impedance		Approx. 5.6kΩ
Operating voltage	ON voltage	15V minimum
	OFF voltage	5V maximum
Input response time	OFF → ON	1ms maximum
	ON → OFF	1ms maximum
Insulation system		Photo-coupler insulation
Input display		Green LED
External connection		Spring type terminal block (removable)
Number of inputs / common		8 (4 commons, 8 terminals)
Internal current consumption		60 mA maximum

Terminal configuration	No.	Signal name	No.	Signal name	Diagram of Internal circuit
	[1]	0	[21]	16	
	[2]	1	[22]	17	
	[3]	2	[23]	18	
	[4]	3	[24]	19	
	[5]	4	[25]	20	
	[6]	5	[26]	21	
	[7]	6	[27]	22	
	[8]	7	[28]	23	
	[9]	C1	[29]	C3	
	[10]	C1	[30]	C3	
	[11]	8	[31]	24	
	[12]	9	[32]	25	
	[13]	10	[33]	26	
	[14]	11	[34]	27	
	[15]	12	[35]	28	
	[16]	13	[36]	29	
	[17]	14	[37]	30	
	[18]	15	[38]	31	
	[19]	C2	[39]	C4	
	[20]	C2	[40]	C4	
Applicable connectors			Applicable cable		
Manufacturer: Weidmuller Type: B2L3.5/20AUOR Product No.: 175736			0.5mm ² - 1.0mm ² (shared at a twisted pair cable and a single core cable) AWG 28 - 18 Crimping terminal cannot be used.		

(11) EH-XDL32E

Specification	EH-XDL32E	
Input type	DC input (Common for sink and source)	
Number of inputs	32	
Input voltage	24V DC (20.4 to 28.8 V DC)	
Input current	Approx. 4.3mA	
Input impedance	Approx. 5.6kΩ	
Operating voltage	ON voltage	15V minimum
	OFF voltage	5V maximum
Input response time	OFF → ON	16ms maximum
	ON → OFF	16ms maximum
Insulation system	Photo-coupler insulation	
Input display	Green LED	
External connection	Spring type terminal block (removable type)	
Number of inputs / common	8 (4 commons, 8 terminals)	
Internal current consumption	60 mA maximum	

Terminal configuration	No.	Signal name	No.	Signal name	Diagram of Internal circuit
	[1]	0	[21]	16	
	[2]	1	[22]	17	
	[3]	2	[23]	18	
	[4]	3	[24]	19	
	[5]	4	[25]	20	
	[6]	5	[26]	21	
	[7]	6	[27]	22	
	[8]	7	[28]	23	
	[9]	C1	[29]	C3	
	[10]	C1	[30]	C3	
	[11]	8	[31]	24	
	[12]	9	[32]	25	
	[13]	10	[33]	26	
	[14]	11	[34]	27	
	[15]	12	[35]	28	
	[16]	13	[36]	29	
	[17]	14	[37]	30	
	[18]	15	[38]	31	
	[19]	C2	[39]	C4	
	[20]	C2	[40]	C4	
Applicable connectors			Applicable cable		
Manufacturer: Weidmuller Type: B2L3.5/20AUOR Product No.175736			0.5mm ² - 1.0mm ² (Shared at a twisted pair cable and a single core cable.) AWG 28 - 18 Crimping terminal cannot be used.		

(12) EH-XD32H

Item		PIM-DM, PIH-DM (for replacing)	EH-XD32H (This product)
Series		EM/EM- II, H-200/250/252	EH-150
Input specification		DC source input	
Number of inputs		32	
Input voltage		24 V DC (21.6 to 26.0 V DC)	
Input current (24V DC)		Approx. 4.7 mA	Approx. 4.1 mA
Input impedance		Approx. 5.1 k Ω	Approx. 5.9 k Ω
Operating voltage	ON voltage	19 V minimum	
	OFF voltage	7 V maximum	
Input response time	OFF \rightarrow ON	4 ms maximum	
	ON \rightarrow OFF	4 ms maximum	
Insulation method		Photo-coupler insulation	
Number of inputs / common		32 (1 common, 4 terminals)	
Input display		LED (red)	LED (green)
Polarity		Common terminal (+)	
External connection		Connector (50 pins)	
Internal current consumption		20 mA maximum	60 mA maximum

Specification of external wiring connector				Wire
Product name	Manufacturer	Product No.	Connection method	
Plug connector	Hirose Electric Co., Ltd.	DX30-50P	Untie crimping	AWG#30
		DX30A-50P		AWG#28
		DX31-50P	Crimping	AWG#30
		DX31A-50P		AWG#28
		DX40-50P	Soldering	—
Die cast cover		DX-50-CV1	—	—

Terminal configuration	No.	Signal name	No.	Signal name	Diagram of Internal circuit
<p>Note the direction of the connector*1</p>	[25]	NC	[50]	NC	<p>EH-XD32H</p> <p>[Reference] PIM-DM, PIH-DM (for replacing)</p>
	[24]	NC	[49]	NC	
	[23]	NC	[48]	NC	
	[22]	NC	[47]	NC	
	[21]	15	[46]	31	
	[20]	14	[45]	30	
	[19]	13	[44]	29	
	[18]	12	[43]	28	
	[17]	11	[42]	27	
	[16]	10	[41]	26	
	[15]	9	[40]	25	
	[14]	8	[39]	24	
	[13]	NC	[38]	NC	
	[12]	C	[37]	C	
	[11]	NC	[36]	NC	
	[10]	7	[35]	23	
	[9]	6	[34]	22	
	[8]	5	[33]	21	
	[7]	4	[32]	20	
	[6]	3	[31]	19	
	[5]	2	[30]	18	
	[4]	1	[29]	17	
	[3]	0	[28]	16	
	[2]	NC	[27]	NC	
	[1]	C	[26]	C	

*1 The mounted direction of the connector for EH-XD32H is 180 degrees opposite with EM/H-200 series. Plug cable connector with rotating 180 degrees. (It is mechanically not possible to plug in wrong direction.)

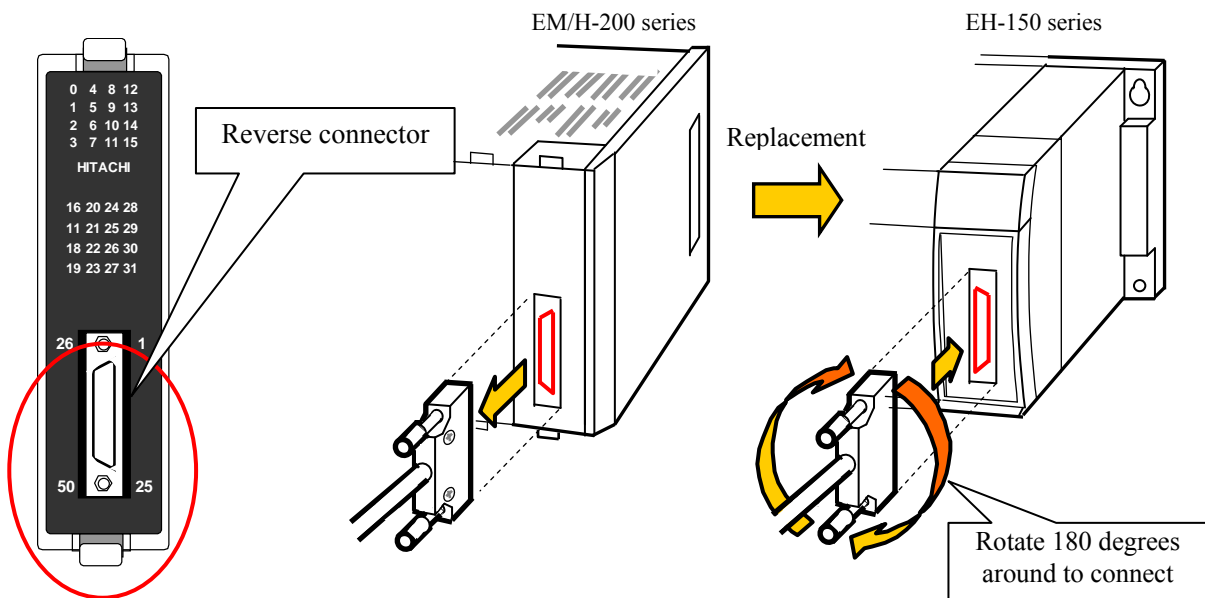

(13) EH-XD64

Specification	EH-XD64	
Input type	DC input (Common for sink and source)	
Number of inputs	64	
Input voltage	24V DC (20.4 to 28.8 V DC)	
Input current	Approx. 4.3mA	
Input impedance	Approx. 5.6kΩ	
Operating voltage	ON voltage	15V minimum
	OFF voltage	5V maximum
Input response time	OFF → ON	1ms maximum
	ON → OFF	1ms maximum
Insulation system	Photo-coupler insulation	
Input display	Green LED	
External connection	Connector	
Number of inputs / common	32 (2 commons, 4 terminals)	
Internal current consumption	80 mA maximum	

Terminal configuration	No.	Signal name	No.	Signal name	No.	Signal name	No.	Signal name	Diagram of Internal circuit
	[41]	32	[61]	48	[1]	0	[21]	16	
	[42]	33	[62]	49	[2]	1	[22]	17	
	[43]	34	[63]	50	[3]	2	[23]	18	
	[44]	35	[64]	51	[4]	3	[24]	19	
	[45]	36	[65]	52	[5]	4	[25]	20	
	[46]	37	[66]	53	[6]	5	[26]	21	
	[47]	38	[67]	54	[7]	6	[27]	22	
	[48]	39	[68]	55	[8]	7	[28]	23	
	[49]	C2	[69]	C2	[9]	C1	[29]	C1	
	[50]	40	[70]	56	[10]	8	[30]	24	
	[51]	41	[71]	57	[11]	9	[31]	25	
	[52]	42	[72]	58	[12]	10	[32]	26	
	[53]	43	[73]	59	[13]	11	[33]	27	
	[54]	44	[74]	60	[14]	12	[34]	28	
	[55]	45	[75]	61	[15]	13	[35]	29	
	[56]	46	[76]	62	[16]	14	[36]	30	
	[57]	47	[77]	63	[17]	15	[37]	31	
	[58]	C2	[78]	C2	[18]	C1	[38]	C1	
	[59]	N.C.	[79]	N.C.	[19]	N.C.	[39]	N.C.	
	[60]	N.C.	[80]	N.C.	[20]	N.C.	[40]	N.C.	

Applicable connectors

- 120mm (4.73in.) space is required in front of the module. Be sure to consider this space in installation location.
- Use a shield cable with class D grounding.

Manufacturers	Fujitsu Takamizawa	Solder type	Socket: FCN-361J040-AU, Cover: FCN-360C040-E
		Crimp type	Housing: FCN-363J040, Contact: FCN-363J-AU
		Crimp type (flat cable)	FCN-367J040-AU/F
AMP		Solder type	1473381-1

(14) EH-YT8

Specification	EH-YT8	
Output specification	Transistor output (sink type)	
Number of outputs	8	
Rated load voltage	12/24V DC (+10%, -15%)	
Minimum switching current	1mA	
Leak current	0.1mA	
Maximum load current	1 circuit	0.5A (0.3A MFG No.02F** or before) *1
	1 common	
Output response time	OFF→ON	0.3ms maximum
	ON→OFF	1ms maximum
Insulation system	Photo-coupler insulation	
Output display	Green LED	
External connection	Removable type screw terminal block (M3)	
Number of outputs / common	8	
Surge removal circuit	Diode	
Fuse*2	4A / 1 common	
External power supply (for supplying power to S-terminal)	12/24V DC (+10%, -15%) (30mA at the maximum)	
Internal current consumption	30 mA maximum	
Short-circuit protection function	None	

*1 MFG No. indicates production month. 02F** means June 2002.

*2 The fuse is not replaced by users. Please contact your local supplier to repair.

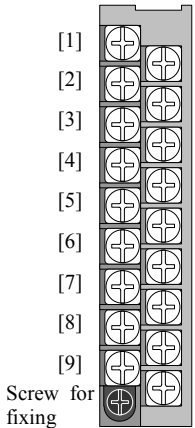
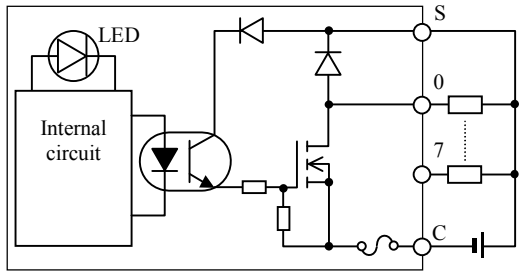
Terminal configuration	No.	Signal name	Diagram of Internal circuit
	[1]	0	
	[2]	1	
	[3]	2	
	[4]	3	
	[5]	4	
	[6]	5	
	[7]	6	
	[8]	7	
	[9]	C	
	[10]	N.C.	
	[11]	N.C.	
	[12]	N.C.	
	[13]	N.C.	
	[14]	N.C.	
	[15]	N.C.	
	[16]	N.C.	
	[17]	N.C.	
	[18]	S	

(15) EH-YT16

Specification	EH-YT16	
Output specification	Transistor output (sink type)	
Number of outputs	16	
Rated load voltage	12/24V DC (+10%, -15%)	
Minimum switching current	1mA	
Leak current	0.1mA	
Maximum load current	1 circuit	0.5A(0.3A MFG No.02F** or before)* ¹
	1 common	4A
Output response time	OFF→ON	0.3ms maximum
	ON→OFF	1ms maximum
Insulation system	Photo-coupler insulation	
Output display	Green LED	
External connection	Removable type screw terminal block (M3)	
Number of outputs / common	16	
Surge removal circuit	Diode	
Fuse * ²	8A / 1 common	
External connection (for supplying power to S-terminal)	12/24V DC (+10%, -15%) (30mA at the maximum)	
Internal current consumption	50 mA maximum	
Short-circuit protection function	None	

*1 MFG No. indicates production month. 02F** means June 2002.

*2 The fuse is not replaced by users. Please contact your local supplier to repair.

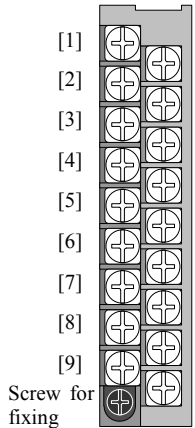
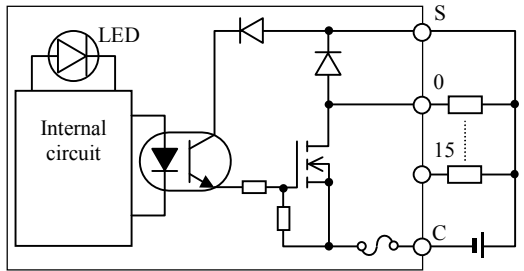
Terminal block	No.	Signal name	Diagram of Internal circuit
	[1]	0	
	[2]	1	
	[3]	2	
	[4]	3	
	[5]	4	
	[6]	5	
	[7]	6	
	[8]	7	
	[9]	C	
	[10]	8	
	[11]	9	
	[12]	10	
	[13]	11	
	[14]	12	
	[15]	13	
	[16]	14	
	[17]	15	
	[18]	S	

(16) EH-YTP8

Specification	EH-YTP8	
Output specification	Transistor output (source type)	
Number of outputs	8	
Rated load voltage	12/24V DC (+10%, -15%)	
Minimum switching current	1mA	
Leak current	0.1mA	
Maximum load current	1 circuit	0.5A(0.3A MFG No.02F** or before) * ¹
	1 common	2.4A
Output response time	OFF→ON	0.3ms maximum
	ON→OFF	1ms maximum
Insulation system	Photo-coupler insulation	
Output display	Green LED	
External connection	Removal type screw terminal block (M3)	
Number of outputs / common	8	
Surge removal circuit	Diode	
Fuse * ²	4A / 1 common	
External connection (for supplying power to S-terminal)	12/24V DC (+10%, -15%) (30mA at the maximum)	
Internal current consumption	30 mA maximum	
Short-circuit protection function	None	

*1 MFG No. indicates production month. 02F** means June 2002.

*2 The fuse is not replaced by users. Please contact your local supplier to repair.

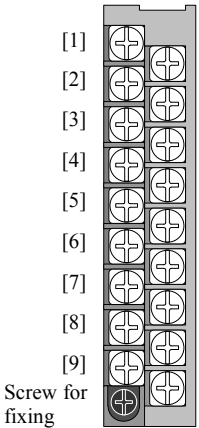
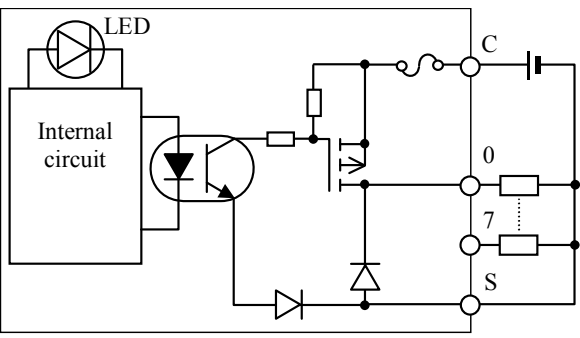
Terminal configuration	No.	Signal name	Diagram of Internal circuit
	[1]	0	
	[2]	1	
	[3]	2	
	[4]	3	
	[5]	4	
	[6]	5	
	[7]	6	
	[8]	7	
	[9]	C	
	[10]	N.C.	
	[11]	N.C.	
	[12]	N.C.	
	[13]	N.C.	
	[14]	N.C.	
	[15]	N.C.	
	[16]	N.C.	
	[17]	N.C.	
	[18]	S	

(17) EH-YTP16

Specification	EH-YTP16	
Output specification	Transistor output (source type)	
Number of outputs	16	
Rated load voltage	12/24V DC (+10%, -15%)	
Minimum switching current	1mA	
Leak current	0.1mA	
Maximum load current	1 circuit	0.5A (0.3A MFG No.02F** or before * ¹)
	1 common	4A
Output response time	OFF→ON	0.3ms maximum
	ON→OFF	1ms maximum
Insulation system	Photo-coupler insulation	
Output display	Green LED	
External connection	Removable type screw terminal block (M3)	
Number of outputs / common	16	
Surge removal circuit	Diode	
Fuse * ²	8A / 1 common	
External connection (for supplying power to S-terminal)	12/24V DC (+10%, -15%) (30mA at the maximum)	
Internal current consumption	50 mA maximum	
Short-circuit protection function	None	

*1 MFG No. indicates production month. 02F** means June 2002.

*2 The fuse is not replaced by users. Please contact your local supplier to repair.

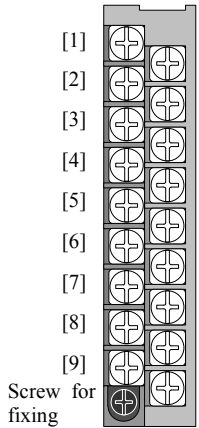
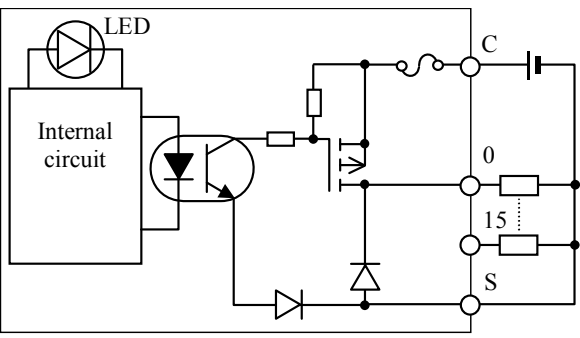
Terminal configuration	No.	Signal name	Diagram of Internal circuit
	[1]	0	
	[2]	1	
	[3]	2	
	[4]	3	
	[5]	4	
	[6]	5	
	[7]	6	
	[8]	7	
	[9]	C	
	[10]	8	
	[11]	9	
	[12]	10	
	[13]	11	
	[14]	12	
	[15]	13	
	[16]	14	
	[17]	15	
	[18]	S	

(18) EH-YTP16S

Specification	EH-YTP16S
Output specification	Transistor output (source type)
Number of outputs	16
Raged load voltage	12/24V DC (+10%, -15%)
Minimum switching current	1mA
Leak current	0.1mA
Maximum load current	1 circuit
	1 common
Output response time	0.3ms maximum
	1ms maximum
Insulation system	Photo-coupler insulation
Output display	Green LED
External connection	Removable type screw terminal block (M3)
Number of outputs / common	16
Surge removal circuit	Built-in
Fuse	None
External connection (for supplying power to S-terminal)	12/24V DC (+10%, -15%) (30mA at the maximum)
Internal current consumption	50 mA maximum
Short-circuit protection function	Available

Terminal configuration	No.	Signal name	Diagram of Internal circuit
	[1]	0	
	[2]	1	
	[3]	2	
	[4]	3	
	[5]	4	
	[6]	5	
	[7]	6	
	[8]	7	
	[9]	C	
	[10]	8	
	[11]	9	
	[12]	10	
	[13]	11	
	[14]	12	
	[15]	13	
	[16]	14	
	[17]	15	
	[18]	S	

(19) EH-YR8B

Specification	EH-YR8B	
Output specification	Relay output	
Number of outputs	8	
Rated load voltage	100/240V AC , 24V DC	
Minimum switching current	1mA (5V DC), except after a great current switching	
Leak current	None	
Maximum load current	1 circuit	2A
	1 common	2A
Output response time	OFF→ON	10ms maximum
	ON→OFF	10ms maximum
Insulation system	Relay insulation	
Output display	Green LED	
External connection	Removable type screw terminal block (M3)	
Number of outputs / common	1 (each output separated)	
Surge removal circuit	Varistor (Varistor voltage 423 to 517V)	
Fuse	None	
External power supply	Not necessary	
Internal current consumption (5V DC)	220 mA maximum	

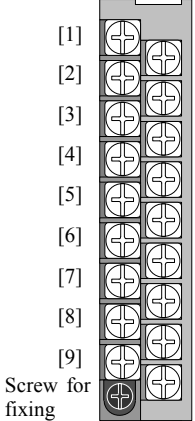
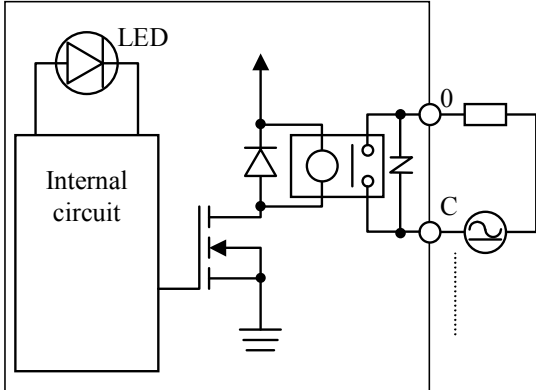
Terminal configuration	No.	Signal name	Diagram of Internal circuit
	[1]	0	
	[2]	1	
	[3]	2	
	[4]	3	
	[5]	4	
	[6]	5	
	[7]	6	
	[8]	7	
	[9]	N.C.	
	[10]	C0	
	[11]	C1	
	[12]	C2	
	[13]	C3	
	[14]	C4	
	[15]	C5	
	[16]	C6	
	[17]	C7	
	[18]	N.C.	

(20) EH-YR12

Specification	EH-YR12	
Output specification	Relay output	
Number of outputs	12	
Rated load voltage	100/240V AC, 24V DC	
Minimum switching current	1mA (5V DC), except a great current switching	
Leak current	None	
Maximum load current	1 circuit	2A
	1 common	5A
Output response time	OFF→ON	10ms maximum
	ON→OFF	10ms maximum
Insulation system	Photo-coupler insulation	
Output display	Green LED	
External connection	Removable type screw terminal block (M3)	
Number of outputs / common	12 (1 common, 2 terminals)	
Surge removal circuit	None	
Fuse	None	
External power supply	24V DC (+10%, -15%) (70mA at the maximum)	
Internal current consumption (5V DC)	40 mA maximum	

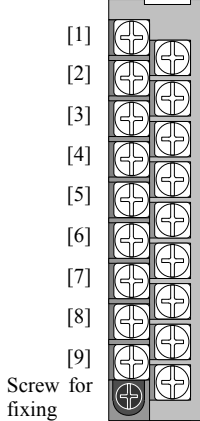
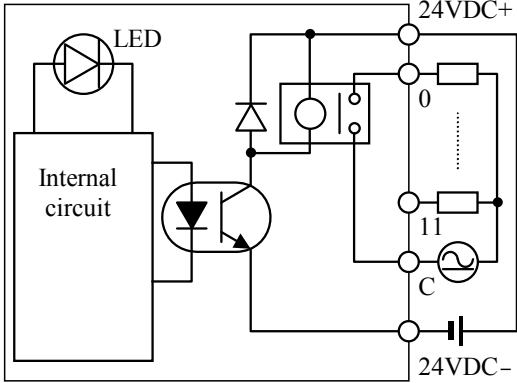
Terminal configuration	No.	Signal name	Diagram of Internal circuit
	[1]	24V DC+	
	[2]	N.C.	
	[3]	0	
	[4]	1	
	[5]	2	
	[6]	3	
	[7]	4	
	[8]	5	
	[9]	C	
	[10]	24V DC-	
	[11]	N.C.	
	[12]	6	
	[13]	7	
	[14]	8	
	[15]	9	
	[16]	10	
	[17]	11	
	[18]	C	

(21) EH-YR16

Specification	EH-YR16
Output specification	Relay output
Number of outputs	16
Rated load voltage	100/240V AC, 24V DC
Minimum switching current	1mA (5V DC), except after a great current switching
Leak current	None
Maximum load current	2A
	8A (Ambient temperature 40°C), see the following derating table
Output response time	10ms maximum
	10ms maximum
Insulation system	Relay insulation
Output display	Green LED
External connection	Removal type screw terminal block (M3)
Number of output points / commons	16 (1 common, 2 terminals)
Surge removal circuit	None
Fuse	None
External power supply	Not used
Internal current consumption (5V DC)	430 mA maximum

Terminal configuration	No.	Signal name	Diagram of Internal circuit						
	[1]	0	<p>EH-YR16 Derating table</p> <table border="1"> <caption>EH-YR16 Derating table</caption> <thead> <tr> <th>Ambient temperature (°C)</th> <th>Maximum common current (A)</th> </tr> </thead> <tbody> <tr> <td>20 - 40</td> <td>8</td> </tr> <tr> <td>40 - 55</td> <td>7</td> </tr> </tbody> </table>	Ambient temperature (°C)	Maximum common current (A)	20 - 40	8	40 - 55	7
	Ambient temperature (°C)	Maximum common current (A)							
	20 - 40	8							
	40 - 55	7							
	[2]	1							
	[3]	2							
	[4]	3							
	[5]	4							
	[6]	5							
	[7]	6							
	[8]	7							
	[9]	C							
	[10]	8							
	[11]	9							
	[12]	10							
	[13]	11							
	[14]	12							
	[15]	13							
[16]	14								
[17]	15								
[18]	C								

(22) EH-YR16D

Specification	EH-YR16D
Output specification	Relay output
Number of outputs	16
Rated load voltage	100/240V AC, 24V DC
Minimum switching current	1mA (5V DC), except after a great current switching
Leak current	None
Maximum load current	2A
	4A (Ambient temperature 40°C), see the following derating table
Output response time	10ms maximum
	10ms maximum
Insulation system	Relay insulation
Output display	Green LED
External connection	Removal type screw terminal block (M3)
Number of output points / commons	8 (2 common, 2 terminals)
Surge removal circuit	None
Fuse	None
External power supply	Not used
Internal current consumption (5V DC)	430 mA maximum

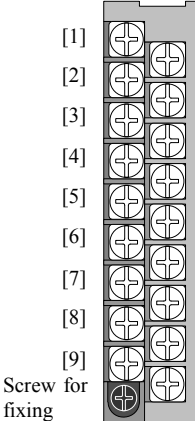
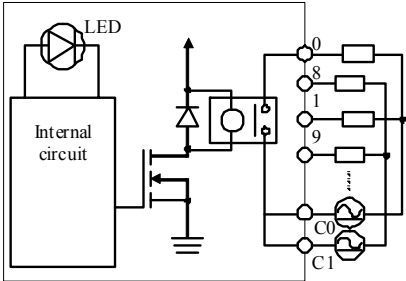
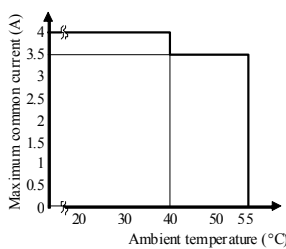
Terminal configuration	No.	Signal name	Diagram of Internal circuit
	[1]	0	 <p>EH-YR16D Derating table</p> 
	[2]	1	
	[3]	2	
	[4]	3	
	[5]	4	
	[6]	5	
	[7]	6	
	[8]	7	
	[9]	C0	
	[10]	8	
	[11]	9	
	[12]	10	
	[13]	11	
	[14]	12	
	[15]	13	
	[16]	14	
	[17]	15	
	[18]	C1	

(23) EH-YS4

Specification	EH-YS4	
Output specification	Triac output	
Number of outputs	4	
Rated load voltage	100/240V AC (85 to 250V AC)	
Minimum switching current	100mA	
Leak current	5mA maximum	
Maximum load current	1 circuit	0.5A
	1 common	2A
Output response time	OFF→ON	1ms maximum
	ON→OFF	1ms + 1/2 cycle maximum
Insulation system	Photo-coupler triac insulation	
Output display	Green LED	
External connection	Removable type screw terminal block (M3)	
Number of outputs / common	4	
Surge removal circuit	Varistor	
Fuse *1	4A	
Internal current consumption	70 mA maximum	

*1 The fuse is not replaced by users. Please contact your local supplier to repair.

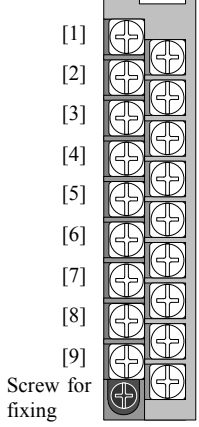
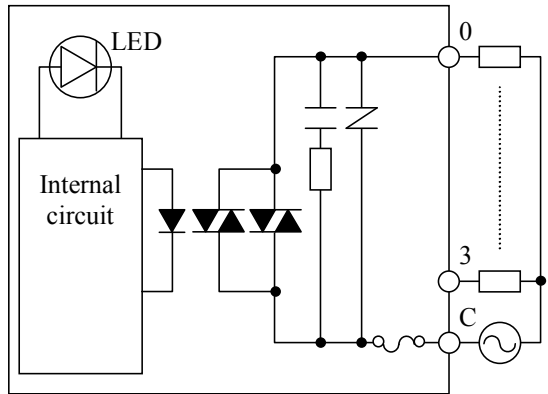
Terminal configuration	No.	Signal name	Diagram of Internal circuit
	[1]	0	
	[2]	N.C.	
	[3]	1	
	[4]	N.C.	
	[5]	2	
	[6]	N.C.	
	[7]	3	
	[8]	N.C.	
	[9]	C	
	[10]	N.C.	
	[11]	N.C.	
	[12]	N.C.	
	[13]	N.C.	
	[14]	N.C.	
	[15]	N.C.	
	[16]	N.C.	
	[17]	N.C.	
	[18]	N.C.	

(24) EH-YS16

Specification	EH-YS16	
Output specification	Triac output	
Number of outputs	16	
Rated load voltage	100/240V AC (85 to 250V AC)	
Minimum switching current	10mA	
Leak current	2mA	
Maximum load current	1 circuit	0.3A
	1 common	4A (Ambient temperature 45°C), see the following derating table
Output response time	OFF→ON	1ms maximum
	ON→OFF	1ms + 1/2 cycle maximum
Insulation system	Photo-coupler triac insulation	
Output display	Green LED	
External connection	Removable type screw terminal block (M3)	
Number of output points / commons	16 (1 common, 2 terminals)	
Surge removal circuit	Varistor	
Fuse *1	6.3A (Be sure to install external fuse)	
Internal current consumption	250 mA maximum	

*1 The fuse is not replaced by users. Please contact your local supplier to repair.

Terminal configuration	No.	Signal name	Diagram of Internal output
	[1]	0	
	[2]	1	
	[3]	2	
	[4]	3	
	[5]	4	
	[6]	5	
	[7]	6	
	[8]	7	
	[9]	C	
	[10]	8	
	[11]	9	
	[12]	10	
	[13]	11	
	[14]	12	
	[15]	13	
	[16]	14	
	[17]	15	
	[18]	C	

Derating table

Ambient temperature (°C)	Maximum common current (A)
20	4
45	4
55	2

(25) EH-YT32

Specification	EH-YT32
Output specification	Transistor output (sink type)
Number of outputs	32
Rated load voltage	12/24V DC (+10%, -15%)
Minimum switching current	1mA
Leak current	0.1mA
Maximum load current	1 circuit
	1 common
	0.2A
	4A * ¹
Output response time	OFF→ON
	ON→OFF
	0.3ms maximum
	1ms maximum
Insulation system	Photo-coupler insulation
Output display	Green LED
External connection	Connector
Number of outputs / common	32 (1 common, 4 terminals)
Surge removal circuit	Diode
Fuse * ²	10A / 1 common
External connection (for supplying power to S-terminal)	12/24V DC (+10%, -15%) (30mA at the maximum)
Internal current consumption (5V DC)	90 mA maximum
Short-circuit protection function	Available

*1 Total current of 4 common pins. The maximum current for single common terminal is 3A.

*2 The fuse is not replaced by users. Please contact your local supplier to repair.

Terminal configuration	No.	Signal name	No.	Signal name	Diagram of Internal circuit
	[1]	0	[21]	16	
	[2]	1	[22]	17	
	[3]	2	[23]	18	
	[4]	3	[24]	19	
	[5]	4	[25]	20	
	[6]	5	[26]	21	
	[7]	6	[27]	22	
	[8]	7	[28]	23	
	[9]	C	[29]	C	
	[10]	S	[30]	S	
	[11]	8	[31]	24	
	[12]	9	[32]	25	
	[13]	10	[33]	26	
	[14]	11	[34]	27	
	[15]	12	[35]	28	
	[16]	13	[36]	39	
	[17]	14	[37]	30	
	[18]	15	[38]	31	
	[19]	C	[39]	C	
	[20]	S	[40]	S	

Applicable connectors

- 120mm (4.73in.) space is required in front of the module. Be sure to consider this space in installation location.
- Use a shield cable with class D grounding.

Manufacturers	Fujitsu Takamizawa	Solder type	Socket: FCN-361J040-AU, Cover: FCN-360C040-E
		Crimp type	Housing: FCN-363J040, Contact: FCN-363J-AU
		Crimp type (flat cable)	FCN-367J040-AU/F
	AMP	Solder type	1473381-1

(26) EH-YTP32

Specification	EH-YTP32	
Output specification	Transistor output (source type)	
Number of outputs	32	
Rated load voltage	12/24V DC (+10%, -15%)	
Minimum switching current	1mA	
Leak current	0.1mA	
Maximum load current	1 circuit	0.2A
	1 common	4A * ¹
Output response time	OFF→ON	0.3ms maximum
	ON→OFF	1ms maximum
Insulation system	Photo-coupler insulation	
Output display	Green LED	
External connection	Connector	
Number of outputs / common	32 (1 common, 4 terminals)	
Surge removal circuit	Diode	
Fuse * ²	10A / 1 common	
External power supply (for supplying power to S-terminal)	12/24V DC (+10%, -15%) (30mA at the maximum)	
Internal current consumption (5V DC)	90 mA maximum	
Short-circuit protection function	Available	

*1 Total current of 4 common pins. The maximum current for single common terminal is 3A.

*2 The fuse is not replaced by users. Please contact your local supplier to repair.

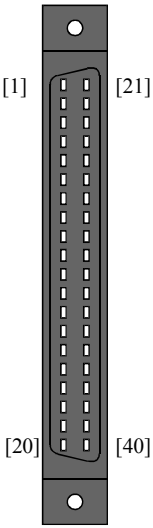
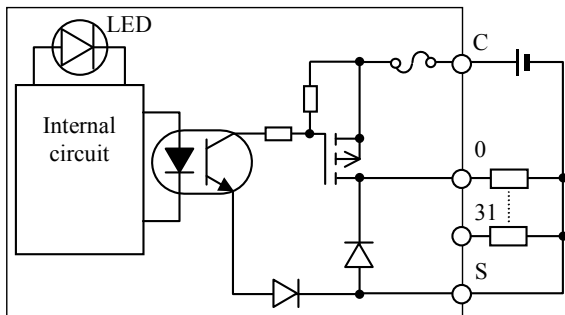
Terminal configuration	No.	Signal name	No.	Signal name	Diagram of Internal circuit
	[1]	0	[21]	16	
	[2]	1	[22]	17	
	[3]	2	[23]	18	
	[4]	3	[24]	19	
	[5]	4	[25]	20	
	[6]	5	[26]	21	
	[7]	6	[27]	22	
	[8]	7	[28]	23	
	[9]	C	[29]	C	
	[10]	S	[30]	S	
	[11]	8	[31]	24	
	[12]	9	[32]	25	
	[13]	10	[33]	26	
	[14]	11	[34]	27	
	[15]	12	[35]	28	
	[16]	13	[36]	29	
	[17]	14	[37]	30	
	[18]	15	[38]	31	
	[19]	C	[39]	C	
	[20]	S	[40]	S	
Applicable connectors - 120mm (4.73in.) space is required in front of the module. Be sure to consider this space in installation location. - Use a shield cable with class D grounding.					
Manufacturers	Fujitsu Takamizawa	Solder type	Socket: FCN-361J040-AU, Cover: FCN-360C040-E		
		Crimp type	Housing: FCN-363J040, Contact: FCN-363J-AU		
		Crimp type (flat cable)	FCN-367J040-AU/F		
	AMP	Solder type	1473381-1		

(27) EH-YT32E

Specification	EH-YT32E
Output specification	Transistor output (sink type)
Number of outputs	32
Rated load voltage	12/24V DC (+10%, -15%)
Minimum switching current	1mA
Leak current	0.1mA
Maximum load current	1 circuit
	1 common
Output response time	OFF→ON
	ON→OFF
Insulation system	Photo-coupler insulation
Output display	Green LED
External connection	Spring type terminal block
Number of outputs / common	8 (4 commons, 4 terminals)
Surge removal circuit	Diode
Fuse*1	10A / 1 common
External power supply (for supplying power to S-terminal)	12/24V DC (+10%, -15%) (30mA at the maximum)
Internal current consumption (5V DC)	90 mA maximum
Short-circuit protection function	Available

*1 The fuse is not replaced by users. Please contact your local supplier to repair.

Terminal configuration	No.	Signal name	No.	Signal name	Diagram of Internal circuit
	[1]	0	[21]	16	
	[2]	1	[22]	17	
	[3]	2	[23]	18	
	[4]	3	[24]	19	
	[5]	4	[25]	20	
	[6]	5	[26]	21	
	[7]	6	[27]	22	
	[8]	7	[28]	23	
	[9]	C1	[29]	C3	
	[10]	S1	[30]	S3	
	[11]	8	[31]	24	
	[12]	9	[32]	25	
	[13]	10	[33]	26	
	[14]	11	[34]	27	
	[15]	12	[35]	28	
	[16]	13	[36]	29	
	[17]	14	[37]	30	
	[18]	15	[38]	31	
	[19]	C2	[39]	C4	
	[20]	S2	[40]	S4	
Applicable connector		Applicable cable			
Manufacturer: Weidmuller Type: B2L3.5/20AUOR Product No.: 175736		0.5mm ² – 1.0mm ² (shared at a twisted pair cable and a single core cable.) AWG 28 - 18 A crimp terminal cannot be used.			

(28) EH-YTP32E

Specification	EH-YTP32E	
Output specification	Transistor output (source type)	
Number of outputs	32	
Rated load voltage	12/24V DC (+10%, -15%)	
Minimum switching current	1mA	
Leak current	0.1mA	
Maximum load current	1 circuit	0.2A
	1 common	1A
Output response time	OFF→ON	0.3ms maximum
	ON→OFF	1ms maximum
Insulation system	Photo-coupler insulation	
Output display	Green LED	
External connection	Spring type terminal block	
Number of outputs / common	8 (4 commons, 4 terminals)	
Surge removal circuit	Diode	
Fuse *1	10A / 1 common	
External power supply (for supplying power to S-terminal)	12/24V DC (+10%, -15%) (30mA at the maximum)	
Internal current consumption (5V DC)	90 mA maximum	
Short-circuit protection function	Available	

*1 The fuse is not replaced by users. Please contact your local supplier to repair.

Terminal configuration	No.	Signal name	No.	Signal name	Diagram of Internal circuit
	[1]	0	[21]	16	
	[2]	1	[22]	17	
	[3]	2	[23]	18	
	[4]	3	[24]	19	
	[5]	4	[25]	20	
	[6]	5	[26]	21	
	[7]	6	[27]	22	
	[8]	7	[28]	23	
	[9]	C1	[29]	C3	
	[10]	S1	[30]	S3	
	[11]	8	[31]	24	
	[12]	9	[32]	25	
	[13]	10	[33]	26	
	[14]	11	[34]	27	
	[15]	12	[35]	28	
	[16]	13	[36]	29	
	[17]	14	[37]	30	
	[18]	15	[38]	31	
	[19]	C2	[39]	C4	
	[20]	S2	[40]	S4	
Applicable connectors			Applicable cable		
Manufacturer: Weidmuller Type: B2L3.5/20AUOR Product No.: 175736			0.5mm ² – 1.0mm ² (shared at a twisted pair cable and a single core cable. AWG 28 - 18 A crimp terminal cannot be used.		

(29) EH-YT32H

Item		POM-TM, POH-TM (for replacing)	EH-YT32H (This product)
Series		EM/EM-II, H-200/250/252	EH-150
Output specification		Transistor output (sink type)	
Number of outputs		32	
Rated load voltage		5/12/24V DC (5 to 27V DC)	
Minimum switching current		1 mA	
Leak current		0.05 mA maximum	
Maximum output saturation voltage		1 V maximum	
Maximum load current	1 point	0.1 A	
	1 common	0.8 A	
Output response time	OFF→ON	1 ms maximum	
	ON→OFF	1 ms maximum	
Insulation method		Photo-coupler insulation	
Output display		LED (red)	LED (green)
External connection		Connector (50 pins)	
Number outputs / common		8 (4 commons, 4 terminals)	
Surge removal circuit		Diode (Connecting case of the S terminal)	
Fuse * ¹		1.5 A / 1 common	2 A / 1 common
External power supply * ² (For supplying power to the S terminal)		5 to 27 V DC (maximum 100 mA)	
Internal current consumption (5 V DC)		70 mA maximum	90 mA maximum
Short-circuit protection		None	

*¹ The fuse is not replaced by users. Please contact your local supplier to repair.

*² It is necessary to supply 12/24 V DC to the S terminals.

Specification of external wiring connector				Wire
Product name	Manufacturer	Product No.	Connection method	
Plug connector	Hirose Electric Co., Ltd.	DX30-50P	Untie crimping	AWG#30
		DX30A-50P		AWG#28
		DX31-50P	Crimping	AWG#30
		DX31A-50P		AWG#28
		DX40-50P	Soldering	—
Die cast cover		DX-50-CV1	—	—

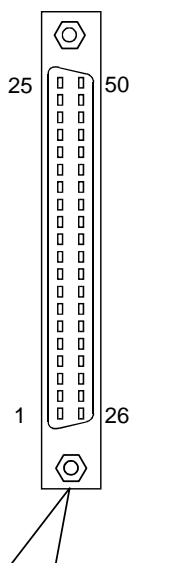
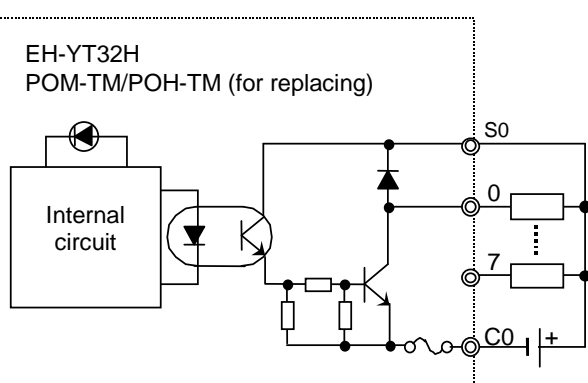
Terminal configuration	No.	Signal name	No.	Signal name	Diagram of Internal circuit
 <p>Please note it in the direction of the connector*1</p>	[25]	NC	[50]	NC	 <p>EH-YT32H POM-TM/POH-TM (for replacing)</p>
	[24]	NC	[49]	NC	
	[23]	NC	[48]	NC	
	[22]	NC	[47]	NC	
	[21]	15	[46]	31	
	[20]	14	[45]	30	
	[19]	13	[44]	29	
	[18]	12	[43]	28	
	[17]	11	[42]	27	
	[16]	10	[41]	26	
	[15]	9	[40]	25	
	[14]	8	[39]	24	
	[13]	S1	[38]	S3	
	[12]	C1	[37]	C3	
	[11]	NC	[36]	NC	
	[10]	7	[35]	23	
	[9]	6	[34]	22	
	[8]	5	[33]	21	
	[7]	4	[32]	20	
	[6]	3	[31]	19	
	[5]	2	[30]	18	
	[4]	1	[29]	17	
	[3]	0	[28]	16	
	[2]	S0	[27]	S2	
	[1]	C0	[26]	C2	

*1 The mounted direction of the connector for EH-YT32H is 180 degrees opposite with EM/H-200 series. Plug cable connector with rotating 180 degrees. (It is mechanically not possible to plug in wrong direction.)

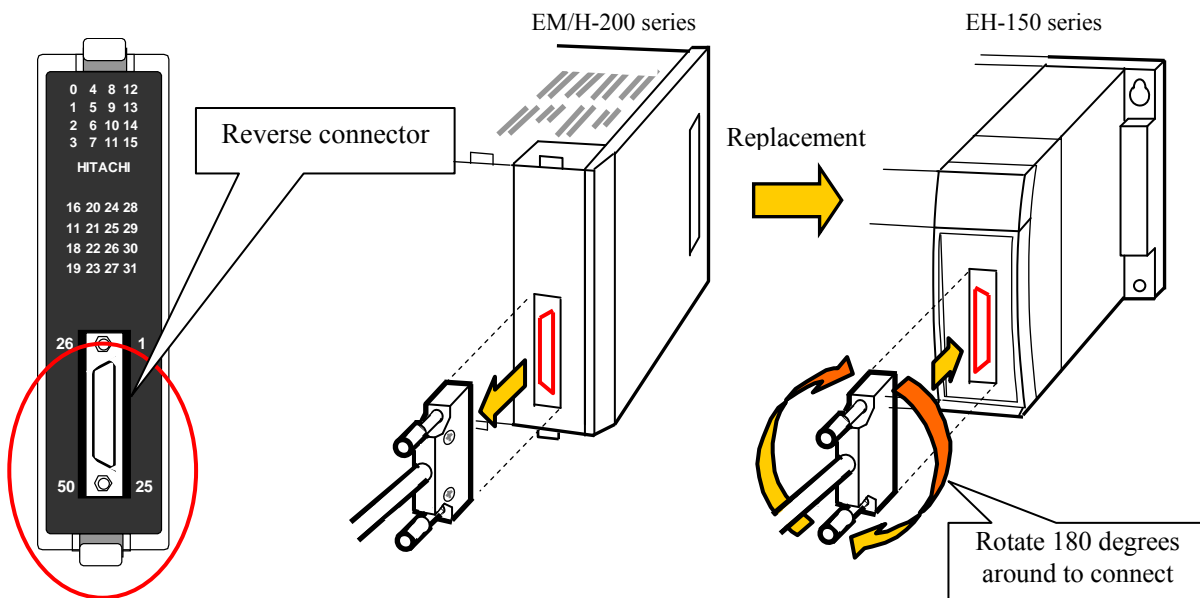

(30) EH-YT64

Specification	EH-YT64
Output specification	Transistor output (sink type)
Number of outputs	64
Rated load voltage	12/24V DC (+10%, -15%)
Minimum switching current	1mA
Leak current	0.1mA
Maximum load current	1 circuit
	1 common
Output response time	0.3ms maximum
	ON→OFF
	1ms maximum
Insulation system	Photo-coupler insulation
Output display	Green LED
External connection	Connector
Number of outputs / common	32 (2 commons, 8 terminals)
Surge removal circuit	Diode
Fuse *1	5A / 1 common
External power supply (for supplying power to S-terminal)	12/24V DC (+10%, -15%) (100mA at the maximum)
Internal current consumption (5V DC)	120 mA maximum
Short-circuit protection function	Available

*1 The fuse is not replaced by users. Please contact your local supplier to repair.

Terminal configuration	No.	Signal name	No.	Signal name	No.	Signal name	No.	Signal name	Diagram of Internal circuit
	[41]	32	[61]	48	[1]	0	[21]	16	
	[42]	33	[62]	49	[2]	1	[22]	17	
	[43]	34	[63]	50	[3]	2	[23]	18	
	[44]	35	[64]	51	[4]	3	[24]	19	
	[45]	36	[65]	52	[5]	4	[25]	20	
	[46]	37	[66]	53	[6]	5	[26]	21	
	[47]	38	[67]	54	[7]	6	[27]	22	
	[48]	39	[68]	55	[8]	7	[28]	23	
	[49]	C2	[69]	C2	[9]	C1	[29]	C1	
	[50]	S2	[70]	S2	[10]	S1	[30]	S1	
	[51]	40	[71]	56	[11]	8	[31]	24	
	[52]	41	[72]	57	[12]	9	[32]	25	
	[53]	42	[73]	58	[13]	10	[33]	26	
	[54]	43	[74]	59	[14]	11	[34]	27	
	[55]	44	[75]	60	[15]	12	[35]	28	
	[56]	45	[76]	61	[16]	13	[36]	29	
	[57]	46	[77]	62	[17]	14	[37]	30	
	[58]	47	[78]	63	[18]	15	[38]	31	
	[59]	C2	[79]	C2	[19]	C1	[39]	C1	
	[60]	S2	[80]	S2	[20]	S1	[40]	S1	

Applicable connectors
 - 120mm (4.73in.) space is required in front of the module. Be sure to consider this space in installation location.
 - Use a shield cable with class D grounding.

Manufacturers	Fujitsu Takamizawa	Solder type	Socket: FCN-361J040-AU, Cover: FCN-360C040-E
		Crimp type	Housing: FCN-363J040, Contact: FCN-363J-AU
		Crimp type (flat cable)	FCN-367J040-AU/F
AMP	Solder type	1473381-1	

(31) EH-YTP64

Specification	EH-YTP64	
Output specification	Transistor output (source type)	
Number of output points	64	
Rated load voltage	12/24V DC (+10%, -15%)	
Minimum switching current	1mA	
Leak current	0.1mA	
Maximum load current	1 circuit	0.1A
	1 common	3.2A
Output response time	OFF→ON	0.3ms maximum
	ON→OFF	1ms maximum
Insulation system	Photo-coupler insulation	
Output display	Green LED	
External connection	Connector	
Number of output points / commons	32 (2 commons, 8 terminals)	
Surge removal circuit	Diode	
Fuse *1	5A / 1 common	
External power supply (for supplying power to S-terminal)	12/24V DC (+10%, -15%) (100mA at the maximum)	
Internal current consumption (5V DC)	120 mA maximum	
Short-circuit protection function	Available	

*1 The fuse is not replaced by users. Please contact your local supplier to repair.



Terminal configuration	No.	Signal name	No.	Signal name	No.	Signal name	No.	Signal name	Diagram of Internal circuit
	[41]	32	[61]	48	[1]	0	[21]	16	
	[42]	33	[62]	49	[2]	1	[22]	17	
	[43]	34	[63]	50	[3]	2	[23]	18	
	[44]	35	[64]	51	[4]	3	[24]	19	
	[45]	36	[65]	52	[5]	4	[25]	20	
	[46]	37	[66]	53	[6]	5	[26]	21	
	[47]	38	[67]	54	[7]	6	[27]	22	
	[48]	39	[68]	55	[8]	7	[28]	23	
	[49]	C2	[69]	C2	[9]	C1	[29]	C1	
	[50]	S2	[70]	S2	[10]	S1	[30]	S1	
	[51]	40	[71]	56	[11]	8	[31]	24	
	[52]	41	[72]	57	[12]	9	[32]	25	
	[53]	42	[73]	58	[13]	10	[33]	26	
	[54]	43	[74]	59	[14]	11	[34]	27	
	[55]	44	[75]	60	[15]	12	[35]	28	
	[56]	45	[76]	61	[16]	13	[36]	29	
	[57]	46	[77]	62	[17]	14	[37]	30	
	[58]	47	[78]	63	[18]	15	[38]	31	
	[59]	C2	[79]	C2	[19]	C1	[39]	C1	
	[60]	S2	[80]	S2	[20]	S1	[40]	S1	

Applicable connectors
- 120mm (4.73in.) space is required in front of the module. Be sure to consider this space in installation location.
- Use a shield cable with class D grounding.

Manufacturers	Fujitsu Takamizawa	Solder type	Socket: FCN-361J040-AU, Cover: FCN-360C040-E
		Crimp type	Housing: FCN-363J040, Contact: FCN-363J-AU
		Crimp type (flat cable)	FCN-367J040-AU/F
AMP	Solder type	1473381-1	

2.8 Analog I/O Modules

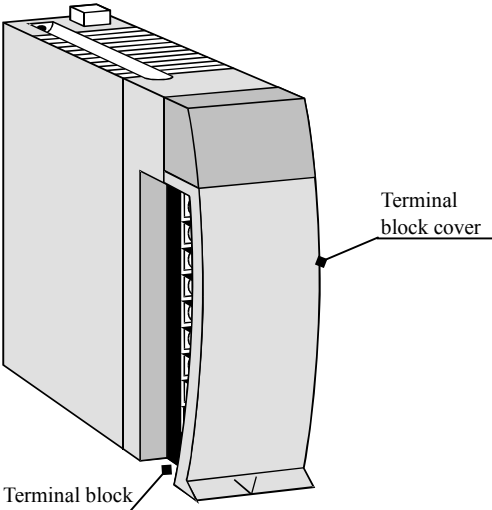
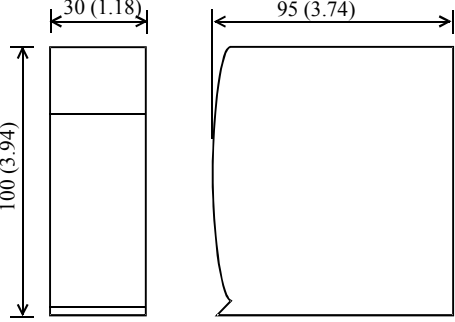
2.8.1 Standard analog modules

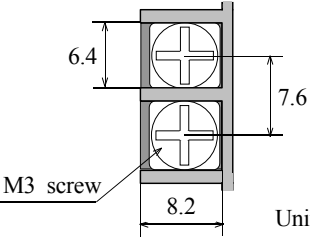
Module features	 <p>Terminal block cover</p> <p>Terminal block</p>		<p>Type (Weight)</p> <p>EH-AX44 (Approx. 0.18kg (0.41lb.))</p> <p>EH-AX8V, AX8H (Approx. 0.18kg (0.41lb.))</p> <p>EH-AX8I, AX8IO (Approx. 0.18kg (0.41lb.))</p> <p>EH-AY22 (Approx. 0.18kg (0.41lb.))</p> <p>EH-AY2H (Approx. 0.18kg (0.41lb.))</p> <p>EH-AY4V, AY4H (Approx. 0.18kg (0.41lb.))</p> <p>EH-AY4I (Approx. 0.18kg (0.41lb.))</p>	<p>Dimensions (mm (in.))</p> 
Item	Description			
Terminal block	<p>The terminal block is to connect I/O signals. It is removable type. The screw size is M3.</p> <p>Use a suitable sized crimping terminal for the screw. The terminal block supports 0.3 to 2mm² (AWG22 to 14). However, recommended cable is from 0.5 to 0.75mm² (AWG20 to 18). If 2 crimping terminals are connected to one terminal screw, use 0.5mm² (AWG20) cable.</p> <p>The recommended crimping terminal is indicated as below.</p>  <p>(Recommended)</p>  <p>Unit: mm (in.)</p> <p>Handle very carefully since cable could be detached when screw is loose.</p>		 <p>M3 screw</p> <p>Unit: in.</p>	
Terminal block cover	This is a covert for installing on the terminal block.			

(1) EH-AX44

Specification		EH-AX44
Current range		4 to 20mA
Voltage range		0 to 10V DC
Number of channels	Current	4 (Ch.0 to 3)
	Voltage	4 (Ch.4 to 7)
Resolution		12 bits
Conversion time		5ms maximum
Overall accuracy		± 1% maximum of full-scale
Input impedance	Current	Approx. 100 Ω
	Voltage	Approx. 100k Ω
Insulation system	Channel and Internal circuit	Photo-coupler insulation
	Between channels	No insulation
External connection		Removable type screw terminal block (M3)
External power supply		24V DC (+20%, -15%) Approx. 150mA (Approx. 400mA at power ON)
External wiring		2-core shield cable (20m (65.62ft.) maximum)
Internal current consumption		100mA maximum

Terminal configuration	No.	Signal name	Diagram of Internal circuit
	[1]	I0 +	
	[2]	I1 +	
	[3]	I2 +	
	[4]	I3 +	
	[5]	V4 +	
	[6]	V5 +	
	[7]	V6 +	
	[8]	V7 +	
	[9]	24 VDC +	
	[10]	I0 -	
	[11]	I1 -	
	[12]	I2 -	
	[13]	I3 -	
	[14]	V4 -	
	[15]	V5 -	
	[16]	V6 -	
	[17]	V7 -	
	[18]	24 VDC -	

Relation between analog and digital data

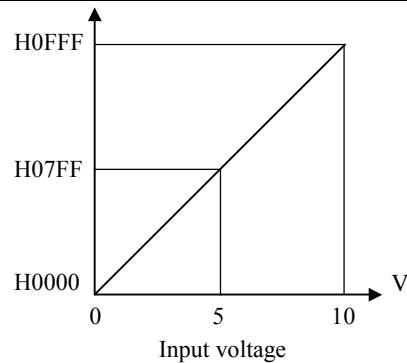
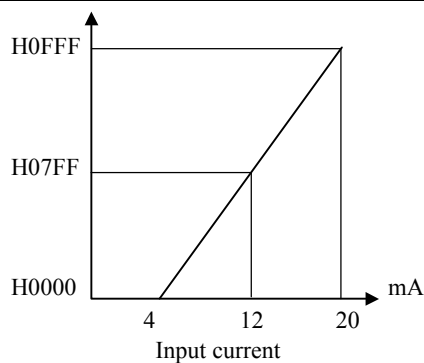

(2) EH-AX8V

Specification		EH-AX8V
Voltage range		0 to 10V DC
Number of channels		8
Resolution		12 bits
Conversion time		5ms maximum
Overall accuracy		± 1% maximum of full-scale
Input impedance		Approx. 100k Ω
Insulation system	Channel and Internal circuit	Photo-coupler insulation
	Between channels	No insulation
External connection		Removable type screw terminal block (M3)
External power supply		24V DC (+20%, -15%) Approx. 150mA (Approx. 400mA at power ON)
External wiring		2-core shield cable (20m (65.62ft.) maximum)
Internal current consumption		100mA maximum

Terminal configuration	No.	Signal name	Diagram of Internal circuit
	[1]	V0 +	
	[2]	V1 +	
	[3]	V2 +	
	[4]	V3 +	
	[5]	V4 +	
	[6]	V5 +	
	[7]	V6 +	
	[8]	V7 +	
	[9]	24 VDC +	
	[10]	V0 -	
	[11]	V1 -	
	[12]	V2 -	
	[13]	V3 -	
	[14]	V4 -	
	[15]	V5 -	
	[16]	V6 -	
	[17]	V7 -	
	[18]	24 VDC -	

Relation between analog and digital data

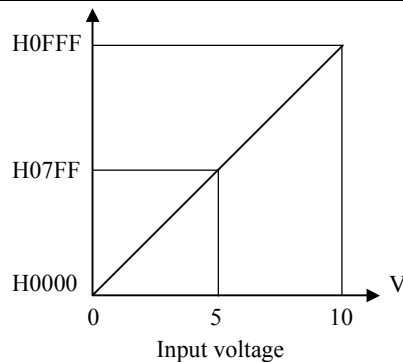

(3) EH-AX8H

Specification		EH-AX8H
Voltage range		-10 to +10V DC
Number of channels		8
Resolution		12 bits
Conversion time		5ms maximum
Overall accuracy		±1% maximum of full-scale
Input impedance		Approx. 100kΩ
Insulation system	Channel and Internal circuit	Photo-coupler insulation
	Between channels	No insulation
External connection		Removable type screw terminal block (M3)
External power supply		24V DC (+20%, -15%) Approx. 150mA (Approx. 400mA at power ON)
External wiring		2-core shield cable (20m (65.62ft.) maximum)
Internal current consumption		100mA maximum

Terminal configuration	No.	Signal name	Diagram of Internal circuit
	[1]	V0 +	
	[2]	V1 +	
	[3]	V2 +	
	[4]	V3 +	
	[5]	V4 +	
	[6]	V5 +	
	[7]	V6 +	
	[8]	V7 +	
	[9]	24 VDC +	
	[10]	V0 -	
	[11]	V1 -	
	[12]	V2 -	
	[13]	V3 -	
	[14]	V4 -	
	[15]	V5 -	
	[16]	V6 -	
	[17]	V7 -	
	[18]	24 VDC -	

Relation between analog and digital data

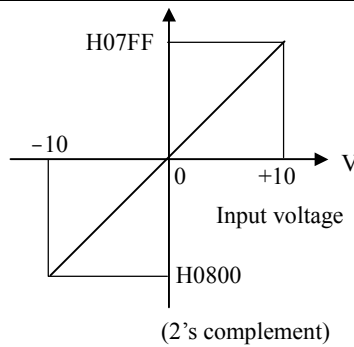

(4) EH-AX8I

Specification		EH-AX8I
Current range		4 to 20mA
Number of channels		8
Resolution		12 bits
Conversion time		5ms maximum
Overall accuracy		± 1% maximum of full-scale
Input impedance		Approx. 100 Ω
Insulation system	Channel and Internal circuit	Photo-coupler insulation
	Between channels	No insulation
External connection		Removable type screw terminal block (M3)
External power supply		24V DC (+20%, -15%) Approx. 150mA (Approx. 400mA at power ON)
External wiring		2-core shield cable (20m (65.62ft.) maximum)
Internal current consumption		100mA maximum

Terminal configuration	No.	Signal name	Diagram of Internal circuit
	[1]	I0 +	
	[2]	I1 +	
	[3]	I2 +	
	[4]	I3 +	
	[5]	I4 +	
	[6]	I5 +	
	[7]	I6 +	
	[8]	I7 +	
	[9]	24 VDC +	
	[10]	I0 -	
	[11]	I1 -	
	[12]	I2 -	
	[13]	I3 -	
	[14]	I4 -	
	[15]	I5 -	
	[16]	I6 -	
	[17]	I7 -	
	[18]	24 VDC -	

Relation between analog and digital data

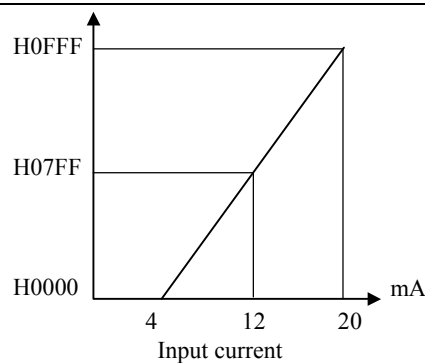

(5) EH-AX8IO

Specification		EH-AX8IO
Current range		0 to 22mA
Number of channels		8
Resolution		12 bits
Conversion time		5ms maximum
Overall accuracy		± 1% maximum of full-scale
Input impedance		Approx. 100 Ω
Insulation system	Channel and Internal circuit	Photo-coupler insulation
	Between channels	No insulation
External connection		Removable type screw terminal block (M3)
External power supply		24V DC (+20%, -15%) Approx. 150mA (Approx. 400mA at power ON)
External wiring		2-core shield cable (20m (65.62ft.) maximum)
Internal current consumption		100mA maximum

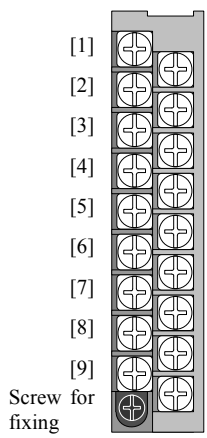
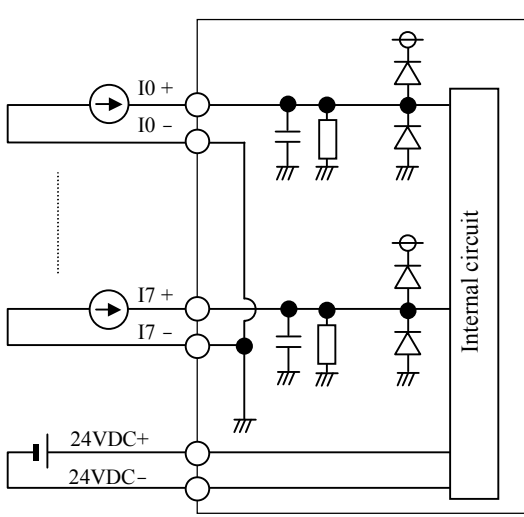
Terminal configuration	No.	Signal name	Diagram of Internal circuit
	[1]	I0 +	
	[2]	I1 +	
	[3]	I2 +	
	[4]	I3 +	
	[5]	I4 +	
	[6]	I5 +	
	[7]	I6 +	
	[8]	I7 +	
	[9]	24 VDC +	
	[10]	I0 -	
	[11]	I1 -	
	[12]	I2 -	
	[13]	I3 -	
	[14]	I4 -	
	[15]	I5 -	
	[16]	I6 -	
	[17]	I7 -	
	[18]	24 VDC -	

Relation between analog and digital data

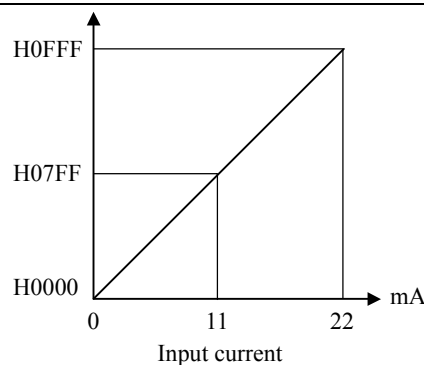

(6) EH-AY22

Specification		EH-AY22
Current range		4 to 20mA
Voltage range		0 to 10V DC
Number of channels	Current	2 (Ch.2 to 3)
	Voltage	2 (Ch.0 to 1)
Resolution		12 bits
Conversion time		5ms maximum
Overall accuracy		±1% maximum of full-scale
External load resistance	Current	500Ω maximum
	Voltage	10kΩ minimum
Insulation system	Channel and Internal circuit	Photo-coupler insulation
	Between channels	No insulation
External connection		Removable type screw terminal block (M3)
External power supply		24V DC (+20%, -15%) Approx. 150mA (Approx. 500mA at power ON)
External wiring		2-core shield cable (20m (65.62ft.) maximum)
Internal current consumption		100mA maximum

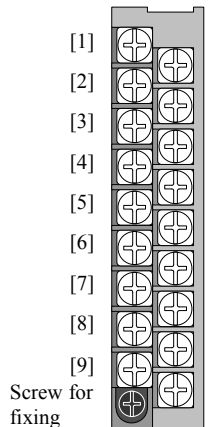
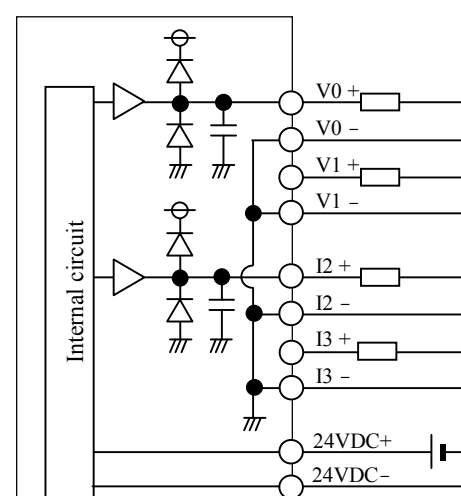
Terminal configuration	No.	Signal name	Diagram of Internal circuit
	[1]	V0 +	
	[2]	V1 +	
	[3]	I2 +	
	[4]	I3 +	
	[5]	N.C.	
	[6]	N.C.	
	[7]	N.C.	
	[8]	N.C.	
	[9]	24 VDC +	
	[10]	V0 -	
	[11]	V1 -	
	[12]	I2 -	
	[13]	I3 -	
	[14]	N.C.	
	[15]	N.C.	
	[16]	N.C.	
	[17]	N.C.	
	[18]	24 VDC -	

Relation between analog and digital data

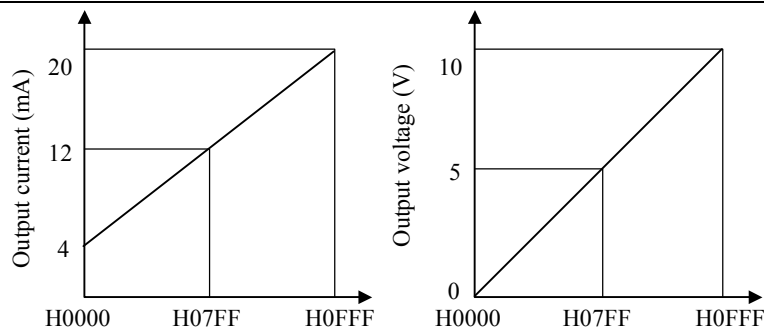

(7) EH-AY2H

Specification		EH-AY2H
Voltage range		-10 to +10V DC
Number of channels		2
Resolution		12 bits
Conversion time		5ms maximum
Overall accuracy		± 1% maximum of full-scale
External load resistance		10k Ω minimum
Insulation system	Channel and Internal circuit	Photo-coupler insulation
	Between channels	No insulation
External connection		Removable type screw terminal block (M3)
External power supply		24V DC (+20%, -15%) Approx. 150mA (Approx. 500mA at power ON)
External wiring		2-core shield cable (20m (65.62ft.) maximum)
Internal current consumption		100mA maximum

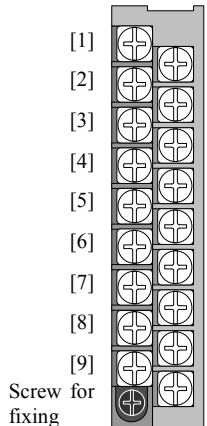
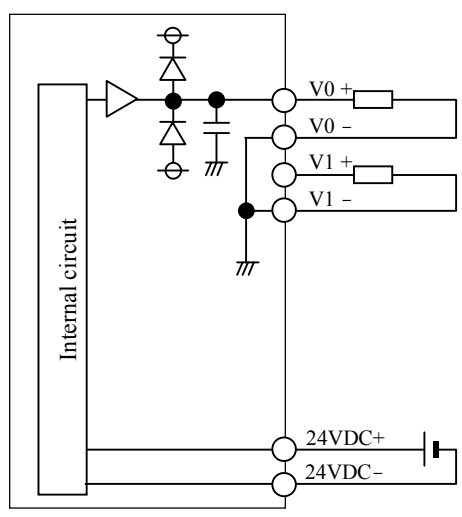
Terminal configuration	No.	Signal name	Diagram of Internal circuit
 <p>Screw for fixing</p>	[1]	V0 +	
	[2]	V1 +	
	[3]	N.C.	
	[4]	N.C.	
	[5]	N.C.	
	[6]	N.C.	
	[7]	N.C.	
	[8]	N.C.	
	[9]	24 VDC +	
	[10]	V0 -	
	[11]	V1 -	
	[12]	N.C.	
	[13]	N.C.	
	[14]	N.C.	
	[15]	N.C.	
	[16]	N.C.	
	[17]	N.C.	
	[18]	24 VDC -	

Relation between analog and digital data

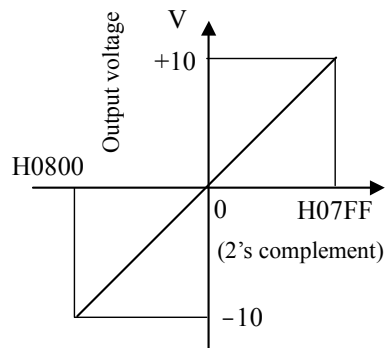

(8) EH-AY4I

Specification		EH-AY4I
Current range		4 to 20mA
Number of channels		4
Resolution		12 bits
Conversion time		5ms maximum
Overall accuracy		± 1% maximum of full-scale
External load resistance		350 Ω maximum
Insulation system	Channel and Internal circuit	Photo-coupler insulation
	Between channels	No insulation
External connection		Removable type screw terminal block (M3)
External power supply		24V DC (+20%, -15%) Approx. 150mA (Approx. 500mA at power ON)
External wiring		2-core shield cable (20m (65.62ft.) maximum)
Internal current consumption		130mA maximum

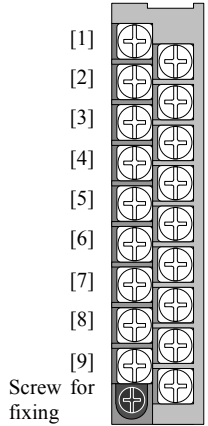
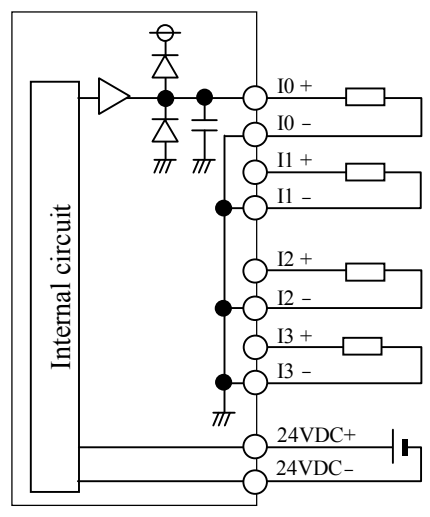
Terminal configuration	No.	Signal name	Diagram of Internal circuit
	[1]	I0 +	
	[2]	I1 +	
	[3]	I2 +	
	[4]	I3 +	
	[5]	N.C.	
	[6]	N.C.	
	[7]	N.C.	
	[8]	N.C.	
	[9]	24 VDC +	
	[10]	I0 -	
	[11]	I1 -	
	[12]	I2 -	
	[13]	I3 -	
	[14]	N.C.	
	[15]	N.C.	
	[16]	N.C.	
	[17]	N.C.	
	[18]	24 VDC -	

Relation between analog and digital data

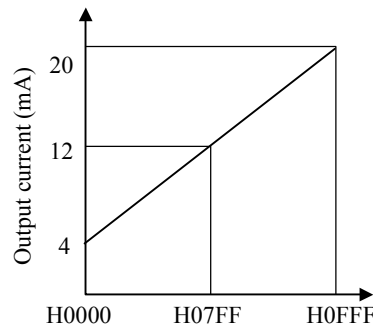

(9) EH-AY4V

Specification		EH-AY4V
Voltage range		0 to 10V DC
Number of channels		4
Resolution		12 bits
Conversion time		5ms maximum
Overall accuracy		±1% maximum of full-scale
External load resistance		10kΩ minimum
Insulation system	Channel and Internal circuit	Photo-coupler insulation
	Between channels	No insulation
External connection		Removable type screw terminal block (M3)
External power supply		24V DC (+20%, -15%) Approx. 150mA (Approx. 500mA at power ON)
External wiring		2-core shield cable (20m (65.62ft.) maximum)
Internal current consumption		100mA maximum

Terminal configuration	No.	Signal name	Diagram of Internal circuit
	[1]	V0 +	
	[2]	V1 +	
	[3]	V2 +	
	[4]	V3 +	
	[5]	N.C.	
	[6]	N.C.	
	[7]	N.C.	
	[8]	N.C.	
	[9]	24 VDC +	
	[10]	V0 -	
	[11]	V1 -	
	[12]	V2 -	
	[13]	V3 -	
	[14]	N.C.	
	[15]	N.C.	
	[16]	N.C.	
	[17]	N.C.	
	[18]	24 VDC -	

Relation between analog and digital data

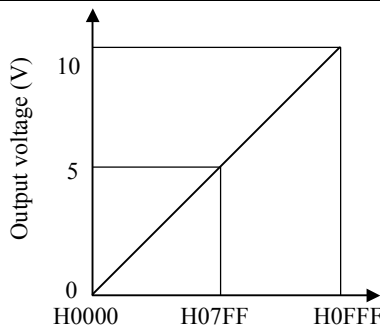

(10) EH-AY4H

Specification		EH-AY4H
Voltage range		-10 to +10V DC
Number of channels		4
Resolution		12 bits
Conversion time		5ms maximum
Overall accuracy		±1% maximum of full-scale
External load resistance		10k Ω minimum
Insulation system	Channel and Internal circuit	Photo-coupler insulation
	Between channels	No insulation
External connection		Removable type screw terminal block (M3)
External power supply		24V DC (+20%, -15%) Approx. 150mA (Approx. 500mA at power ON)
External wiring		2-core shield cable (20m (65.62ft.) maximum)
Internal current consumption		100mA maximum

Terminal configuration	No.	Signal name	Diagram of Internal circuit
	[1]	V0 +	
	[2]	V1 +	
	[3]	V2 +	
	[4]	V3 +	
	[5]	N.C.	
	[6]	N.C.	
	[7]	N.C.	
	[8]	N.C.	
	[9]	24 VDC +	
	[10]	V0 -	
	[11]	V1 -	
	[12]	V2 -	
	[13]	V3 -	
	[14]	N.C.	
	[15]	N.C.	
	[16]	N.C.	
	[17]	N.C.	
	[18]	24 VDC -	

Relation between analog and digital data

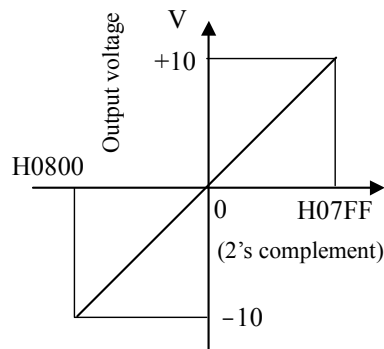

2.8.2 High resolution analog modules

(1) EH-AXH8M

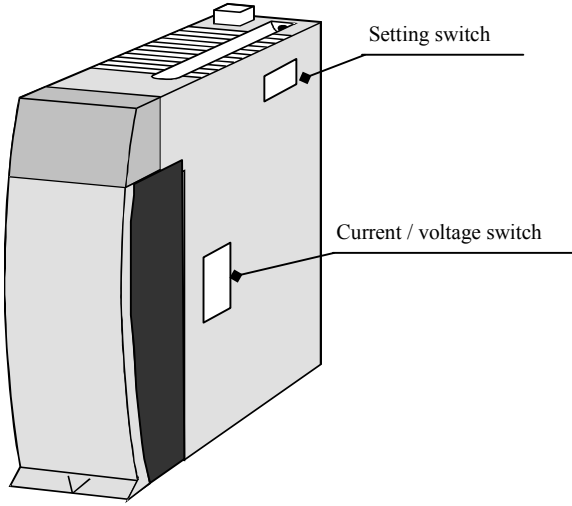
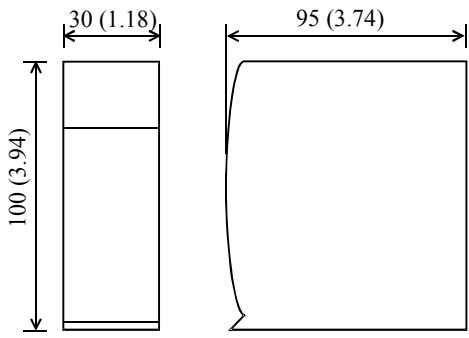
Module features		Type (Weight)	EH-AXH8M (Approx. 0.15kg (0.34lb.))
EH-AXH8M			EH-AYH8M (Approx. 0.18kg (0.41lb.))
	Dimensions (mm (in.))		
			

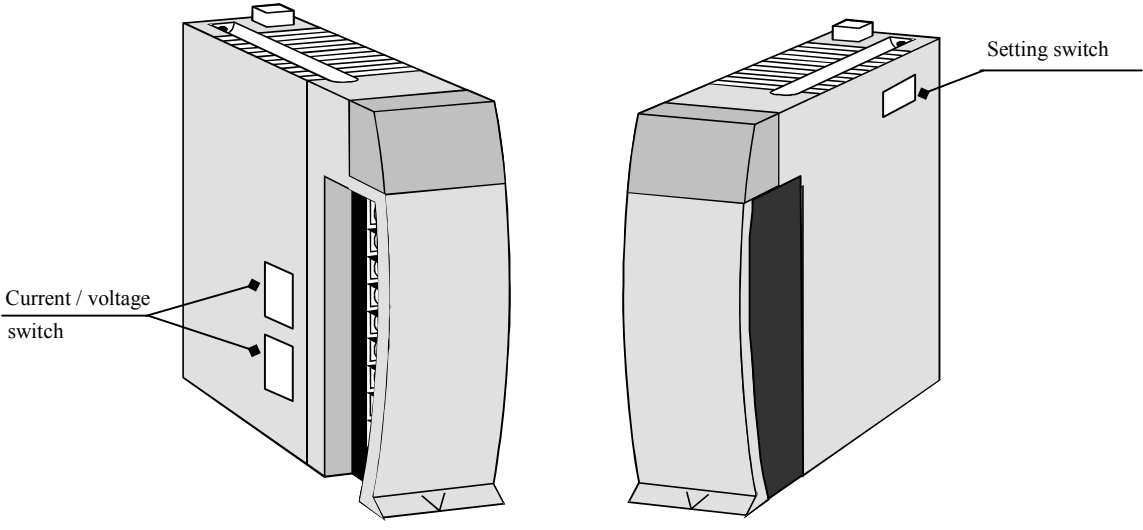
EH-AYH8M			
----------	---	--	--

Name	Description
Setting switch	configures I/O range, input filter and resolution mode.
Current / voltage switch	configures current or voltage.

Front view	Indicating contents
	<p>OK LED ON: the module is operating in normal condition. 0 to 7 LED OFF: analog signal is operating in normal condition.</p> <p>[EH-AXH8M] If analog signal is less than 2mA, corresponding number LED flashes. (Valid only when 4 to 22mA mode with 0.002mA resolution is selected.)</p> <p>[EH-AYH8M] If data out of the range is written, corresponding number LED flashes.</p>

Specification		EH-AXH8M
Current range		0 to 22mA / 4 to 22mA
Voltage range		0 to 10V DC / -10 to +10V DC
Number of channels		8 (current or voltage is selected in 4-ch group.)
Resolution	Current	0.002mA or 1/16384 (14 bits)
	Voltage	1mV or 1/16384 (14 bits)
Conversion time		8.9ms / 8 channels
Overall accuracy	Current	±0.8% maximum of full-scale
	Voltage	±0.5% maximum of full-scale
Linear error		±0.1% maximum of full-scale
Input filter	Enabled	Approx. 90ms maximum (90% arriving time after the step input)
	Disabled	Approx. 18ms maximum (90% arriving time after the step input)
Input impedance	Current	249 Ω
	Voltage	Differential 200k Ω
Insulation system	Channel and Internal circuit	Photo-coupler insulation
	Between channels	No insulation
External connection		Removable type screw terminal block (M3)
External power supply		24V DC (+20%, -15%) Approx. 40mA (Approx. 300mA at power ON)
External wiring		2-core shield cable (20m (65.62ft.) maximum)
Internal current consumption		70mA maximum

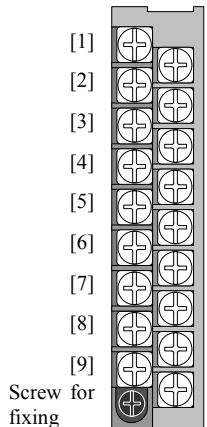
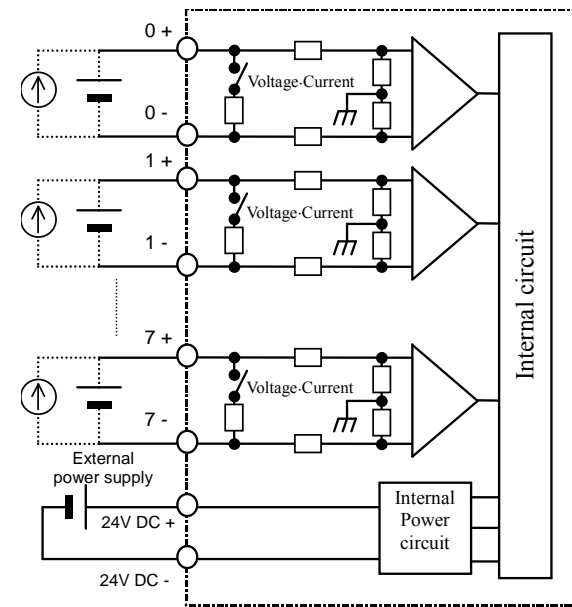
Terminal configuration	No.	Signal name	Diagram of Internal circuit
	[1]	0 +	
	[2]	1 +	
	[3]	2 +	
	[4]	3 +	
	[5]	4 +	
	[6]	5 +	
	[7]	6 +	
	[8]	7 +	
	[9]	24VDC+	
	[10]	0 -	
	[11]	1 -	
	[12]	2 -	
	[13]	3 -	
	[14]	4 -	
	[15]	5 -	
	[16]	6 -	
	[17]	7 -	
	[18]	24VDC-	

Setting switch					Support to analog data and digital data	
Switch No.	Setup		Function			
1, 2	1	2	Input range setting for ch.0 to 3			
	OFF	OFF	0 to 10 V DC			
	ON	OFF	-10 to +10 V DC			
	OFF	ON	0 to 22 mA			
	ON	ON	4 to 22 mA			
3, 4	3	4	Input range setting for ch.4 to 7			
	OFF	OFF	0 to 10 V DC			
	ON	OFF	-10 to 10 V DC			
	OFF	ON	0 to 22 mA			
	ON	ON	4 to 22 mA			
5	5		Input filter			
	OFF		Enable			
	ON		Disable			
6	6		Resolution			
	OFF		1/16384 (14 bits)			
	ON		1mV or 0.002mA			
7	7		(System mode)			
	OFF		Always OFF (Do not turn ON)			
8	8		(System mode)			
	OFF		Always OFF (Do not turn ON)			
Current / Voltage switch						
Switch No.	Setup		Function			
1 to 8	1 to 4	5 to 8	Select current or voltage			
	OFF	OFF	voltage input for ch.0 to 7			
	ON	OFF	current input for ch.0 to 3 voltage input for ch.4 to 7			
	OFF	ON	voltage input for ch.0 to 3 current input for ch.4 to 7			
	ON	ON	current input for ch.0 to 7			

[Highlighted part is factory default setting.]

Note) Be sure to set dip switches before use. The dip switches must be set while power off, otherwise setting status is not updated.
When the input range is changed, be sure to set current / voltage switch accordingly.

(2) EH-AYH8M

Specification		EH-AYH8M
Current range		0 to 22mA / 4 to 22mA
Voltage range		0 to 10V DC
Number of channels		8 (current or voltage is selected in 4-ch group.)
Resolution	Current	0.002mA or 1/16384 (14 bits)
	Voltage	1mV or 1/16384 (14 bits)
Conversion time		8.9ms / 8 channels
Overall accuracy	Current	±0.8% maximum of full-scale
	Voltage	±0.8% maximum of full-scale
Linear error		±0.2% maximum of full-scale) (range from 0 to 10V and from 0.05 to 22mA)
Output filter	Enabled	Approx. 200ms maximum (90% arriving time after setting)
	Disabled	Approx. 18ms maximum (90% arriving time after setting)
Output impedance	Current	400 Ω maximum
	Voltage	10k Ω minimum
Insulation system	Channel and Internal circuit	Photo-coupler insulation
	Between channels	No insulation
External connection		Removable type screw terminal block (M3)
External power supply		24V DC (+20%, -15%) Approx. 150mA (Approx. 400mA at power ON)
External wiring		2-core shield cable (20m (65.62ft.) maximum)
Internal current consumption		70mA maximum

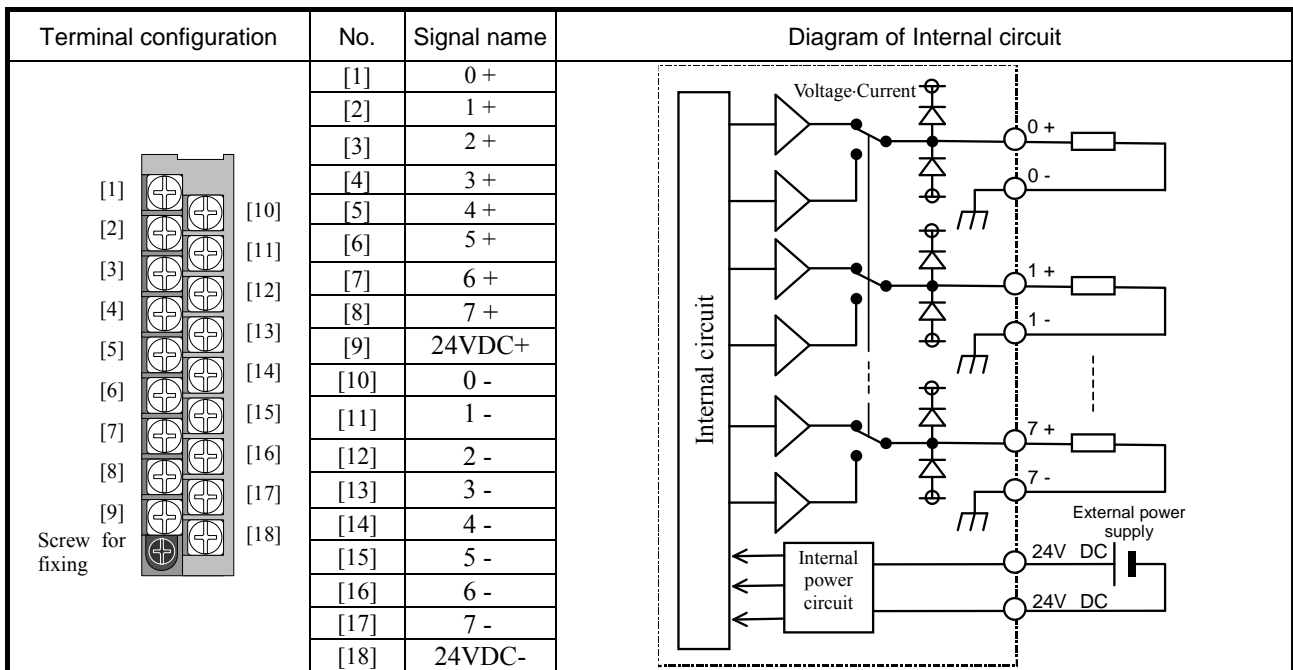

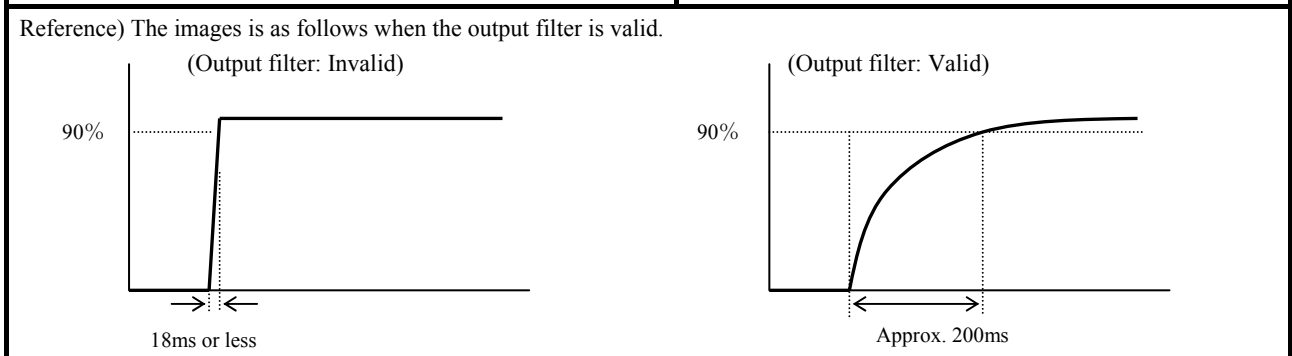
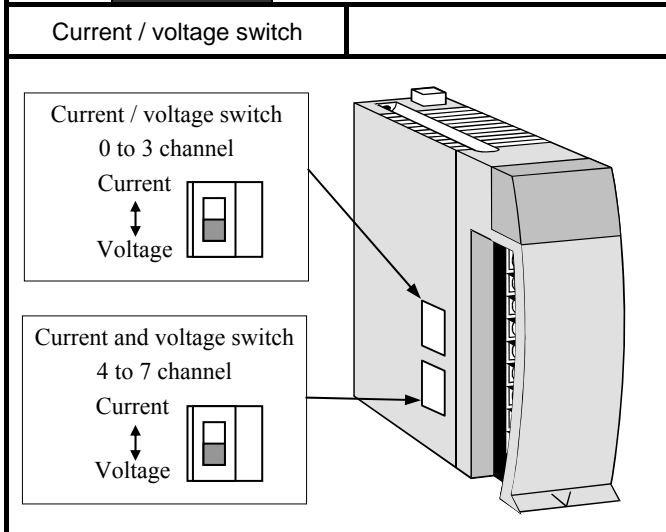
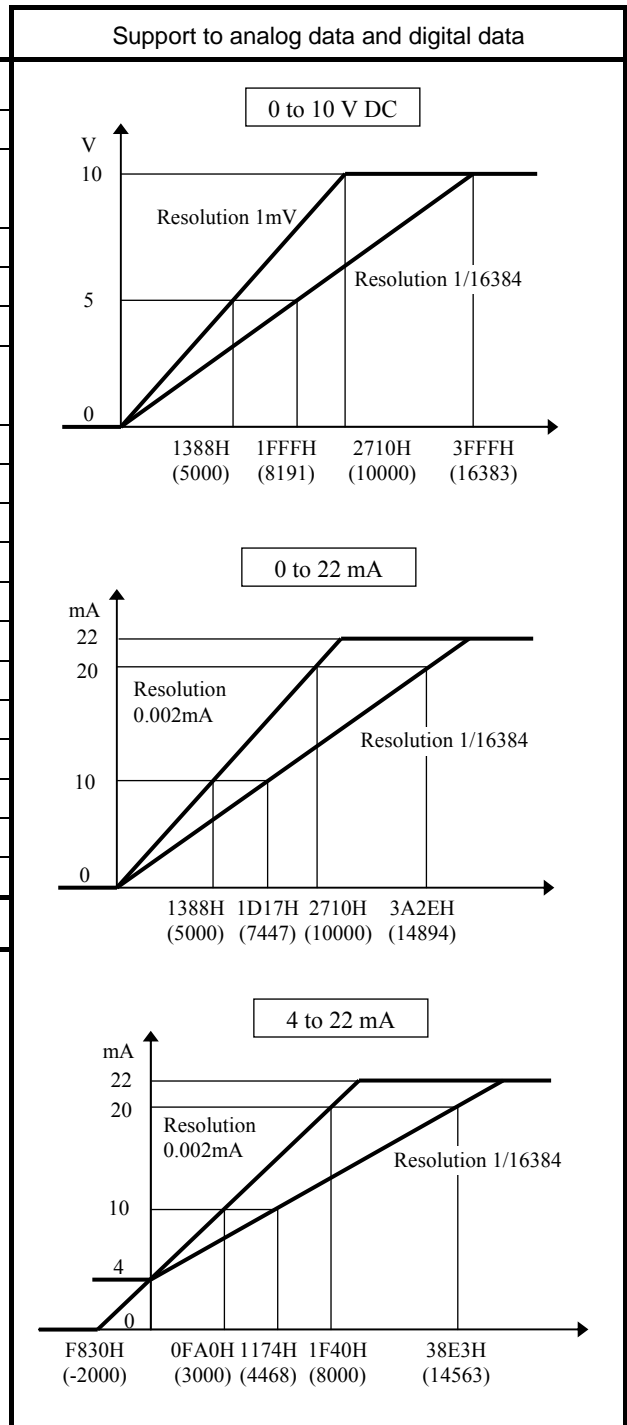

Setting switch			
No.	Setup		Function
1, 2	1	2	Output range setting for ch.0 to 3
	OFF	OFF	0 to 10 V DC
	ON	OFF	
	OFF	ON	0 to 22 mA
	ON	ON	4 to 22 mA
3, 4	3	4	Output range setting for ch.4 to 7
	OFF	OFF	0 to 10 V DC
	ON	OFF	
	OFF	ON	0 to 22 mA
	ON	ON	4 to 22 mA
5	5		Output filter
	OFF		Disable
	ON		Enable
6	6		Resolution
	OFF		1/16384 (14 bits)
	ON		1mV or 0.002mA
7	7		(System mode)
	OFF		Always OFF (Do not turn ON)
8	8		(System mode)
	OFF		Always OFF (Do not turn ON)



[Highlighted part is factory default setting.]

Note) Be sure to set dip switches before use. The dip switches must be set while power off, otherwise setting status is not updated. When the input range is changed, be sure to set current / voltage switch accordingly.

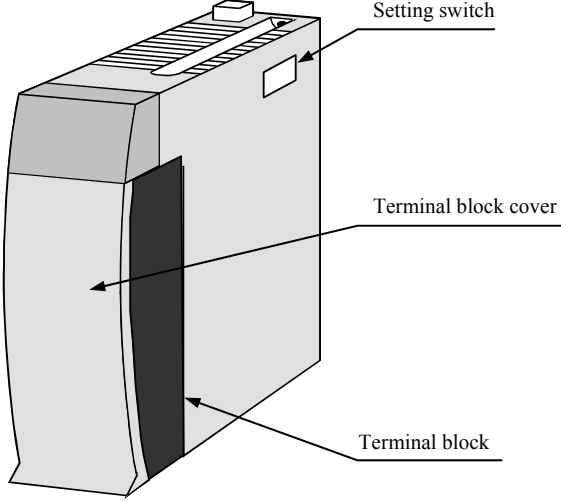
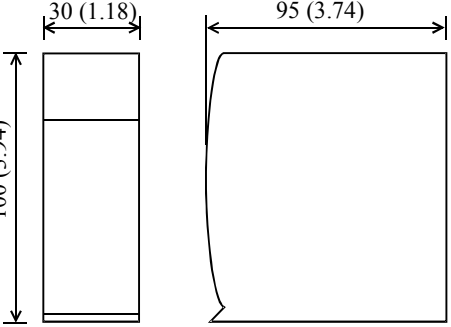
2.8.3 Isolated analog modules

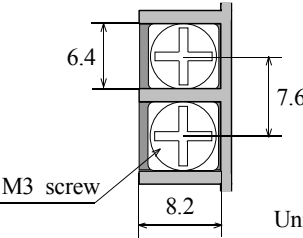
Module features		Type (Weight)	EH-AXG5M (Approx. 0.15kg (0.34lb.))
			EH-AYG4M (Approx. 0.15kg (0.34lb.))
	Dimensions (mm (in.))		
Name	Description		
Terminal block	<p>The terminal block is to connect I/O signals. It is removable type. The screw size is M3.</p> <p>Use a suitable sized crimping terminal for the screw. The terminal block supports 0.3 to 2mm² (AWG22 to 14). However, recommended cable is from 0.5 to 0.75mm² (AWG20 to 18). If 2 crimping terminals are connected to one terminal screw, use 0.5mm² (AWG20) cable.</p> <p>The recommended crimping terminal is indicated as below.</p> <div style="display: flex; align-items: center;">  <div style="margin-left: 20px;">(Recommended)</div> </div> <div style="display: flex; align-items: center; margin-top: 10px;">  <div style="margin-left: 20px;"> <p>Handle very carefully since cable could be detached when screw is loose.</p> </div> </div> <div style="text-align: center; margin-top: 5px;">Unit: mm (in.)</div> <div style="float: right; text-align: center; margin-top: 10px;">  <p>M3 screw</p> <p>Unit: in.</p> </div>		
Terminal block cover	This is a covert for installing on the terminal block.		
Setting switch	configures input range, input filter and resolution mode.		

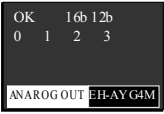
Front view	Indicating contents
 	<p>[EH-AXG5M]</p> <p>OK: Light up when this module is normal</p> <p>HS: Light up when this module is high speed conversion mode</p> <p>Light is turned off when this module is high accuracy mode</p> <p>16b: Light up when this module is high resolution mode</p> <p>12b: Light up when this module is 12 bit resolution mode</p> <p>0 to 4: In case of 4 to 22mA range, if input current is less than 2mA the LED of each channel is blinking.</p> <p>[EH-AYH8M]</p> <p>OK: Light up when this module is normal</p> <p>16b: Light up when this module is high resolution mode</p> <p>12b: Light up when this module is 12 bit resolution mode</p> <p>0 to 3: In case of current range, LED of each channel is blinking when wire breaking or out of data range was detected.</p>

(1) EH-AXG5M

Specification		EH-AXG5M	
Number of channel		Differential 5 voltage or 5 current input	
Input range Selectable by the DIP switch	Voltage	0 to 10 V DC	
		-10 to 10 V DC	
	Current	0 to 22 mA	
		4 to 22 mA	
Resolution Selectable by the DIP switch	High resolution mode		12 bit mode
	0 to 10 V	0 to 64000 [0.15625 mV]	0 to 4095 [2.442 mV]
	-10 to 10 V	-32000 to 32000 [0.3125 mV]	-2048 to 2047 [4.884 mV]
	0 to 22 mA	0 to 64000 [0.34375 μ A]	0 to 4095 (20mA) [4.884 μ A]
	4 to 22 mA	-7111 to 32000 [0.5625 μ A]	0 to 4095 (20mA) [3.907 μ A]
Conversion time		High accuracy 8 ms / 5 channel	High speed 0.25 ms / 5 channel
Accuracy (FS) *1	At 25 °C	-0.05 to +0.05 %	
	Temperature coefficient	-80 to +80 ppm / °C (0.008 %/ °C)	
Input filter		1 kHz	
Input impedance	Voltage	Differential 200 k Ω	
	Current	249 Ω	
Warm up time		More than 15 minutes	
Absolute maximum ratings		Voltage: -15 to 15 V Current :30 mA*2	
Isolation type	Channel - internal circuit	Transformer (1,000V AC、1 minutes)	
	Between channels	Transformer (1,000V DC、1 minutes)	
Weight		Approximately 0.15 kg	
External wiring		Removable terminal (M3)	
Internal current consumption (5 V DC)		Max. 300mA	
External power wiring		None	
Wiring		Twisted shield cable (2-pair, less than 20 m)	

*1: e.g. Accuracy at 40 °C is calculated as follows,

$$0.05 \% (\text{accuracy at } 25 \text{ } ^\circ\text{C}) + 0.008 \% / \text{ } ^\circ\text{C} (\text{Temperature coefficient}) * 15 \text{ } ^\circ\text{C} (\text{difference from } 25 \text{ } ^\circ\text{C}) = 0.17 \%$$

*2: It is the momentary current value that does not destroy the resistance in the module.

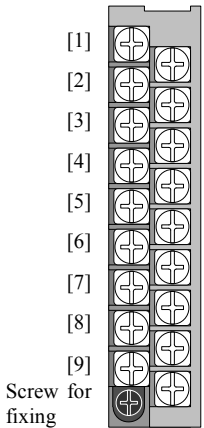
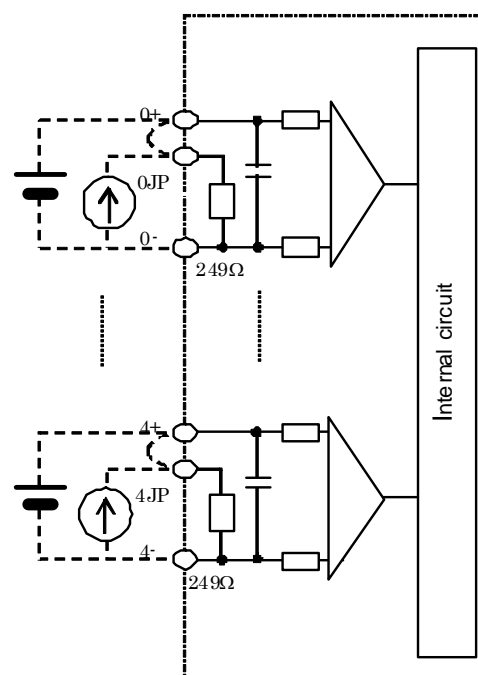
Terminal configuration	No.	Signal name	Diagram of Internal circuit
	[1]	(NC)	
	[2]	(NC)	
	[3]	0-	
	[4]	1 +	
	[5]	1 JP	
	[6]	2 -	
	[7]	3 +	
	[8]	3 JP	
	[9]	4 -	
	[10]	(NC)	
	[11]	0 +	
	[12]	0 JP	
	[13]	1 -	
	[14]	2 +	
	[15]	2 JP	
	[16]	3 -	
	[17]	4 +	
	[18]	4 JP	

Setting switch			
Switch No.	Setup		Function
1, 2	1	2	Input range setting for ch.0 to 4
	OFF	OFF	0 to 10 V DC
	ON	OFF	-10 to +10 V DC
	OFF	ON	0 to 22 mA
	ON	ON	4 to 22 mA
3, 4	3	4	Moving Average data number
	OFF	OFF	Not use moving Average
	ON	OFF	4
	OFF	ON	16
	ON	ON	64
5	5		Resolution
	OFF		High resolution mode (equally 16 bit)
	ON		12 bit mode
6	6		Conversion time
	OFF		High accuracy, 8ms (whole channel)
	ON		High speed, 0.25ms (whole channel)
7	7		(System mode)
	OFF		Always OFF (Do not turn ON)
8	8		(System mode)
	OFF		Always OFF (Do not turn ON)

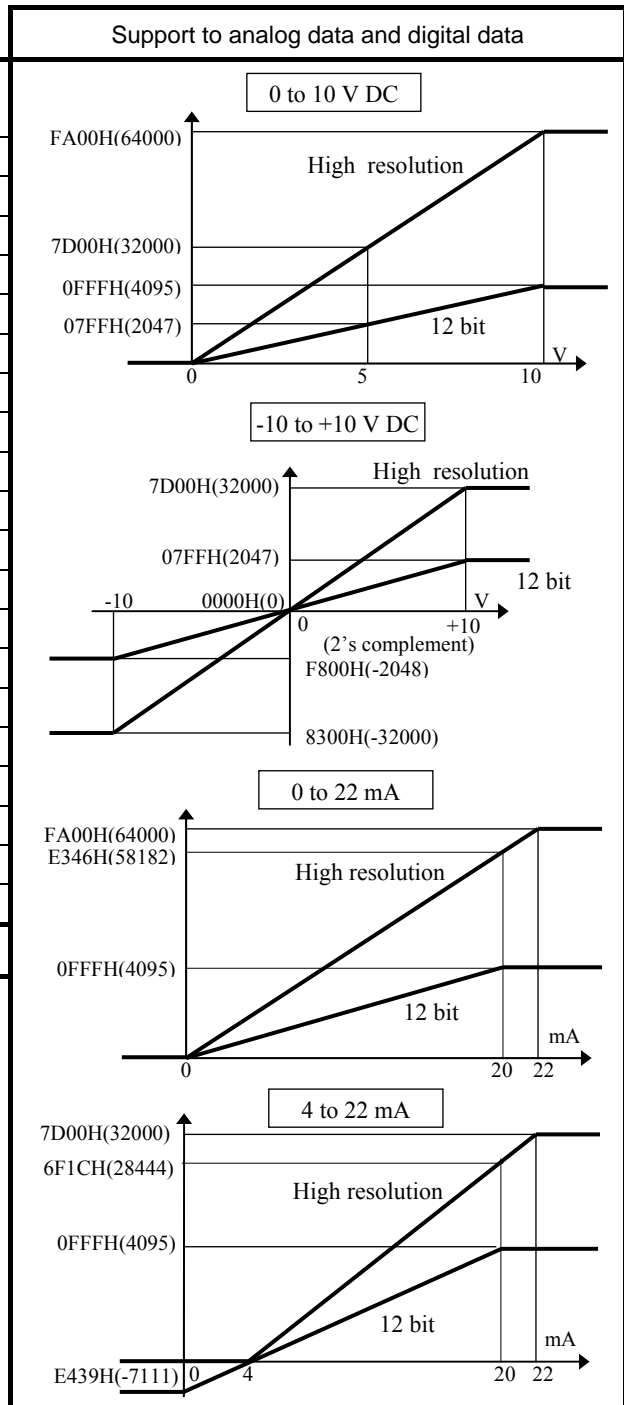

Protection Sheet

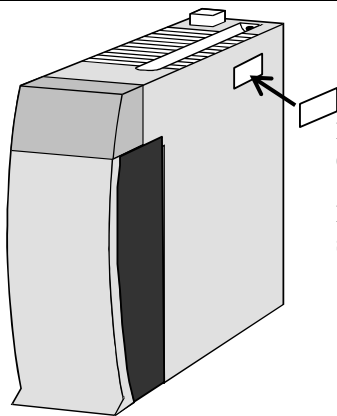

Protection sheet
(Packing with product)

Put the protection sheet after
setting for safety.

[Highlighted part is factory default setting.]

Note) In case switch 5 turn OFF and switch 6 turn ON, It is available High resolution and High speed mode (16bit, 0.25ms). Please be careful using this mode because this mode is very sensitive for noise.

(2) EH-AYG4M

Specification		EH-AYG4M	
Number of channel		Differential 4 voltage or 4 current output	
Output range Selectable by the DIP switch	Voltage	0 to 10 V DC	
		-10 to 10 V DC	
	Current	0 to 22 mA	
		4 to 22 mA	
Resolution Selectable by the DIP switch	High resolution mode		12 bit mode
	0 to 10 V	0 to 64000 [0.15625 mV]	0 to 4095 [2.442 mV]
	-10 to 10 V	-32000 to 32000 [0.3125 mV]	-2048 to 2047 [4.884 mV]
	0 to 22 mA	0 to 64000 [0.34375 μ A]	0 to 4095 (20mA) [4.884 μ A]
	4 to 22 mA	-7111 to 32000 [0.5625 μ A]	0 to 4095 (20mA) [3.907 μ A]
Conversion time		0.25 ms / 4 channel	
Accuracy (FS) *1	At 25 °C	-0.1 % to +0.1%	
	Temperature coefficient	-80 to +80 ppm / °C (0.008 %/ °C)	
Input impedance	Voltage	More than 1 k Ω	
	Current	Less than 600 Ω	
Warm up time		More than 15 minutes	
Absolute maximum ratings		Voltage:-15 to 15 V Current :24mA	
Isolation	Channel - internal circuit	Transformer isolation (1,000V AC、1 minutes)	
	Between channels	Transformer isolation (1,000V DC、1 minutes)	
Weight		Approximately 0.15 kg	
External wiring		Removable terminal (M3)	
Internal current consumption (5 V DC) *2		Max. 730mA	
External power wiring		None	
Wiring		Twisted shield cable(2-pair, less than 20 m)	

*1: e.g. Accuracy at 40 °C is calculated as follows,

$$0.1 \% (\text{accuracy at } 25^{\circ}\text{C}) + 0.008 \% / ^{\circ}\text{C} (\text{Temperature coefficient}) * 15 ^{\circ}\text{C} (\text{difference form } 25 ^{\circ}\text{C}) = 0.22 \%$$

*2: 480mA (All channel output 10V voltage output with 10k Ω impedance)

600mA (All channel output 10V voltage output with 1k Ω impedance)

600mA (All channel output 11mA current output)

730mA (All channel output 22mA current output)

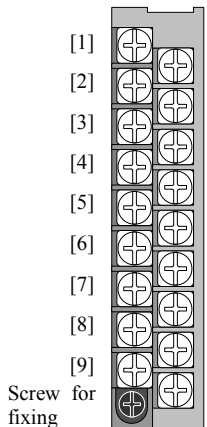
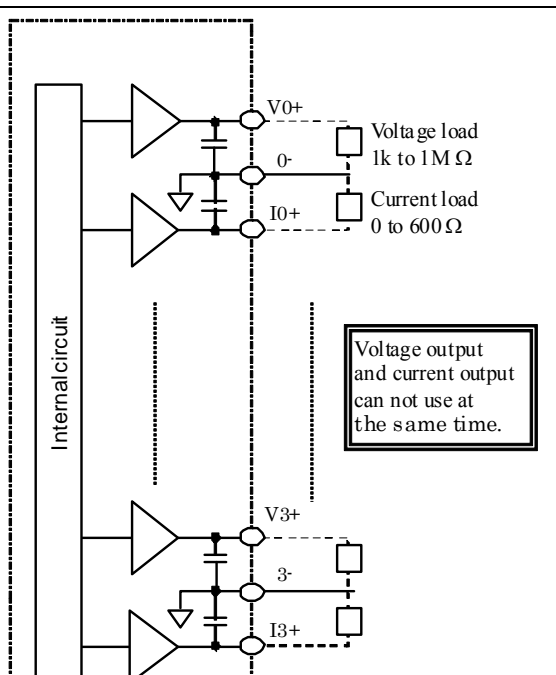
Terminal configuration	No.	Signal name	Diagram of Internal circuit
 <p>Screw for fixing</p>	[1]	(NC)	
	[2]	(NC)	
	[3]	0 -	
	[4]	(NC)	
	[5]	1 -	
	[6]	(NC)	
	[7]	2 -	
	[8]	(NC)	
	[9]	3 -	
	[10]	(NC)	
	[11]	V0 +	
	[12]	I0 +	
	[13]	V1 +	
	[14]	I1 +	
	[15]	V2 +	
	[16]	I2 +	
	[17]	V3 +	
	[18]	I3 +	

Setting switch			
No.	Setup	Function	
1, 2	1	2	Output range setting for ch.0 to 3
	OFF	OFF	0 to 10 V DC
	ON	OFF	-10 to 10 V DC
	OFF	ON	0 to 22 mA
	ON	ON	4 to 22 mA
3, 4	3	4	Slew Rate
	OFF	OFF	OFF
	ON	OFF	0.1 sec.
	OFF	ON	1 sec.
	ON	ON	10 sec.
5	5	Resolution	
	OFF	High resolution mode (equally 16 bit)	
	ON	12 bit mode	
6	6	(System mode)	
	OFF	Always OFF (Do not turn ON)	
7	7	(System mode)	
	OFF	Always OFF (Do not turn ON)	
8	8	(System mode)	
	OFF	Always OFF (Do not turn ON)	

Protection Sheet

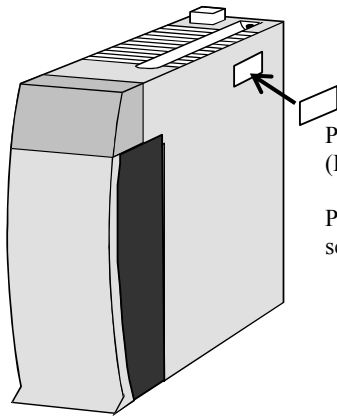

Protection sheet
(Packing with product)

Put the protection sheet after
setting for safety.

Support to analog data and digital data

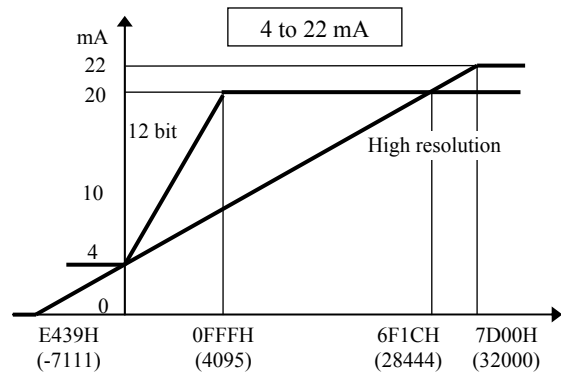
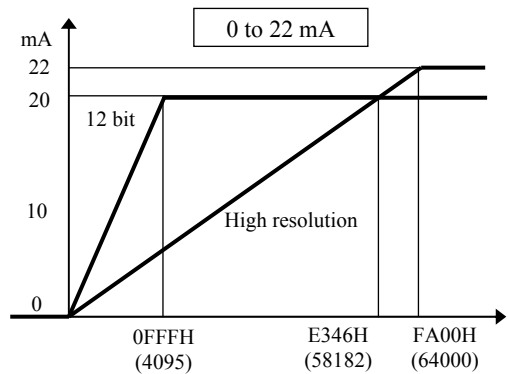
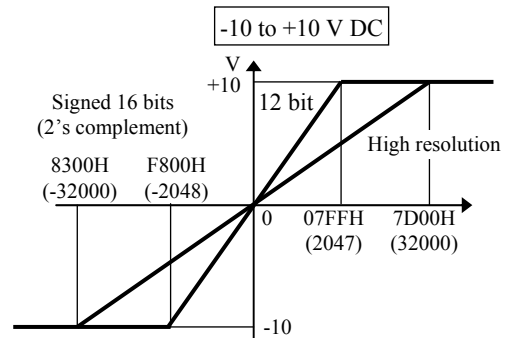
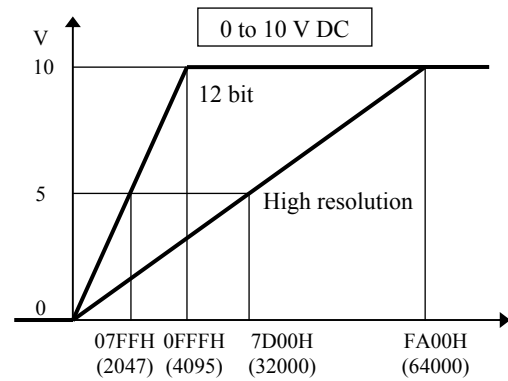

[Highlighted part is factory default setting.]

2.8.4 RTD input analog module

EH-PT4

<p>Module features</p>	<p>Type (Weight) EH-PT4 (Approx. 0.18kg (0.41lb.))</p> <p>Dimensions (mm (in.))</p>
------------------------	---

Name	Description
Terminal block	<p>The terminal block is to connect I/O signals. It is removable type. The screw size is M3.</p> <p>Use a suitable sized crimping terminal for the screw. The terminal block supports 0.3 to 2mm² (AWG22 to 14). However, recommended cable is from 0.5 to 0.75mm² (AWG20 to 18). If 2 crimping terminals are connected to one terminal screw, use 0.5mm² (AWG20) cable.</p> <p>The recommended crimping terminal is indicated as below.</p> <div style="display: flex; align-items: center;"> <div style="margin-left: 20px;">(Recommended)</div> </div> <div style="display: flex; align-items: center; margin-top: 10px;"> <div style="margin-left: 20px;"> <p>Handle very carefully since cable could be detached when screw is loose.</p> </div> </div> <div style="text-align: right; margin-top: 10px;"> <p>Unit: in.</p> </div>

Terminal block cover	This is a covert for installing on the terminal block.
----------------------	--

Setting switch	<p>Selects RTD type and range according to your system.</p> <table border="1" style="width: 100%; border-collapse: collapse; text-align: center;"> <thead> <tr> <th rowspan="2">Resistance temperature detector Measuring temperature range</th> <th colspan="8">Switch setup</th> </tr> <tr> <th>1</th> <th>2</th> <th>3</th> <th>4</th> <th>5</th> <th>6</th> <th>7</th> <th>8</th> </tr> </thead> <tbody> <tr> <td>Pt100 -20 to 40°C</td> <td>ON</td> <td>ON</td> <td>OFF</td> <td>OFF</td> <td>ON</td> <td>OFF</td> <td>OFF</td> <td>OFF</td> </tr> <tr> <td>Pt100 -50 to 400°C</td> <td>OFF</td> <td>OFF</td> <td>ON</td> <td>OFF</td> <td>OFF</td> <td>ON</td> <td>OFF</td> <td>OFF</td> </tr> <tr> <td>Pt1000 -50 to 400°C</td> <td>OFF</td> <td>OFF</td> <td>OFF</td> <td>ON</td> <td>OFF</td> <td>OFF</td> <td>ON</td> <td>OFF</td> </tr> </tbody> </table> <p>Be noted that temperature data is undefined value if configured as other than above.</p>	Resistance temperature detector Measuring temperature range	Switch setup								1	2	3	4	5	6	7	8	Pt100 -20 to 40°C	ON	ON	OFF	OFF	ON	OFF	OFF	OFF	Pt100 -50 to 400°C	OFF	OFF	ON	OFF	OFF	ON	OFF	OFF	Pt1000 -50 to 400°C	OFF	OFF	OFF	ON	OFF	OFF	ON	OFF
Resistance temperature detector Measuring temperature range	Switch setup																																												
	1	2	3	4	5	6	7	8																																					
Pt100 -20 to 40°C	ON	ON	OFF	OFF	ON	OFF	OFF	OFF																																					
Pt100 -50 to 400°C	OFF	OFF	ON	OFF	OFF	ON	OFF	OFF																																					
Pt1000 -50 to 400°C	OFF	OFF	OFF	ON	OFF	OFF	ON	OFF																																					

Specification		EH-PT4
Applicable resistance thermometer		Platinum resistance thermometer Pt100 (JIS C 1604-1989) / Pt1000
Temperature conversion data		Signed 15 bits
Accuracy *1	-20 to 40°C (Pt100)	±0.1°C @25°C (±0.5°C @0 to 55°C)
	-50 to 400°C (Pt100)	±0.6°C @25°C (±3°C @0 to 55°C)
	-50 to 400°C (Pt1000)	±0.8°C @25°C (±6°C @0 to 55°C)
Measuring temperature range		-20 to 40°C / -50 to 400°C (2mA constant current system)
Number of Input channels		4
Conversion time		Approx. 1s/4 channels
Insulation system	Channel and Internal circuit	Photo-coupler insulation
	Between channels	No insulation
External connection		Removable type screw terminal block (M3)
External power supply		24V DC
External wiring		Shield cable
Unused terminal processing		Temperature conversion data is H7FFF
External wiring resistance		Total resistance of 4 channels 400Ω at the maximum
Additional function		Linearization
Error detection *2		Data is H7FFF if measured value exceeds -51°C or 410°C
Wire breakage processing		Temperature conversion data is H7FFF
Internal current consumption		160mA maximum

*1 The accuracy indicates the value of 10 minutes after power up. The value may become slightly higher immediately after power up. Also check the resistance thermometer in advance because small error could exist in RTD.

*2 If Ax or Bx cable is open, data will be H7FFF. If bx cable is open, data will be undefined value.

Terminal configuration	No.	Signal name	Diagram of Internal circuit
	[1]	b0	
	[2]	B0	
	[3]	b1	
	[4]	B1	
	[5]	b2	
	[6]	B2	
	[7]	b3	
	[8]	B3	
	[9]	24V DC+	
	[10]	A0	
	[11]	N.C.	
	[12]	A1	
	[13]	N.C.	
	[14]	A2	
	[15]	N.C.	
	[16]	A3	
	[17]	N.C.	
	[18]	24V DC-	

EH-RTD8

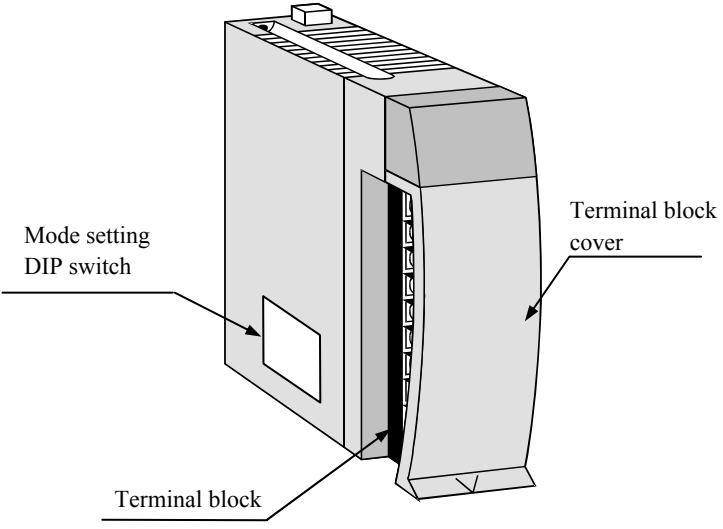
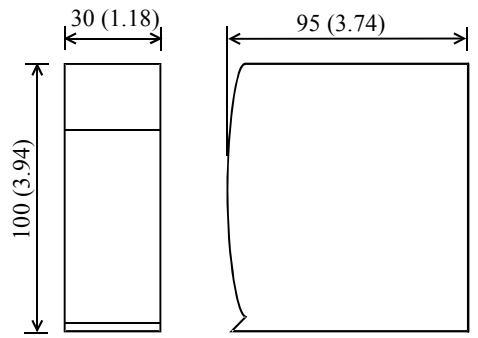
<p>Module features</p> 	Model name	EH-RTD8
	Weight	Approx. 0.15 kg
	Dimensions (mm (in.))	
		

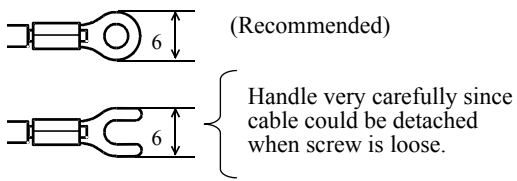
Item	Detail explanation
Terminal block	<p>The screws for the terminal block are M3 screws. Use a crimp terminal that fits the screw diameter. The maximum thickness of the cable should be only up to 0.75 mm². (Use 0.5 mm² cable when two crimp terminals are attached to the same terminal.)</p> <p>The recommended crimp terminal is indicated below.</p>  <p>Unit : mm</p>
Terminal block cover	This is a covert for installing on the terminal block.
Mode setting DIP switch	This switch is to configure parameters of EH-RTD8. Refer to page 2-77 for further information.

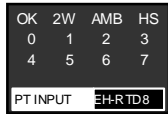
Front view	Indicating contents
	<p>The status of module and input signal are indicated in this LED.</p> <p>OK : Green : Normal status</p> <p>2W: Green : 2-wire mode / Off : 3-wire mode</p> <p>AMB : Green : -40 to 60°C mode / Off : -200 to 850°C mode</p> <p>HS : Green : High speed conversion time (0.5s) / Off : Normal conversion time (1.6s)</p> <p>0 to 7 : Blinking red : Open-wire or out-of-range is detected in corresponding channel number (0.5s cycle)</p>

Item		Specification		
Type		EH-RTD8		
Supported RTD type		PT100 / PT1000 (3-wire or 2-wire)		
Number of channel		6 (3-wire) or 8 (2-wire)		
Temperature range		-200 to 850°C or -40 to 60°C		
Resolution		°C conversion	°F conversion	PT4 compatible
		-200 to 850°C : 0.1°C	-328 to 1562°F : 0.1°F	-60 to 410°C : 15 bits
		-40 to 60°C : 0.02°C	—	-25 to 45°C : 15 bits
Conversion time		1.6s (all channels) or 0.5s (all channels)		
Accuracy *1	Standard accuracy (25°C)	Max. ±0.5°C (measured temperature under 380°C) Max. ±0.8°C (measured temperature over 380°C)		
	Temperature coefficient	±0.01% / °C (FS)*2 (±0.1°C / °C)		
Measurement current		0.18mA		
Diagnostic error (Wire breaking)	LED	LED blinking at error channel		
	Conversion value	H7FFF		
Input filter		None or moving average 16 times		
Warm-up time *3		1 minute		
Isolation	Channel to internal circuit	Photo coupler		
	Between channels	Not isolated		
Weight		Approximately 0.15 kg		
External wiring		Removable terminal (M3)		
Internal current consumption (5V DC)		Max. 300mA		
External power		None		
Wiring		Twisted shield cable, wiring resistance Max. 5Ω (Max. 100m of 22AWG)		

*1 Example : Measuring under 380°C in ambient temperature 35°C.(under noise-free environment)

$$0.5^{\circ}\text{C (standard accuracy)} + 0.1^{\circ}\text{C}/^{\circ}\text{C (temperature coefficient)} \times 10 (\text{difference to } 25^{\circ}\text{C}) = \pm 1.5^{\circ}\text{C}$$

*2 Full scale is -200 to 850°C.

*3 It is the time for data to be stable after power on.

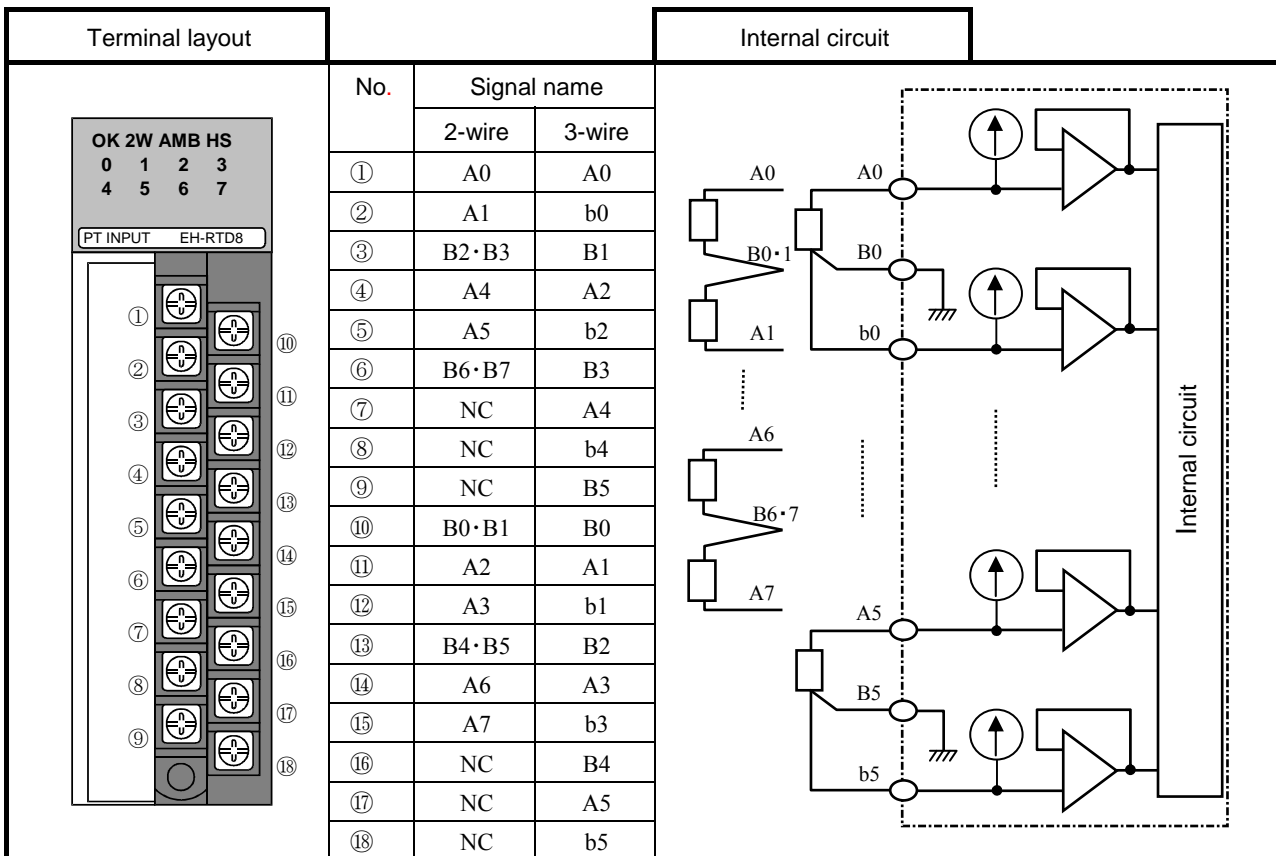

Dip switch settings

Please set the DIP switch before use. If changing the DIP switch while power on, the setting is not changed.

No.		Setting	Function
SW1-1	Wiring type	OFF	3-wire
		ON	2-wire
SW1-2	Temperature range	OFF	°C conversion : -200 to 850°C °F conversion : -328 to 1562°F EH-PT4 compatible : -60 to 410°C
		ON	°C conversion : -40 to 60°C °F conversion : -328 to 1562°F EH-PT4 compatible : -25 to 45°C
SW1-3	Input filter	OFF	None
		ON	16 times moving average
SW1-4	Conversion time	OFF	1.6s
		ON	0.5s
SW1-5	Temperature unit	OFF	°C
		ON	°F
SW1-6	EH-PT4 compatible mode	OFF	Disable
		ON	Enable
SW1-7	For system use	OFF	Set always OFF
SW1-8	For system use	OFF	Set always OFF
SW2	Sensor type	OFF	Pt1000
		ON	Pt100

Black colored statuses are factory default settings.

Conversion table



Range	Input	°C conversion	°F conversion	PT4 compatible	Remarks
-200 to 850°C	Under -200°C	-32768 (H8000)	-32768 (H8000)	H7FFF	
	-200°C	-2000	-3280	H7FFF	Measurement minimum
	-60°C	-600	-760	HF666	PT4 range minimum
	0°C	0	320	H0000	
	410°C	4100	7700	H4199	PT4 range maximum
	850°C	8500	15620	H7FFF	Measurement maximum
	Over 850°C	32767 (H7FFF)	32767 (H7FFF)	H7FFF	

Range	Input	°C conversion	°F conversion	PT4 compatible	Remarks
-40 to 60°C	Under -40°C	-32768 (H8000)	*1	H7FFF	
	-40°C	-4000		H7FFF	Measurement minimum
	-25°C	-2500		HD800	PT4 range minimum
	0°C	0		H0000	
	45°C	4500		H4800	PT4 range maximum
	60°C	6000		H7FFF	Measurement maximum
	Over 60°C	32767 (H7FFF)		H7FFF	

*1: Same as -200 to 850°C.

2.8.5 Thermocouple input analog module

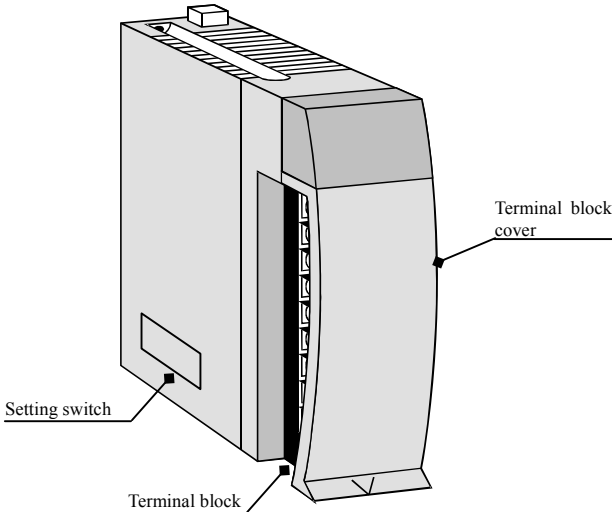
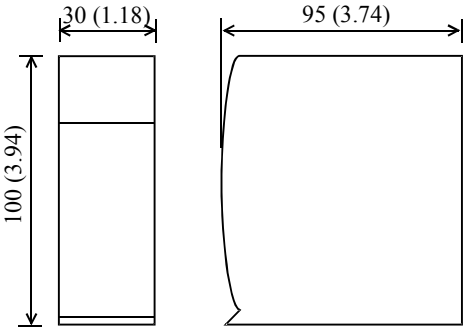
EH-TC8

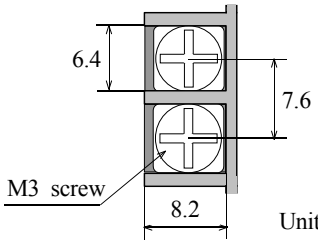
Module features		Type (Weight)	EH-TC8 (Approx. 0.16kg (0.35lb.))
		Dimensions (mm (in.))	
Name	Description		
Terminal block	<p>The terminal block is to connect I/O signals. It is removable type. The screw size is M3.</p> <p>Use a suitable sized crimping terminal for the screw. The terminal block supports 0.3 to 2mm² (AWG22 to 14). However, recommended cable is from 0.5 to 0.75mm² (AWG20 to 18). If 2 crimping terminals are connected to one terminal screw, use 0.5mm² (AWG20) cable.</p> <p>The recommended crimping terminal is indicated as below.</p> <div style="display: flex; align-items: center;">  (Recommended) </div> <div style="display: flex; align-items: center; margin-top: 10px;">  <div style="margin-left: 20px;"> <p>Handle very carefully since cable could be detached when screw is loose.</p> </div> </div> <div style="text-align: right; margin-top: 10px;">  <p>Unit: in.</p> </div>		
Terminal block cover	This is a cover for installing on the terminal block.		
Setting switch	Selects thermocouple types and Celsius/Fahrenheit, etc.		

Front view	Indicating contents
	<p>OK LED ON: the module is operating in normal condition.</p> <p>0 to 7 LED OFF: analog signal is operating in normal condition.</p> <p>0 to 7 LED Flash : Error status in corresponding number of channel.</p>

Specification		EH-TC8	
Applicable thermocouple types (selectable)		Conforms to JIS C 1602-1995 Type K, E, J, T, B, R, S, N	
Temperature conversion data		Signed 15 bits	
Measuring temperature range and accuracy *1	Type	Accuracy guaranteed range	Input range
	K	-200 to 1200°C 0.4% (FS)	-270 to 1370°C
	E	-200 to 900°C 0.3% (FS)	-270 to 1000°C
	J	-40 to 750°C 0.3% (FS)	-270 to 1200°C
	T	-200 to 350°C 0.8% (FS)	-270 to 400°C
	B	600 to 1700°C 1.0% (FS)	0 to 1820°C
	R	0 to 1600°C 1.0% (FS)	-50 to 1760°C
	S	0 to 1600°C 1.0% (FS)	-50 to 1760°C
N	-200 to 1200°C 0.4% (FS)	-270 to 1300°C	
Cold junction temperature error *2		±2°C maximum (Ambient temperature 15 to 35°C) ±3°C maximum (Ambient temperature 0 to 55°C)	
Resolution		0.1 °C / 0.1 ° F (K, E, J, T, N) 1.0 °C / 1.0 ° F (B, R, S)	
Number of Input channels		8	
Conversion time		108/860ms	
Insulation system	Channel and Internal circuit	Photo-coupler insulation	
	Between channels	No insulation	
External connection		Removable type screw terminal block (M3)	
External power supply		24V DC ±10% 100mA at the maximum	
External wiring *3		Shield cable	
Internal current consumption		70mA maximum	
Error detection	Over upper limit value / Breaking wiring detection	Data: H7FFF (corresponding number LED flashes.)	
	Under lower limit value	Data: H8000	

*1 The sum of accuracy of each sensor and the cold junction temperature error is the overall accuracy. Note that thermocouple device includes small level of error.

*2 Error is the value of 10 minutes after power up. Error may increase slightly due to quick change of ambient temperature.

*3 The maximum length of thermocouple wire is 100m (328ft.), however, it depends on environmental conditions.

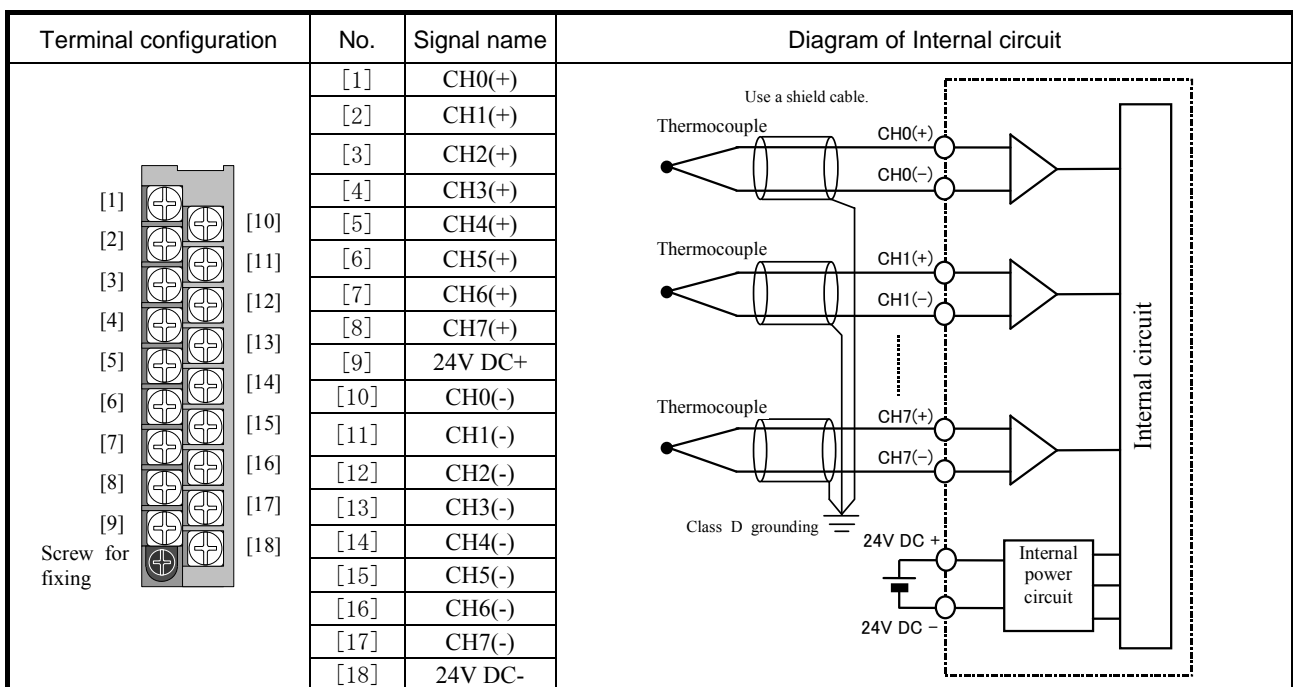

Item	Switch setup			Setting contents
	1	2	3	
Thermocouple sensor types (Common to all channels)	OFF	OFF	OFF	Type K
	ON	OFF	OFF	Type E
	OFF	ON	OFF	Type J
	ON	ON	OFF	Type T
	OFF	OFF	ON	Type B
	ON	OFF	ON	Type R
	OFF	ON	ON	Type S
	ON	ON	ON	Type N
Celsius (°C) / Fahrenheit (°F) switching (Common to all channels)	4			
	OFF			Celsius (°C)
	ON			Fahrenheit (°F)
Data updating cycle	5			
	OFF			860ms
	ON			108ms
Internal cold junction compensation	6			
	OFF			Cold junction compensation; Valid
	ON			Cold junction compensation; Invalid
(System mode)	7			
	OFF			Always OFF (Do not turn ON.)
	8			
	OFF			Always OFF (Do not turn ON.)

[Highlighted part is factory default setting.]

Note) Be sure to set dip switches before use. The dip switches must be set while power off, otherwise setting status is not updated.
When the input range is changed, be sure to set current / voltage switch accordingly.

Reference

If the internal cold junction compensation is disabled and high accurate ice-bus is installed externally, higher accuracy of temperature measurement would be achieved.

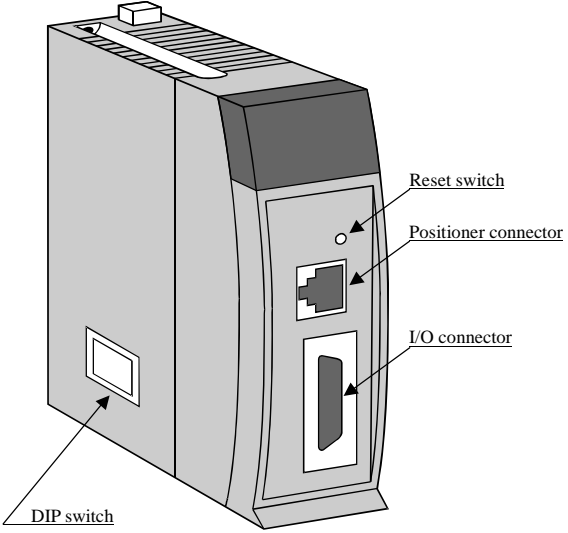
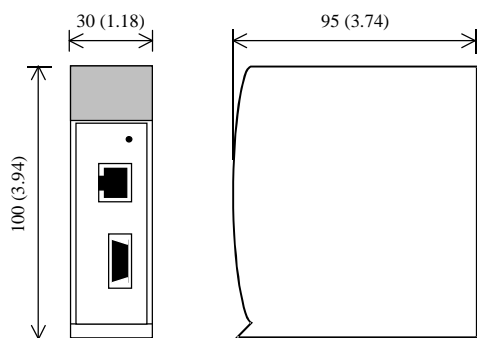
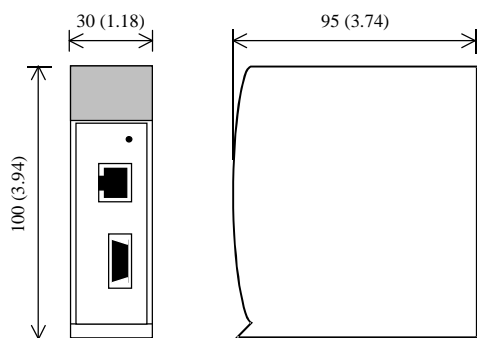
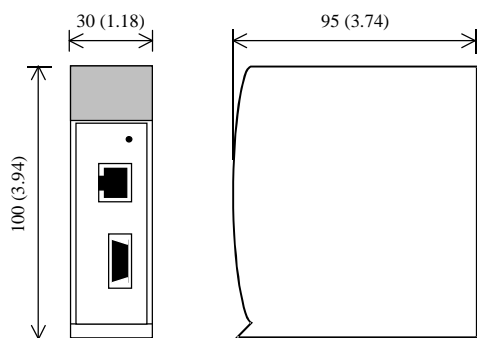

2.9 Special modules

2.9.1 Positioning module : EH-POS

<p>Module features</p> 	<table border="1"> <tr> <td>Type (Weight)</td> <td>EH-POS (Approx. 0.17kg (0.37lb.))</td> </tr> <tr> <td>Dimensions (mm (in.))</td> <td>  </td> </tr> </table>	Type (Weight)	EH-POS (Approx. 0.17kg (0.37lb.))	Dimensions (mm (in.))	
Type (Weight)	EH-POS (Approx. 0.17kg (0.37lb.))				
Dimensions (mm (in.))					

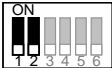
Name	Description
Reset switch	Hardware-reset switch.
Positioner connector	This is used for connecting a special programming console called positioner.
I/O connector	This is a connector (20 pins) for the pulse output and the external control input. Applicable connector Manufacturer: Sumitomo 3M Connecting system: 10120-3000VE (Soldering type) Shell: 10320-52F0-008 (or equivalents)
DIP switch	Switches the choice of pulse output method (CW/CCW or CK/Direction switching), output logic (positive/negative logic), and whether external input signal is in or not. Turn off the power and remove the module out of the base to change the setting.

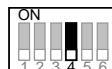
Purpose	Applied switch	Bit 1	Bit 2	Explanation
Choice of pulse output method	Bit 1-2 	OFF	OFF	Clock pulse / Direction signal output (Positive logic)
		OFF	ON	Clock pulse / Direction signal output (Negative logic)
		ON	OFF	CW/CCW pulse output (Positive logic)
		ON	ON	CW/CCW pulse output (Negative logic)

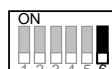
Purpose	Applied switch	Explanation	
Positioning complete external input signal Choice of (COIN) is in or not	Bit 4 	OFF	COIN signal
		ON	No COIN signal
+ Direction overrun external input signal Choice of (+0.RUN) is in or not	Bit 5 	OFF	+0.RUN signal
		ON	No +0.RUN
- Direction overrun external input signal Choice of (-0.RUN) is in or not	Bit 6 	OFF	-0.RUN signal
		ON	No -0.RUN signal

Always use Bit 3 with OFF.

Specifications

Item	Specification	
Number of control axes	1 axis	
Highest frequency	400 k pulse/s	
Positioning data	Capacity	256 points
	Setting procedure	1. Sequence program 2. Positioner (Note, a positioner is optional.)
Positioning	Method	1. Absolute system 2. Absolute system + Increment system 3. Increment system
	Positioning instruction	1. Pulse specifying 2. μm specifying 3. inch specifying 4. degree specifying
	Speed instruction	Automatic, manual, and homing 6.25 pulse/s to 400 k pulse/s $\mu\text{m/s}$, inch/s, degree/s input function
	Speed stage	10 stages
	Acceleration and deceleration system	Trapezoid acceleration and deceleration S-curve acceleration and deceleration (3-stage acceleration and deceleration)
	Acceleration and deceleration time	1 to 65,535 ms
	Backlash	0 to 255 pulse
	High and low limit setting	+2,147,483,647 to -2,147,483,648 pulse
	Pulse output method	1. Pulse chain (CW/CCW) 2. Clock + direction signal (CK/Direction) (DIP switch No.1 and No.2 set the choice of pulse output system and the switching of each positive and negative logic.)
	Pulse output procedure	1. Open collector output (Photo-coupler insulation) 2. Line driver output (Photo-coupler insulation)
Homing function	1. Free home position 2. Low speed homing 3. High speed homing 1 4. High speed homing 2 5. Absolute value encoder homing	
Teaching	Possible	
Manual (JOG) operation	Pulse output by manual input signal	
Operation when CPU has stopped	Operation is possible via I/O set or using the positioner	
Absolute value encoder input	Supports to Σ series / Σ II series by Yasukawa Electric Co. and P series by SANYO electric Co.	
Internal current consumption	300mA maximum	

(continued on the following page)

- Note
- When the CPU is stopped during operation, the motor decelerates and stops.
 - The maximum travel per one movement is 2,147,483,647 pulses. If the operation is performed exceeding the maximum travel, the motor decelerates and stops at the maximum travel position.

Specifications (continued from the preceding page)

Item		Specification	
Output	Pulse chain (CW/CCW) output Clock + Direction signal (CK/Direction) pulse output	1. Open collector output photo-coupler insulation (30 V DC at the maximum, 30 mA resistive load) 2. Line driver output photo-coupler insulation (5 V DC)	
	Maximum leak current	100 μ A	
	Maximum voltage drop at ON	0.8 V at the maximum (at output current 30 mA)	
	Input		
Input	Input voltage	10.8 to 30 V DC	
	Input impedance	Approx. 2.2 k Ω	
	Input current	10 mA (24 V DC) maximum	
	Operating voltage	Minimum ON voltage	9 V
		Maximum OFF voltage	3.6 V
	Input lag	ON \rightarrow OFF	1 ms maximum
		OFF \rightarrow ON	1 ms maximum
	Polarity	Only encoder signal input uses the plus common inside the unit, and other inputs do not specify polarity.	
	Insulation system	Photo-coupler	

A) Specifications of Positioner connector (CN1): conforms to RS-422

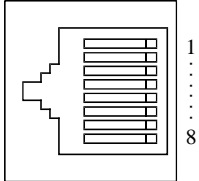
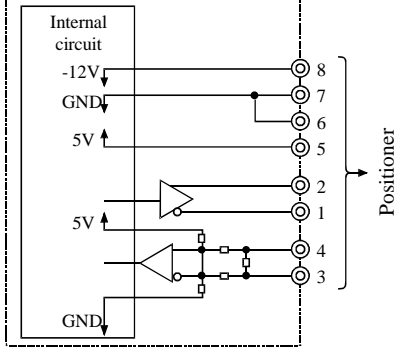
Terminal configuration	No.	Signal	Signal name	Diagram of Internal circuit
	1	Do -	Driver output -	
	2	Do +	Driver output +	
	3	Ri -	Receiver input -	
	4	Ri +	Receiver input +	
	5	5 V DC +	+ 5 V	
	6	0 V	GND	
	7	0 V	GND	
	8	12 V DC -	-12 V	

B) Specifications of I/O connector (CN2)

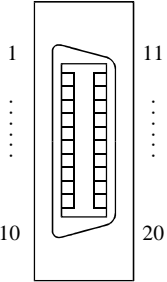
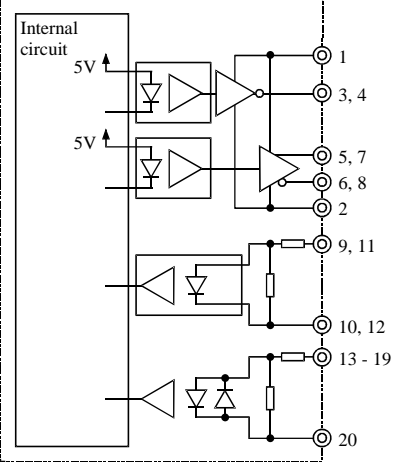
Terminal configuration	No.	Signal	Signal name	Diagram of Internal circuit
	1	5 V DC +	Pulse output power supply	
	2	0 V		
	3	CW	Open collector pulse output	
	4	CCW		
	5	CW +	Line driver pulse output	
	6	CW -		
	7	CCW +		
	8	CCW -		
	9	C +	Encoder C phase	
	10	C -		
	11	PS -	Encoder position signal	
	12	PS +		
	13	COIN	Positioning complete	
	14	PROG	Home position LS	
	15	+ 0.RUN	+ Overrun	
	16	- 0.RUN	- Overrun	
	17	MODE - SEL	Control mode switch	
	18	M - CW	Manual CW	
	19	M - CCW	Manual CCW	
	20	24 V DC +	Control power supply	

2.9.2 High speed counter module : EH-CU/CUE

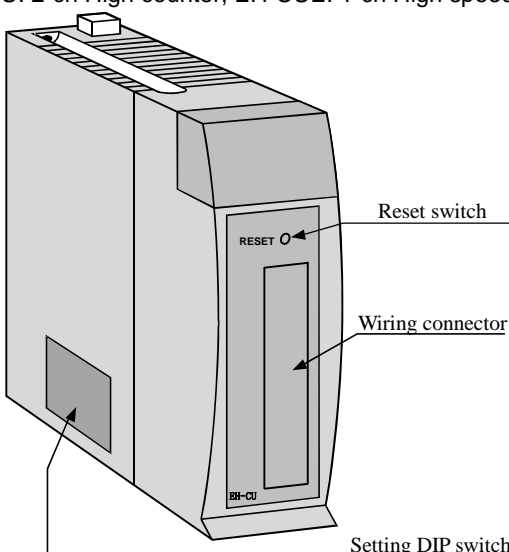
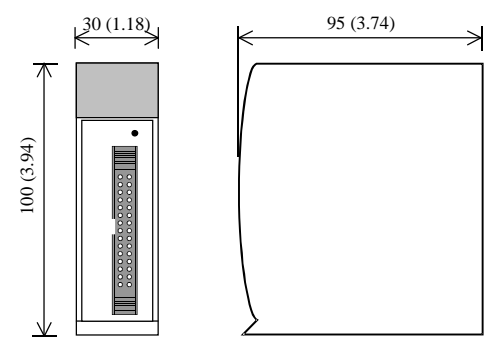

<p>Module features</p> <p>EH-CU: 2-ch High counter, EH-CUE: 1-ch High speed counter</p> 		Type (Weight)	EH-CU (0.16kg (0.35lb.)) EH-CUE (0.16kg (0.35 lb.))
		Dimensions (mm (in.))	
Name	Description		
Reset switch	The module is reset if this switch is pressed.		
Wiring connector	<p>This is a connector with 30 pins (15×2 lines) for connecting the external wiring.</p> <p>(Note) In EH-CU, common to 2 channels</p> <p>Applicable connector on the module side</p> <p>Manufacturer: Hirose Electric Co. Type: HIF3BA-30PA-2.54DS (30 pins male)</p> <p>Applicable connector on the wiring side</p> <p>Manufacturer: Hirose Electric Co. Type: HIF3BA-30D-2.54C (30 pins connector) HIF3-2226SCC (connector pin) HIF3-TB2226HC (crimp tool) HIF3--30CV (connector cover)</p>		
Setting DIP switch	The dip switches are to configure several parameters of EH-CU/E. Be sure to set dip switches while power off.		

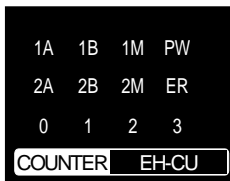
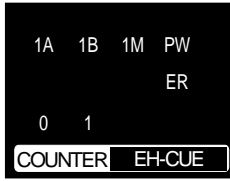
LED name

Front view	LED name	Details	Color
 <p>EH-CU (2-ch type)</p>	PW	Lighted when the power is ON and the module operates regularly.	Green
	ER	Lighted when the hardware error of the module occurs.	Red
	1A	Lighted depending on ON/OFF of the A-phase input signal of Channel 1.	Green
	1B	Lighted depending on ON/OFF of the B-phase input signal of Chnnale1.	Green
	1M	Lighted depending on ON/OFF of the marker input signal of Channel 1.	Green
	2A	Lighted depending on ON/OFF of the A-phase input signal of Channel 2.	Green
	2B	Lighted depending on ON/OFF of the B-phase input signal of Channel 2.	Green
	2M	Lighted depending on ON/OFF of the marker input signal of Channel 2.	Green
	0	Lighted depending on ON/OFF of Y0 output terminal.	Green
	1	Lighted depending on ON/OFF of Y1 output terminal.	Green
 <p>EH-CUE (1-ch type)</p>	2	Lighted depending on ON/OFF of Y2 output terminal.	Green
	3	Lighted depending on ON/OFF of Y3 output terminal.	Green

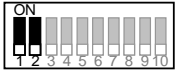
“ER” LED lights up for an instance if the reset switch is pressed down. That is no error.

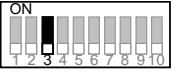
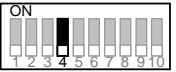
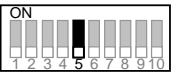
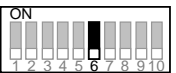
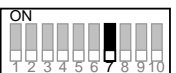
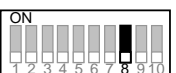
Purpose	Applied switch	Bit1	Bit 2	Explanation
Select the counter mode (Common between channels)	Bit 1-2 	OFF	OFF	2-phase counter (100 kHz at the maximum)
		OFF	ON	1-phase counter (CW, CCW)
		ON	OFF	1-phase counter (CK, UP/DOWN)
		ON	ON	2-phase multiplied by 4 counter (25 kHz at the maximum)

Purpose	Applied switch	Bit1	Bit 2	Explanation
Select the marker polarity	Bit 3 	OFF		Channel 1 Detects the marker at the input OFF edge.
		ON		Channel 1 Detects the marker at the input ON edge.
	Bit 4 	OFF		Channel 2 Detects the marker at the input OFF edge.
		ON		Channel 2 Detects the marker at the input ON edge.
Select counting operation during STOP	Bit 5 	OFF		Channel 1. Stops counting while the CPU module stops.
		ON		Channel 1 Keeps counting while the CPU module stops.
	Bit 6 	OFF		Channel 2 Stops counting while the CPU module stops.
		ON		Channel 2 Keeps counting while the CPU module stops.
Select normal counter/ ring counter	Bit 7 	OFF		Channel 1 Normal counter
		ON		Channel 1 Ring counter
	Bit 8 	OFF		Channel 2 Normal counter
		ON		Channel 2 Ring counter
Select the test mode	Bit 9 	OFF		Normal operation
		ON		Test mode (Program for checking is started up.)

Always use Bit 10 with OFF.

Specifications

Item	Specification		
	EH-CU	EH-CUE	
Type	EH-CU	EH-CUE	
Number of channels	2	1	
Number of counts at the maximum	32 bits (0 to 4,294,967,295)		
Maximum frequency	100 k Hz (25 k Hz at multiplied by 4)		
Count mode	Select by setting of DIP switch. (EH-CU is common to both channels.) 2-phase, 1-phase (CW/CCW, CK, U/D), 2-phase multiplied by 4		
Differential input current	4 mA minimum		
Differential input voltage	12 to 24V DC		
	Minimum ON voltage	10V DC	
	Minimum OFF voltage	4V DC	
Insulation system	Photo-coupler		
Number of input points 3 points / CH	A:A, CW, CK	Phase difference of each channel (A – B) during 2-phase counting +45° to +125° when up, -45° to -125° when down	
	B:B, CCW, U/D		
	M: Marker (z)		
Minimum counter pulse width	ON: 4 μs, OFF: 4 μs		
Minimum marker pulse width	10 μs (detected at ON edge)		
External wiring method	30-pin connector		
External wiring	Wired with twisted pair cables and batch shielded cables		
Output voltage	12/24 V DC (30 V DC at the maximum)		
Load current	20 mA / point at the maximum		
Output method	Open collector output		
Minimum load current	1 mA		
Output delay time	ON → OFF	1 ms maximum	
	OFF → ON	1 ms maximum	
Voltage down at ON	1.5 V at the maximum		
Number of external output points	4	2	
	Normal counter	Current value = Set value 1, or Current value > Set value 1	
	Ring counter	Current value = Set value 2	
Leak current	0.5 mA at the maximum		
Polarity	(-) common within the module		
External power supply	12/24 V DC (30 V DC at the maximum)		
Insulation system	Photo-coupler		
Internal current consumption	310mA maximum		

Specifications of I/O terminal

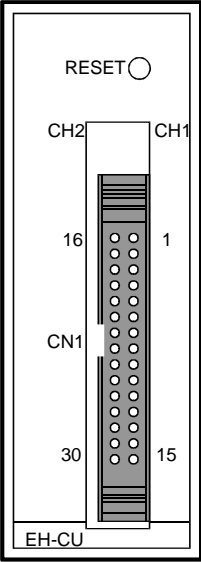
EH-CU	Terminal configuration	No.	CH2	No.	CH1	Meaning of signal		
		16	Vin A	1	Vin A	Phase A	Connects to a 12 to 24V DC power supply at using voltage input.	
		17	A (+)	2	A (+)		Connects (+) polarity at using differential input.	
		18	A (-)	3	A (-)		Connects an open collector signal at using voltage input. Connects (-) polarity at using differential input.	
		19	Vin B	4	Vin B	Phase B	Connects a 12 to 24V DC power supply at using voltage input.	
		20	B (+)	5	B (+)		Connects (+) polarity at using differential input.	
		21	B (-)	6	B (-)		Connects an open collector signal at using voltage input. Connects (-) polarity at using differential input.	
		22	Vin M	7	Vin M	Marker	Connects a 12 to 24V DC power supply at using voltage input.	
		23	M (+)	8	M (+)		Connects (+) polarity at using differential input.	
		24	M (-)	9	M (-)		Connects an open collector signal at using voltage input. Connects (-) polarity at using differential input.	
			25 to 27 N.C.		10 to 12 N.C.			Connect nothing.
			28	Y2	13	Y0	Output	Coincidence output. Connects to the other input.
			29	Y3	14	Y1		Coincidence output. Connects to the other input.
			30	Com2	15	Com1		(-) common for coincidence common. Commons 1 and 2 are independent.

Note: Pin No. defined in EH-CU does not accord with pin No. defined by connector maker.

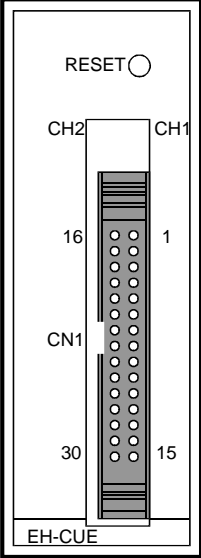
EH-CUE	Terminal configuration	No.	CH2	No.	CH1	Meaning of signal	
	16	N.C.	1	Vin A	Phase A	Connects to a 12 to 24V DC power supply at using voltage input.	
	17	N.C.	2	A (+)		Connects (+) polarity at using differential input.	
	18	N.C.	3	A (-)		Connects an open collector signal at using voltage input. Connects (-) polarity at using differential input.	
	19	N.C.	4	Vin B	Phase B	Connects to a 12 to 24V DC power supply at using voltage input.	
	20	N.C.	5	B (+)		Connects (+) polarity at using differential input.	
	21	N.C.	6	B (-)		Connects an open collector signal at using voltage input. Connects (-) polarity at using differential input.	
	22	N.C.	7	Vin M	Marker	Connects to a 12 to 24V DC power supply at using voltage input.	
	23	N.C.	8	M (+)		Connects (+) polarity at using differential input.	
	24	N.C.	9	M (-)		Connects an open collector signal at using voltage input. Connects (-) polarity at using differential input.	
	25 to 27 N.C.		10 to 12 N.C.		Connect nothing.		
	28	N.C.	13	Y0	Output	Coincidence output. Connects to the other input.	
	29	N.C.	14	Y1		Coincidence output. Connects to the other input.	
	30	N.C.	15	Com1		(-) common for coincidence output	

Note: Pin No. defined in EH-CUE does not accord with pin No. defined by the connector maker.

2.9.3 Serial interface module : EH-SIO

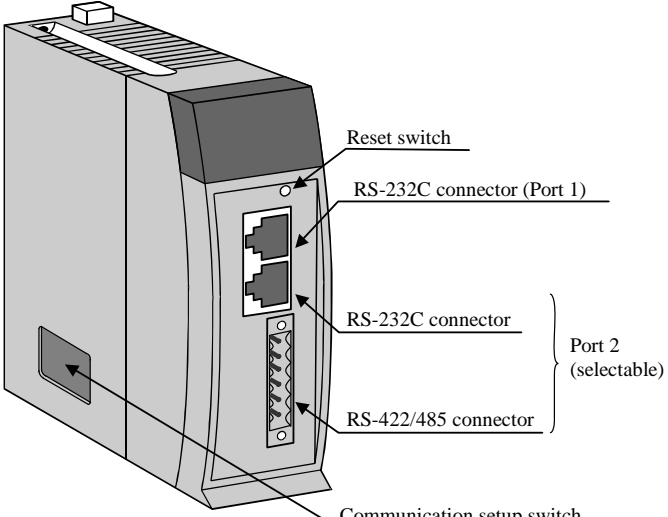
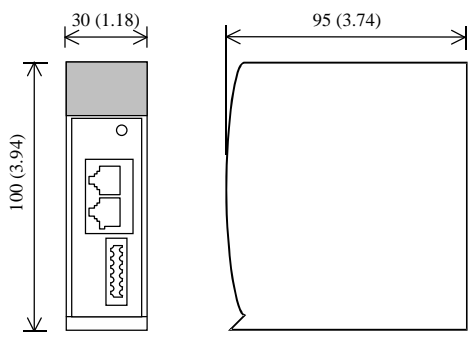
		Type (Weight)	EH-SIO (Approx. 0.13kg (0.29lb.))
		Dimensions (mm (in.))	
Name		Description	
Reset switch		The module is reset if this switch is pressed.	
Port 1	RS-232C port	Connects a transmission channel of RS-232C.	
Port 2	RS-232C port	Connects a transmission channel of RS-232C.	
	RS-422 / 485 port	Connects a transmission channel of RS-422 / 485.	
Communication setup switch		Sets specifications of communication with external devices. Set the module correctly after confirming the specification of communication of the external device. Turn off the power supply and remove the module from the base to set it.	

LED display

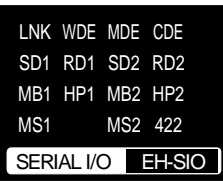
Front view	Name	Details	Color
	LNK	Lights up in the simple data link mode.	Green
	WDE	Lights up when microcomputer error (serious error) occurs. (Common to port 1 / port 2)	Red
	MDE	Lights up when module error (serious error) occurs. (Common to port 1 / port 2)	Red
	CDE	Lights up when error (warning) such as command error occurs. (Common to port 1 / port 2)	Red
	SD1	Flashes while data is transmitted from port 1.	Green
	RD1	Flashes while port 1 receives data.	Green
	MB1	Lights up when Modbus-RTU is set in port 1.	Green
	HP1	Lights up when H-protocol is set in port 1 (not available with EHV+).	Green
	MS1	Lights up when Modbus-RTU master is set in port1.	Green
	SD2	Flashes while data is transmitted from port 2	Green
	RD2	Flashes while port 2 receives data.	Green
	MB2	Lights up when Modbus-RTU is set in port 2.	Green
	HP2	Lights up when H-protocol is set in port 2 (not available with EHV+).	Green
	MS2	Lights up when Modbus-RTU master is set in port2.	Green
	422	Lights up when RS-422/485 is set in port 2.	Green

Communication setup switch

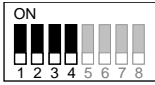
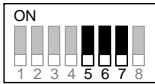
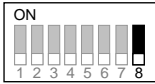
Setting	Details																																																																																					
<p>Communication speed setup</p> <ul style="list-style-type: none"> - DIP Sw1 is for port 1 setup - DIP Sw2 is for port 2 setup 	<p>Bit 1, 2, 3, and 4 are used for the communication speed setting.</p>  <table border="1"> <thead> <tr> <th>Bit1</th> <th>Bit2</th> <th>Bit3</th> <th>Bit4</th> <th>Communication speed</th> </tr> </thead> <tbody> <tr><td>OFF</td><td>OFF</td><td>OFF</td><td>OFF</td><td>Do not set these patterns.</td></tr> <tr><td>OFF</td><td>OFF</td><td>OFF</td><td>ON</td><td></td></tr> <tr><td>OFF</td><td>OFF</td><td>ON</td><td>OFF</td><td></td></tr> <tr><td>OFF</td><td>OFF</td><td>ON</td><td>ON</td><td>1,200 bps</td></tr> <tr><td>OFF</td><td>ON</td><td>OFF</td><td>OFF</td><td>2,400 bps</td></tr> <tr><td>OFF</td><td>ON</td><td>OFF</td><td>ON</td><td>4,800 bps</td></tr> <tr><td>OFF</td><td>ON</td><td>ON</td><td>OFF</td><td>9,600 bps</td></tr> <tr><td>OFF</td><td>ON</td><td>ON</td><td>ON</td><td>19,200 bps</td></tr> <tr><td>ON</td><td>OFF</td><td>OFF</td><td>OFF</td><td>38,400 bps</td></tr> <tr><td>ON</td><td>OFF</td><td>OFF</td><td>ON</td><td>57,600 bps</td></tr> <tr><td>ON</td><td>OFF</td><td>ON</td><td>OFF</td><td>Do not set these patterns.</td></tr> <tr><td>ON</td><td>OFF</td><td>ON</td><td>ON</td><td></td></tr> <tr><td>ON</td><td>ON</td><td>OFF</td><td>OFF</td><td></td></tr> <tr><td>ON</td><td>ON</td><td>OFF</td><td>ON</td><td></td></tr> <tr><td>ON</td><td>ON</td><td>ON</td><td>OFF</td><td></td></tr> <tr><td>ON</td><td>ON</td><td>ON</td><td>ON</td><td></td></tr> </tbody> </table>	Bit1	Bit2	Bit3	Bit4	Communication speed	OFF	OFF	OFF	OFF	Do not set these patterns.	OFF	OFF	OFF	ON		OFF	OFF	ON	OFF		OFF	OFF	ON	ON	1,200 bps	OFF	ON	OFF	OFF	2,400 bps	OFF	ON	OFF	ON	4,800 bps	OFF	ON	ON	OFF	9,600 bps	OFF	ON	ON	ON	19,200 bps	ON	OFF	OFF	OFF	38,400 bps	ON	OFF	OFF	ON	57,600 bps	ON	OFF	ON	OFF	Do not set these patterns.	ON	OFF	ON	ON		ON	ON	OFF	OFF		ON	ON	OFF	ON		ON	ON	ON	OFF		ON	ON	ON	ON	
Bit1	Bit2	Bit3	Bit4	Communication speed																																																																																		
OFF	OFF	OFF	OFF	Do not set these patterns.																																																																																		
OFF	OFF	OFF	ON																																																																																			
OFF	OFF	ON	OFF																																																																																			
OFF	OFF	ON	ON	1,200 bps																																																																																		
OFF	ON	OFF	OFF	2,400 bps																																																																																		
OFF	ON	OFF	ON	4,800 bps																																																																																		
OFF	ON	ON	OFF	9,600 bps																																																																																		
OFF	ON	ON	ON	19,200 bps																																																																																		
ON	OFF	OFF	OFF	38,400 bps																																																																																		
ON	OFF	OFF	ON	57,600 bps																																																																																		
ON	OFF	ON	OFF	Do not set these patterns.																																																																																		
ON	OFF	ON	ON																																																																																			
ON	ON	OFF	OFF																																																																																			
ON	ON	OFF	ON																																																																																			
ON	ON	ON	OFF																																																																																			
ON	ON	ON	ON																																																																																			
<p>Transmission letter configuration setup</p> <ul style="list-style-type: none"> - DIP Sw1 is for port 1 setup. - DIP Sw2 is for port 2 setup. 	<p>Bit 5, 6, and 7 are used for the transmission letter configuration setup.</p>  <table border="1"> <thead> <tr> <th rowspan="2">Bit5</th> <th rowspan="2">Bit6</th> <th rowspan="2">Bit7</th> <th colspan="3">Communication format setup</th> </tr> <tr> <th>Data length</th> <th>Stop bit</th> <th>Type of parity</th> </tr> </thead> <tbody> <tr><td>OFF</td><td>OFF</td><td>OFF</td><td>7</td><td>2</td><td>Even number</td></tr> <tr><td>OFF</td><td>OFF</td><td>ON</td><td>7</td><td>2</td><td>Odd number</td></tr> <tr><td>OFF</td><td>ON</td><td>OFF</td><td>7</td><td>1</td><td>Even number</td></tr> <tr><td>OFF</td><td>ON</td><td>ON</td><td>7</td><td>1</td><td>Odd number</td></tr> <tr><td>ON</td><td>OFF</td><td>OFF</td><td>8</td><td>2</td><td>None</td></tr> <tr><td>ON</td><td>OFF</td><td>ON</td><td>8</td><td>1</td><td>None</td></tr> <tr><td>ON</td><td>ON</td><td>OFF</td><td>8</td><td>1</td><td>Even number</td></tr> <tr><td>ON</td><td>ON</td><td>ON</td><td>8</td><td>1</td><td>Odd number</td></tr> </tbody> </table>	Bit5	Bit6	Bit7	Communication format setup			Data length	Stop bit	Type of parity	OFF	OFF	OFF	7	2	Even number	OFF	OFF	ON	7	2	Odd number	OFF	ON	OFF	7	1	Even number	OFF	ON	ON	7	1	Odd number	ON	OFF	OFF	8	2	None	ON	OFF	ON	8	1	None	ON	ON	OFF	8	1	Even number	ON	ON	ON	8	1	Odd number																												
Bit5	Bit6				Bit7	Communication format setup																																																																																
		Data length	Stop bit	Type of parity																																																																																		
OFF	OFF	OFF	7	2	Even number																																																																																	
OFF	OFF	ON	7	2	Odd number																																																																																	
OFF	ON	OFF	7	1	Even number																																																																																	
OFF	ON	ON	7	1	Odd number																																																																																	
ON	OFF	OFF	8	2	None																																																																																	
ON	OFF	ON	8	1	None																																																																																	
ON	ON	OFF	8	1	Even number																																																																																	
ON	ON	ON	8	1	Odd number																																																																																	
<p>Select of I/F of port 2 communication (Only DIP Sw2)</p>	<p>Bit 8 is used for selecting I/F of port 2 (RS-232C or RS-422 / 485) (RS-422 / 485 is decided according to external wiring.)</p>  <table border="1"> <thead> <tr> <th>Bit8</th> <th>Select I/F of Port 2 communication</th> </tr> </thead> <tbody> <tr><td>OFF</td><td>RS-232C port</td></tr> <tr><td>ON</td><td>RS-422 / RS-485 port</td></tr> </tbody> </table>	Bit8	Select I/F of Port 2 communication	OFF	RS-232C port	ON	RS-422 / RS-485 port																																																																															
Bit8	Select I/F of Port 2 communication																																																																																					
OFF	RS-232C port																																																																																					
ON	RS-422 / RS-485 port																																																																																					

[Note] The system uses DIP Sw1(Bit8). Do not turn on it.

RS-232C connector

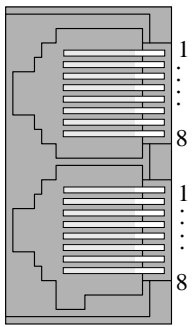
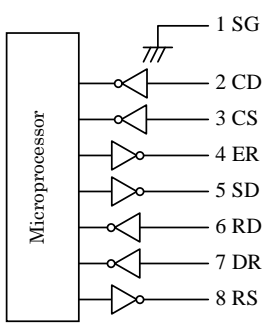
External view of connector	No.	Signal	Signal name	Diagram of Internal circuit
	1	SG	Signal grounding	
	2	CD	Career detection	
	3	CS	Transmittable	
	4	ER	Data terminal ready	
	5	SD	EH-SIO transmitting data	
	6	RD	EH-SIO receiving data	
	7	DR	Data set ready	
	8	RS	Transmitting request	

RS-422 / 485 connector

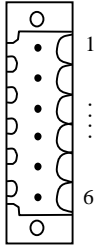
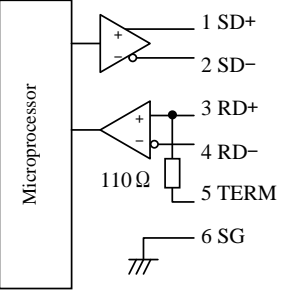
External view of connector	No.	Signal	Signal name	Diagram of Internal circuit
	1	SD+	EH-SIO transmitting data +	
	2	SD-	EH-SIO transmitting data -	
	3	RD+	EH-SIO receiving data +	
	4	RD-	EH-SIO receiving data -	
	5	TERM	For terminator	
	6	SG	Signal grounding	

Functional specifications

Item	Specification
Mounting position	Basic base and Expansion base (cannot mount on Remote base)
The number of units to be mounted	Unlimited within the range of power supply capacity of the power module.
Supporting communication mode	No protocol (General purpose communication), Modbus master (RTU)

Communication specifications

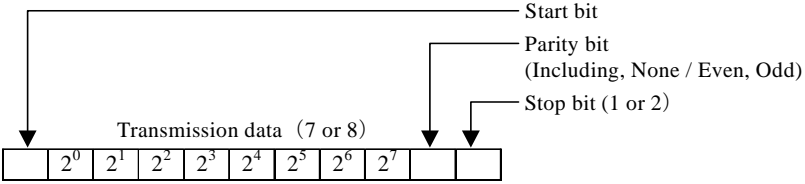
Item	Specification	
Interface	Port 1	RS-232C
	Port 2	RS-232C or RS-422/485
Transmission speed	Selectable from 4,800 / 9,600 / 19,200 / 38,400 / 57,600 bps	
Transmission system	Bit serial system (Transmitted from the lowest bit of transmission signal)	
Synchronization	Asynchronous	
Transmission character configuration	 <p>The diagram illustrates the bit sequence for a transmission character. It starts with a Start bit, followed by 7 or 8 bits of transmission data labeled 2^0 through 2^7. This is followed by a Parity bit (which can be None, Even, or Odd) and a Stop bit (which can be 1 or 2 bits long).</p>	
Input buffer	1,024 bytes / port	
Output buffer	1,024 bytes / port	
Error control	Overrun error, framing error, parity error, input buffer full, message error, timeout error	
RS-232C port	Connection mode	1 : 1
	Transmission distance	15 m (49.37ft.) (Maximum)
	Connector	RJ-45 connector
RS-422 / 485 port	Connection mode	1 : N (N : 32 units at the maximum)
	Transmission distance	500 m (548.61yd.) (Maximum)
	Connector	Attached with the module (BL3.5/6F by Weidmuller)

2.9.4 PROFIBUS-DP module

(1) Profibus-DP master module : EH-RMP/2

Module features	Type (Weight)	EH-RMP (Approx. 0.13kg (0.28lb.))
	Dimensions (mm (in.))	

Name	Description																	
Connector 1	Connect to PC (configurator), 9pin male Sub-D Be careful, this connector become hot.																	
Reset switch	When module is abnormal, module is reset by pushing this.																	
DIP switch *1 (No. 1,2 not used)	<table border="1"> <thead> <tr> <th colspan="2">Switch No.</th> <th rowspan="2">Supplementary explanation (when the CPU is stopped)</th> </tr> <tr> <th>4</th> <th>3</th> </tr> </thead> <tbody> <tr> <td>OFF</td> <td>OFF</td> <td>CLEAR mode: the output data is cleared.</td> </tr> <tr> <td>OFF</td> <td>ON</td> <td>FREEZE mode: the output data is frozen.</td> </tr> <tr> <td>ON</td> <td>OFF</td> <td>COPY mode: the output data is copied from the CPU.</td> </tr> <tr> <td>ON</td> <td>ON</td> <td>Not use</td> </tr> </tbody> </table>	Switch No.		Supplementary explanation (when the CPU is stopped)	4	3	OFF	OFF	CLEAR mode: the output data is cleared.	OFF	ON	FREEZE mode: the output data is frozen.	ON	OFF	COPY mode: the output data is copied from the CPU.	ON	ON	Not use
	Switch No.		Supplementary explanation (when the CPU is stopped)															
	4	3																
	OFF	OFF	CLEAR mode: the output data is cleared.															
	OFF	ON	FREEZE mode: the output data is frozen.															
ON	OFF	COPY mode: the output data is copied from the CPU.																
ON	ON	Not use																
Termination switch	ON: bus termination enabled OFF: bus termination disabled																	
Connector 2	Connect to field bus, 9pin female Sub-D The screw is the terminal for functional earth.																	

*1: For setting of this switch, remove the module from the rack. If the setting ends, cover with the protection sheet.

LED display

Front view	LED name	Description	Color
	STATUS	The state of the EH-RMP	Green
	RUN	Communication running	Green
	ERR	Error on communication line	Red
	RDY	Device has no error	Green
	TOKEN	Lit all the time	Green

Module features		Type (weight)	EH-RMP2 (Approx. 0.16kg (0.35lb))
		Dimensions (mm (in.))	
No.	Name	Function	Remarks
1]	Lock button	Press this button to dismount. Module can be fixed firmly by a screw of M4 × 10mm (0.39in).	
2]	Communication connector	D-sub 9-pin connector for communication cable.	
3]	USB communication connector	Type-B USB connector for configuration.	
4]	LED display	The status of module is displayed on this LED.	
5]	Rotary switch	This is a rotary switch to set network input / output sizes.	
6]	Reset switch	The module can be reset by pressing this switch when the module detected an error. At the time the RDYLED is turned off immediately after the press, it will be reset.	Please do not press and hold the reset switch.
7]	Side DIP switch	This is a switch to set an operation mode.	

Connector

Connector	Symbol	Indication	Details																				
	PROFIBUS	Communication connector	<p>D-sub 9 pin connector.</p> <p>Terminal layouts are shown below.</p> <table border="1"> <thead> <tr> <th>Pin No.</th> <th>Details</th> </tr> </thead> <tbody> <tr><td>1</td><td>NC</td></tr> <tr><td>2</td><td>NC</td></tr> <tr><td>3</td><td>B-Line</td></tr> <tr><td>4</td><td>NC</td></tr> <tr><td>5</td><td>GND</td></tr> <tr><td>6</td><td>+5 V DC</td></tr> <tr><td>7</td><td>NC</td></tr> <tr><td>8</td><td>A-Line</td></tr> <tr><td>9</td><td>NC</td></tr> </tbody> </table>	Pin No.	Details	1	NC	2	NC	3	B-Line	4	NC	5	GND	6	+5 V DC	7	NC	8	A-Line	9	NC
Pin No.	Details																						
1	NC																						
2	NC																						
3	B-Line																						
4	NC																						
5	GND																						
6	+5 V DC																						
7	NC																						
8	A-Line																						
9	NC																						

LED display

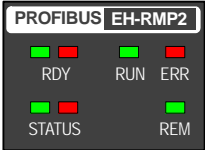
LED	LED name	Indication	Details																			
	RDY	Hardware status (Green / Red)	Display EH-RMP2 hardware status. <table border="1"> <thead> <tr> <th>State</th> <th>Details</th> </tr> </thead> <tbody> <tr> <td>Off</td> <td>Hardware error Power supply error</td> </tr> <tr> <td>Flash in green or red</td> <td>Initialization</td> </tr> <tr> <td>Lit in red</td> <td>Hardware error</td> </tr> <tr> <td>Lit in green</td> <td>No error</td> </tr> </tbody> </table>	State	Details	Off	Hardware error Power supply error	Flash in green or red	Initialization	Lit in red	Hardware error	Lit in green	No error									
	State	Details																				
	Off	Hardware error Power supply error																				
	Flash in green or red	Initialization																				
	Lit in red	Hardware error																				
Lit in green	No error																					
STATUS	System status (Green / Red)	Display the EH-RMP2 system status. <table border="1"> <thead> <tr> <th>State</th> <th>Details</th> </tr> </thead> <tbody> <tr> <td>Off</td> <td>Power supply error</td> </tr> <tr> <td>Flash in red</td> <td>Internal error</td> </tr> <tr> <td>Lit in red</td> <td>WDT error</td> </tr> <tr> <td>Fifth-flash in green</td> <td>Side DIP switch setting error</td> </tr> <tr> <td>Forth-flash in green</td> <td>Link parameter error</td> </tr> <tr> <td>Triple-flash in green</td> <td>Configuration data error</td> </tr> <tr> <td>Double-flash in green</td> <td>CPU module error</td> </tr> <tr> <td>Single-flash in green</td> <td>Initialization</td> </tr> <tr> <td>Lit in green</td> <td>No error</td> </tr> </tbody> </table>	State	Details	Off	Power supply error	Flash in red	Internal error	Lit in red	WDT error	Fifth-flash in green	Side DIP switch setting error	Forth-flash in green	Link parameter error	Triple-flash in green	Configuration data error	Double-flash in green	CPU module error	Single-flash in green	Initialization	Lit in green	No error
State	Details																					
Off	Power supply error																					
Flash in red	Internal error																					
Lit in red	WDT error																					
Fifth-flash in green	Side DIP switch setting error																					
Forth-flash in green	Link parameter error																					
Triple-flash in green	Configuration data error																					
Double-flash in green	CPU module error																					
Single-flash in green	Initialization																					
Lit in green	No error																					
RUN	Network status (Green)	Display PROFIBUS network status. <table border="1"> <thead> <tr> <th>State</th> <th>Details</th> </tr> </thead> <tbody> <tr> <td>Off</td> <td>No communication established</td> </tr> <tr> <td>Blinking</td> <td>Under communication establishment</td> </tr> <tr> <td>On</td> <td>Communication established</td> </tr> </tbody> </table>	State	Details	Off	No communication established	Blinking	Under communication establishment	On	Communication established												
State	Details																					
Off	No communication established																					
Blinking	Under communication establishment																					
On	Communication established																					
ERR	Error status (Red)	Display PROFIBUS error status. <table border="1"> <thead> <tr> <th>State</th> <th>Details</th> </tr> </thead> <tbody> <tr> <td>Off</td> <td>No error</td> </tr> <tr> <td>Blinking</td> <td>Slave units at least one are not established.</td> </tr> <tr> <td>On*1</td> <td>All slave units are not established</td> </tr> </tbody> </table>	State	Details	Off	No error	Blinking	Slave units at least one are not established.	On*1	All slave units are not established												
State	Details																					
Off	No error																					
Blinking	Slave units at least one are not established.																					
On*1	All slave units are not established																					
REM	Operating mode (Green)	No use. It is always off.																				



In establishing all slave units, Error status LED is lighting for a moment but it is no problem.

The state of LED is indicated below.

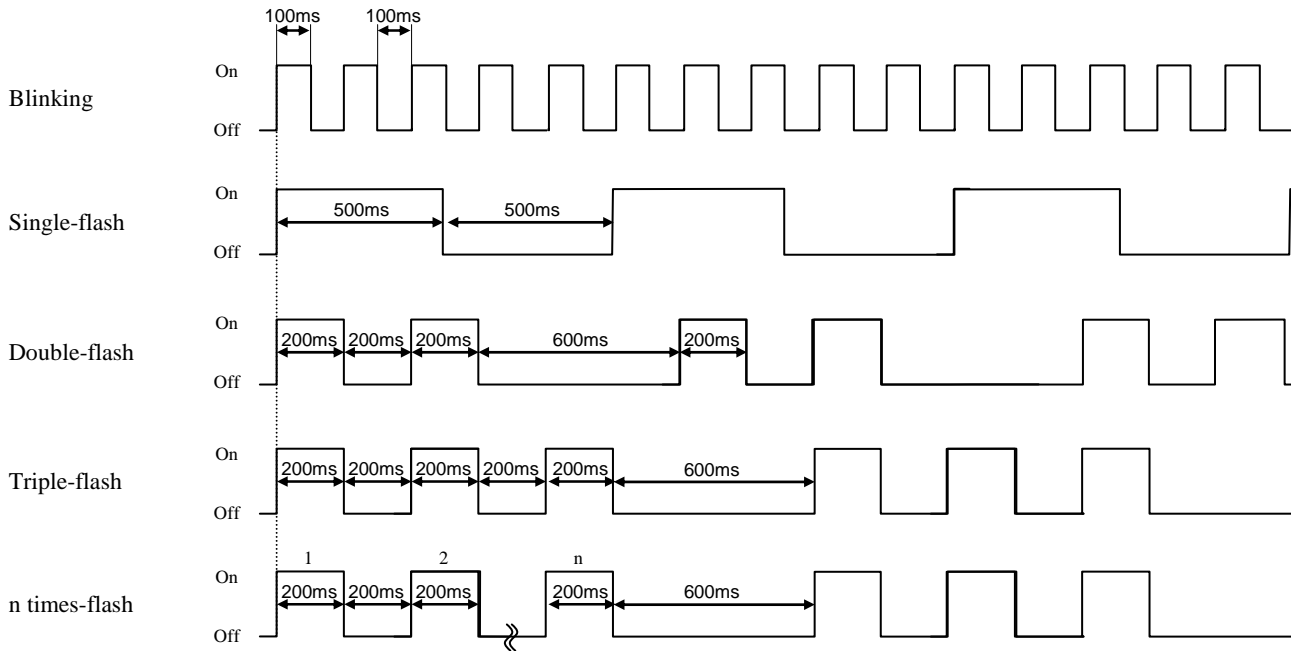



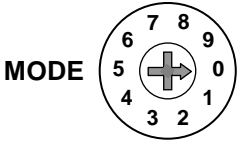





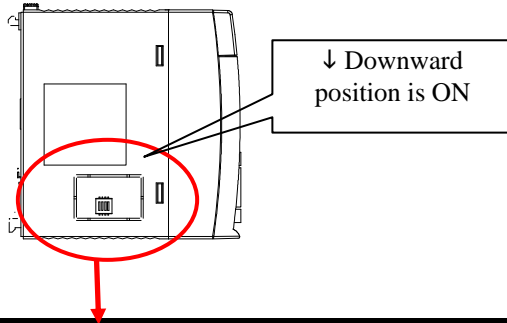







Rotary switch

Rotary switch	Symbol	Meaning	Details of setting			
 <p>MODE</p> <p>[Default setting: 0]</p>	MODE	Input / Output Sizes	The input / output sizes of PROFIBUS network is set by rotary switch.			
			Value	Network size	Input size	Output size
			0	Variable size	512 words max	512 words max
			1	64W / 64W fixed	64 words	64 words
			2	128W / 128W fixed	128 words	128 words
			3	256W / 256W fixed	256 words	256 words
			4	512W / 512W fixed	512 words	512 words
			5	Variable size	512 words max	512 words max
			6			
			7			
8						
9						

Please set rotary switch to 0 if you use auto addressing function with use of the SYCON.net. If you map each slave I/O address including offset address, please set rotary switch value 1, 2, 3 or 4. When actual input / output sizes exceed setting sizes, EH-RMP2 detects error.

Side DIP switch



No.	Setting description	Details																				
1	No use  [Default setting: OFF]	Please keep off.																				
2	No use  [Default setting: OFF]	Please keep off.																				
3,4	Output hold selecting  [Default setting: OFF]	When the CPU is switched from RUN to STOP position, it can select output status. <table border="1" data-bbox="454 907 1452 1377"> <thead> <tr> <th>Bit4</th> <th>Bit3</th> <th>Position</th> <th>Output hold function selection</th> </tr> </thead> <tbody> <tr> <td>OFF</td> <td>OFF</td> <td></td> <td>Clear mode. When the CPU is switched from RUN to STOP position, EH-RMP2 outputs the zero data to PROFIBUS. But the link area (WL) is not cleared.</td> </tr> <tr> <td>OFF</td> <td>ON</td> <td></td> <td>Freeze mode. When the CPU is switched from RUN to STOP position, EH-RMP2 holds output data that is last data received.</td> </tr> <tr> <td>ON</td> <td>OFF</td> <td></td> <td>Copy mode. When the CPU is switched from RUN to STOP position, EH-RMP2 continues to copy in the link area. When using EH-CPU316A, this mode is effective in case that EH-CPU316A ROM version is 02 or higher.</td> </tr> <tr> <td>ON</td> <td>ON</td> <td></td> <td>Don't care.</td> </tr> </tbody> </table>	Bit4	Bit3	Position	Output hold function selection	OFF	OFF		Clear mode. When the CPU is switched from RUN to STOP position, EH-RMP2 outputs the zero data to PROFIBUS. But the link area (WL) is not cleared.	OFF	ON		Freeze mode. When the CPU is switched from RUN to STOP position, EH-RMP2 holds output data that is last data received.	ON	OFF		Copy mode. When the CPU is switched from RUN to STOP position, EH-RMP2 continues to copy in the link area. When using EH-CPU316A, this mode is effective in case that EH-CPU316A ROM version is 02 or higher.	ON	ON		Don't care.
Bit4	Bit3	Position	Output hold function selection																			
OFF	OFF		Clear mode. When the CPU is switched from RUN to STOP position, EH-RMP2 outputs the zero data to PROFIBUS. But the link area (WL) is not cleared.																			
OFF	ON		Freeze mode. When the CPU is switched from RUN to STOP position, EH-RMP2 holds output data that is last data received.																			
ON	OFF		Copy mode. When the CPU is switched from RUN to STOP position, EH-RMP2 continues to copy in the link area. When using EH-CPU316A, this mode is effective in case that EH-CPU316A ROM version is 02 or higher.																			
ON	ON		Don't care.																			

Specifications

Item	Specifications	
	EH-RMP2	EH-RMP
Communication protocol	PROFIBUS-DP V0	
Range of node address	0 to 125: Setting by configuration tool	
Maximum I/O size	Input: 512 words, output: 512 words (Setting by rotary switch)	Input: 256 words, output: 256 words
Connector	D-sub 9 pin	
Topology	BUS	
Communication cable	PROFIBUS cable	
Segment length, Transmit speed	9.6 kbps : 1,200 m 19.2 kbps : 1,200 m 93.75 kbps : 1,200 m 187.5 kbps : 1,000 m 500 kbps : 400 m 1500 kbps : 200 m 3 Mbps : 100 m 6 Mbps : 100 m 12 Mbps : 100 m	
Maximum connectable number of slaves	125 slaves	
Output hold	Supported (Clear mode, Freeze mode, Copy mode)	
Termination	Not built-in	Built-in
Configuration tool	SYCON.net	SyCon
Self-check	WDT check	WDT check System memory check
Error indication	LED	
Current consumption	780 mA	600 mA
Standard compliant	CE, C-Tick*1	UL, CE, C-Tick

*1 UL is not supported. Contact your local supplier for further information.

(2) Profibus-DP Slave controller : EH-IOCP/2

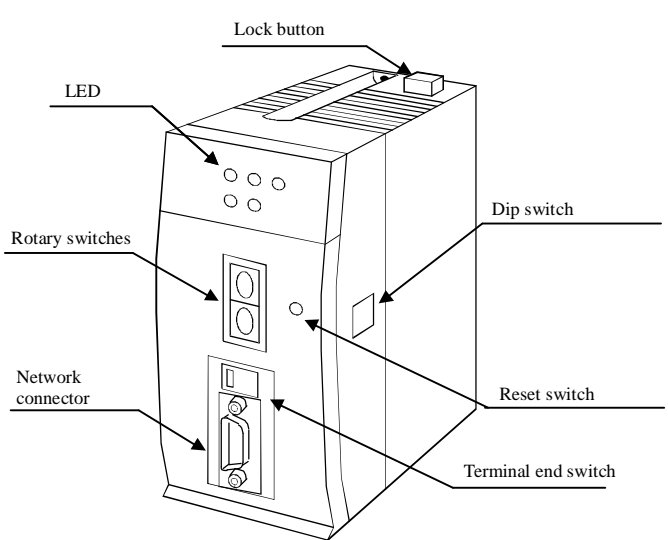
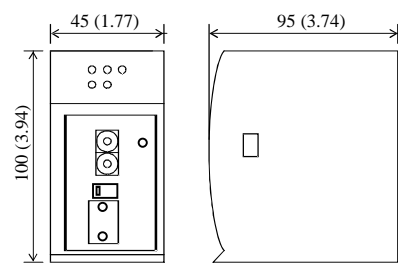
<p>Module features</p> 	<p>Type (Weight)</p>	<p>EH-IOCP (Approx. 0.16kg (0.35lb.))</p>
	<p>Dimensions (mm(in.))</p>	

Name	Function	Remarks
Lock button	When dismantling the module from a base unit, press this button and lift up the module. The module can be fixed firmly by a screw (M4, 10 mm (0.39 in.)).	
LED	Displays the communication and other statuses of the module.	
Rotary switches	Sets the node address.	
Network connector	D-sub 9-pin female	Surface of the connector is hot while operation. Be careful to handle.
Dip switch	Specifies the output data for the output module when the network is abnormal.	
Reset switch	Resets the unit when the module is malfunctioning.	
Terminal end switch	Turns on when this module is at the end of a network.	

Functional specifications

Item	Specification																				
No. of installed I/O modules	16 units/EH-IOCP (use EH-IOCH2 to install more than 11 units.)																				
Node address setting range	1 to 99																				
Input/output capacity	208 words																				
Data update time	5 ms																				
Transmission speed: Segment length	<table style="width: 100%; border: none;"> <tr> <td style="width: 25%;">9.6 kbps</td> <td style="width: 25%;">1,200 m</td> <td style="width: 25%;">1,500 kbps</td> <td style="width: 25%;">200 m</td> </tr> <tr> <td>19.2 kbps</td> <td>1,200 m</td> <td>3 Mbps</td> <td>100 m</td> </tr> <tr> <td>93.75 kbps</td> <td>1,200 m</td> <td>6 Mbps</td> <td>100 m</td> </tr> <tr> <td>187.5 kbps</td> <td>1,000 m</td> <td>12 Mbps</td> <td>100 m</td> </tr> <tr> <td>500 kbps</td> <td>400 m</td> <td></td> <td></td> </tr> </table>	9.6 kbps	1,200 m	1,500 kbps	200 m	19.2 kbps	1,200 m	3 Mbps	100 m	93.75 kbps	1,200 m	6 Mbps	100 m	187.5 kbps	1,000 m	12 Mbps	100 m	500 kbps	400 m		
9.6 kbps	1,200 m	1,500 kbps	200 m																		
19.2 kbps	1,200 m	3 Mbps	100 m																		
93.75 kbps	1,200 m	6 Mbps	100 m																		
187.5 kbps	1,000 m	12 Mbps	100 m																		
500 kbps	400 m																				
Self-diagnostics	System ROM/RAM check, Watchdog timer																				
GSD file	File name: Hita 049.gsd																				
Internal current consumption	600mA maximum																				

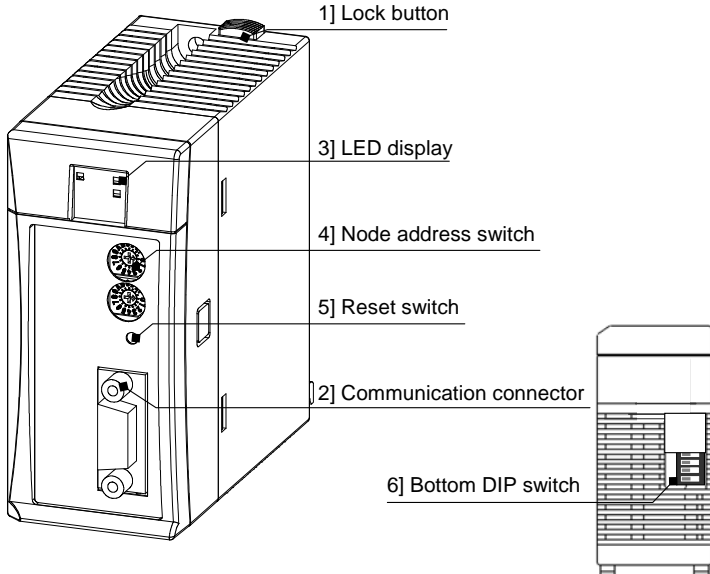
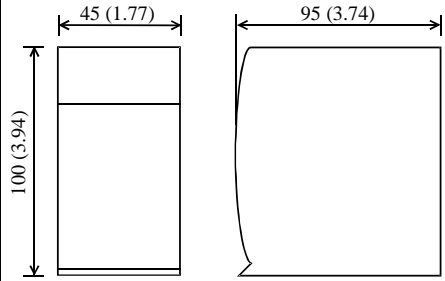
Module features		Type (weight)	EH-IOCP2 (0.14kg (0.31lb))
		Dimensions (mm (in.))	
No.	Name	Function	Remarks
1]	Lock button	Press this button to dismount. Module can be fixed firmly by a screw of M4 × 10mm (0.39in).	
2]	Communication connector	D-sub 9-pin connector for communication cable.	
3]	LED display	The status of module is displayed on this LED.	
4]	Node address switch	This is a switch to set the node address.	
5]	Reset switch	The module can be reset by pressing this switch when the module detected an error.	
6]	Bottom DIP switch	This is a switch to set an operation mode (the output hold, etc.).	

Connector

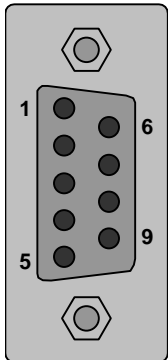
Connector	Symbol	Indication	Details																				
	PROFIBUS	Communication connector	<p>D-sub 9 pin connector.</p> <p>Terminal layouts are shown below.</p> <table border="1"> <thead> <tr> <th>Pin No.</th> <th>Details</th> </tr> </thead> <tbody> <tr> <td>1</td> <td>NC</td> </tr> <tr> <td>2</td> <td>NC</td> </tr> <tr> <td>3</td> <td>B-Line</td> </tr> <tr> <td>4</td> <td>NC</td> </tr> <tr> <td>5</td> <td>GND</td> </tr> <tr> <td>6</td> <td>+5 V DC</td> </tr> <tr> <td>7</td> <td>NC</td> </tr> <tr> <td>8</td> <td>A-Line</td> </tr> <tr> <td>9</td> <td>NC</td> </tr> </tbody> </table>	Pin No.	Details	1	NC	2	NC	3	B-Line	4	NC	5	GND	6	+5 V DC	7	NC	8	A-Line	9	NC
Pin No.	Details																						
1	NC																						
2	NC																						
3	B-Line																						
4	NC																						
5	GND																						
6	+5 V DC																						
7	NC																						
8	A-Line																						
9	NC																						

LED display

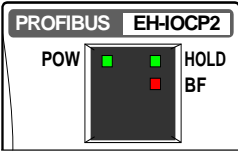
LED	LED name	Indication	Details													
	POW	Power supply (Green)	On : indicates that the DC5V power is supplied. Off : indicates that the DC5V power is not supplied or reset switch is on. <table border="1"> <thead> <tr> <th>State</th> <th>Details</th> </tr> </thead> <tbody> <tr> <td>Off</td> <td>Hardware error Power supply error</td> </tr> <tr> <td>n times flash</td> <td>I/O modules failure (n is modules failure point)</td> </tr> <tr> <td>On</td> <td>No error</td> </tr> </tbody> </table>	State	Details	Off	Hardware error Power supply error	n times flash	I/O modules failure (n is modules failure point)	On	No error					
	State	Details														
	Off	Hardware error Power supply error														
n times flash	I/O modules failure (n is modules failure point)															
On	No error															
HOLD	Output hold (Green)	Display the output hold function status. <table border="1"> <thead> <tr> <th>State</th> <th>Details</th> </tr> </thead> <tbody> <tr> <td>Off</td> <td>Disable the output hold function</td> </tr> <tr> <td>On</td> <td>Enable the output hold function</td> </tr> </tbody> </table>	State	Details	Off	Disable the output hold function	On	Enable the output hold function								
State	Details															
Off	Disable the output hold function															
On	Enable the output hold function															
BF	Error (Red)	Display PROFIBUS error status or EH-IOCP2 hardware status. <table border="1"> <thead> <tr> <th>State</th> <th>Details</th> </tr> </thead> <tbody> <tr> <td>Off</td> <td>No error</td> </tr> <tr> <td>Blinking</td> <td>Communication timeout</td> </tr> <tr> <td>Single-flash</td> <td>Communication data failure I/O modules failure</td> </tr> <tr> <td>Double-flash</td> <td>Mount not support modules Mount at out of area</td> </tr> <tr> <td>Triple-flash</td> <td>I/O data size over</td> </tr> <tr> <td>On</td> <td>Internal error</td> </tr> </tbody> </table>	State	Details	Off	No error	Blinking	Communication timeout	Single-flash	Communication data failure I/O modules failure	Double-flash	Mount not support modules Mount at out of area	Triple-flash	I/O data size over	On	Internal error
State	Details															
Off	No error															
Blinking	Communication timeout															
Single-flash	Communication data failure I/O modules failure															
Double-flash	Mount not support modules Mount at out of area															
Triple-flash	I/O data size over															
On	Internal error															

The state of LED is indicated below.

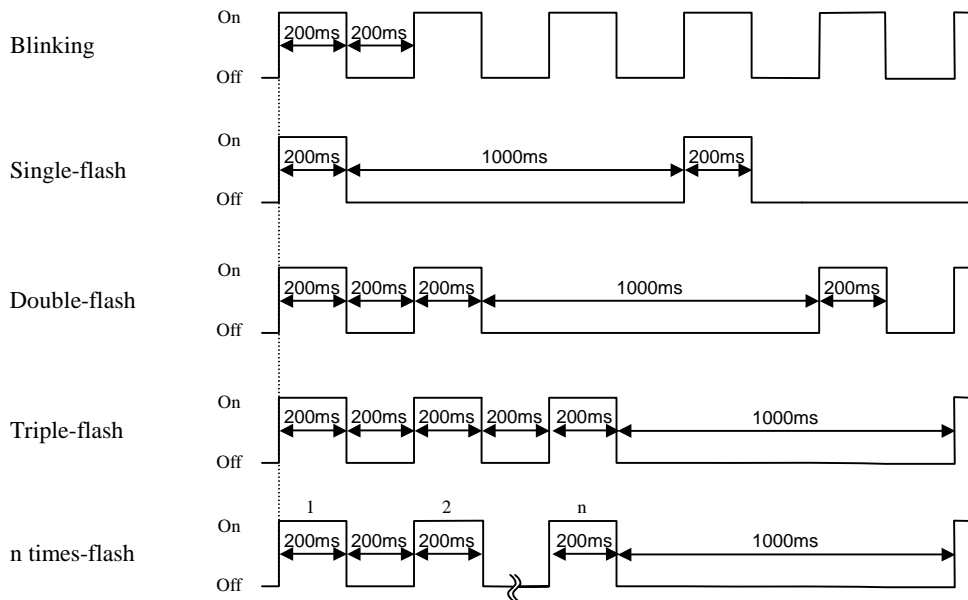

Rotary switch

Rotary switch	Symbol	Meaning	Details of setting
<p>[Default setting: 00]</p>	×10 (tens place)	Station No. (00 to 99)	The station No. of PROFIBUS network is set from 00 to 99. The tens place set by upper rotary switch. The ones place set by lower rotary switch.
	×1 (ones place)		

■ Description of Bottom DIP switch

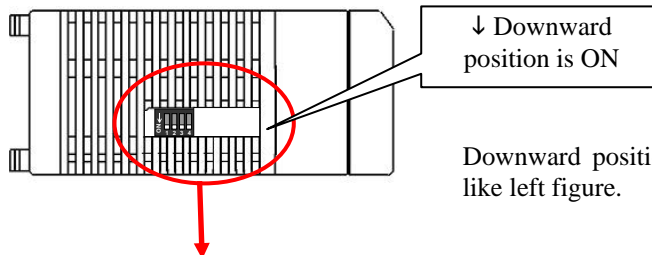

Downward position is ON side in case of bottom view like left figure.

No.	Setting description	Details									
1	Output hold function selecting [Default setting: OFF]	When the communication timeout error occurred, it is selected whether the output data from the master is held or not. (Hold means the last data received properly is fixed.) <table border="1"> <thead> <tr> <th>Bit1</th> <th>Position</th> <th>Output hold function selection</th> </tr> </thead> <tbody> <tr> <td>OFF</td> <td></td> <td>Disable the output hold function (Turn off all output data from the master at the communication error.)</td> </tr> <tr> <td>ON</td> <td></td> <td>Enable the output hold function (At the communication error, output data from master is held with last data received properly.)</td> </tr> </tbody> </table>	Bit1	Position	Output hold function selection	OFF		Disable the output hold function (Turn off all output data from the master at the communication error.)	ON		Enable the output hold function (At the communication error, output data from master is held with last data received properly.)
Bit1	Position	Output hold function selection									
OFF		Disable the output hold function (Turn off all output data from the master at the communication error.)									
ON		Enable the output hold function (At the communication error, output data from master is held with last data received properly.)									
2	EH-IOCP compatible mode selecting [Default setting: OFF]	It can select whether the EH-IOCP2 operates as standard mode or compatible mode. <table border="1"> <thead> <tr> <th>Bit2</th> <th>Position</th> <th>EH-IOCP compatible mode selection</th> </tr> </thead> <tbody> <tr> <td>OFF</td> <td></td> <td>Standard mode (EH-IOCP2)</td> </tr> <tr> <td>ON</td> <td></td> <td>Compatible mode (EH-IOCP)</td> </tr> </tbody> </table>	Bit2	Position	EH-IOCP compatible mode selection	OFF		Standard mode (EH-IOCP2)	ON		Compatible mode (EH-IOCP)
Bit2	Position	EH-IOCP compatible mode selection									
OFF		Standard mode (EH-IOCP2)									
ON		Compatible mode (EH-IOCP)									
3	Data swap function selecting [Default setting: OFF]	It can select whether it performs byte swap by a word unit. <table border="1"> <thead> <tr> <th>Bit3</th> <th>Position</th> <th>Data swap function selection</th> </tr> </thead> <tbody> <tr> <td>OFF</td> <td></td> <td>Disable the data swap function</td> </tr> <tr> <td>ON</td> <td></td> <td>Enable the data swap function</td> </tr> </tbody> </table>	Bit3	Position	Data swap function selection	OFF		Disable the data swap function	ON		Enable the data swap function
Bit3	Position	Data swap function selection									
OFF		Disable the data swap function									
ON		Enable the data swap function									
4	No use [Default setting: OFF]	Please keep off.									

Table 2.2-1 Functional specifications

Item		Specifications		
		EH-IOCP2		EH-IOCP
		Standard mode	EH-IOCP compatible mode	
Communication specifications	Communication protocol	PROFIBUS-DP V0		
	Range of node address	0 to 99: Setting by rotary switch		
	Maximum I/O size	Input: 244 bytes, output: 244 bytes*2		
	Connector	D-sub 9 pin		
	Topology	BUS		
	Communication cable	PROFIBUS cable		
	Segment length,	9.6	kbps	: 1,200 m
	Transmit speed	19.2	kbps	: 1,200 m
		93.75	kbps	: 1,200 m
		187.5	kbps	: 1,000 m
		500	kbps	: 400 m
		1500	kbps	: 200 m
		3	Mbps	: 100 m
		6	Mbps	: 100 m
	12	Mbps	: 100 m	
Output hold	Supported*3			
Data swap	Supported		Not supported	
Termination	Not built-in		Built-in	
GSD file	HITA0E64.GSD	HITA049D.GSD		
Functional specifications	Support base unit	EH-BS3 / 5 / 8 / 3A / 5A / 6A / 8A / 11A / 8R		EH-BS3 / 5 / 8 / 3A / 5A / 6A / 8A
	Number of modules	22 modules / EH-IOCP2		16 modules / EH-IOCP(2)
	Number of I/O points	1,408 points: Digital I/O 176 ch : Analog I/O*2		1,024 points: Digital I/O, 128 ch : Analog I/O
	Expansion unit	1 (use EH-IOC, EH-IOCH or EH-IOCH2)		
	Refresh time	500 μs		5 ms
	Self-check	WDT check		WDT check System memory check
	Error indication	LED		
	Current consumption	350 mA		600 mA
	Standard compliant	CE, C-Tick*1		UL, CE, C-Tick

*1 UL is not supported. Contact your local supplier for further information.

*2 Each I/O size of EH-IOCP2 is expanded from 128 bytes to 244 bytes by software version 0014 or newer.

*3 The output hold function of EH-IOCP2 is supported by software version 0014 or newer.









CAUTION

EH-IOCP2 supports digital I/O modules, Analog I/O modules (incl. RTD and Thermocouple), counter modules and positioning modules only. Note that the others are not supported. Do not use unsupported modules with EH-IOCP2.

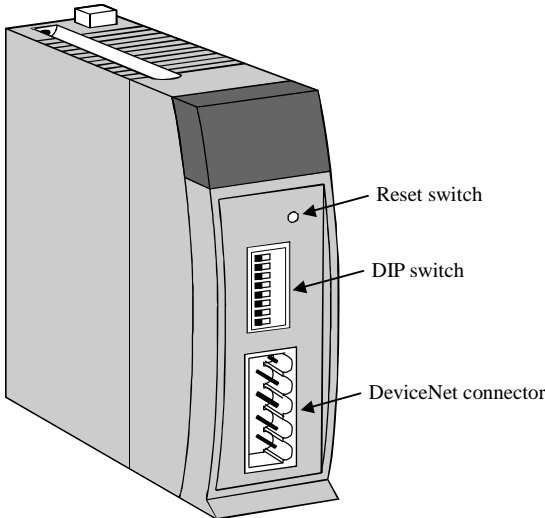
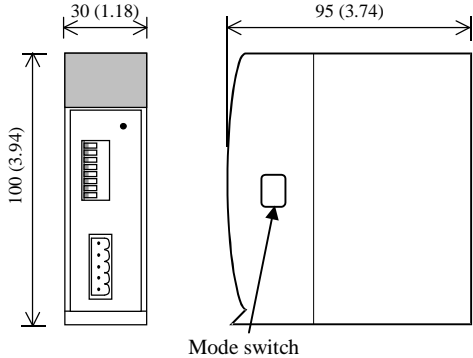
For information on the GSD files for EH-IOCP2, contact your local supplier.

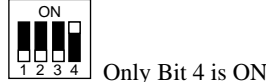
2.9.5 DeviceNet module

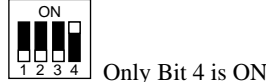
(1) DeviceNet master module : EH-RMD

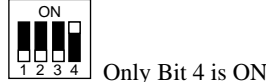
Module features		Type (Weight)	EH-RMD (Approx. 0.13 kg (0.29lb.))				
		Dimensions (mm (in.))					
		<p>Reset switch</p> <p>DIP switch</p> <p>DeviceNet connector</p> <p>Mode switch</p>					
Name	Description						
Reset switch	The module is reset if this switch is pressed.						
DIP switch	Sets up the node address and the communication speed.						
DeviceNet connector	This is a connector for connecting to the network. Use an attached connector.						
Mode switch	<p>EH-RMD of SOFTWARE VER.02 has supported Link mode and remote mode however, EHV+ series CPU supports Link mode only.</p> <table border="1" data-bbox="582 1021 1286 1164"> <tr> <td>Link mode</td> <td>Remote mode</td> </tr> <tr> <td>  <p>All OFF</p> </td> <td>  <p>Only Bit 4 is ON</p> </td> </tr> </table> <p>Put the attached protect sheet on the mode switch.</p> <p>EH-RMD (before "SOFTWARE VER.02") supports link mode only. This switch is covered by a protect sheet. Do not set this switch.</p>			Link mode	Remote mode	 <p>All OFF</p>	 <p>Only Bit 4 is ON</p>
Link mode	Remote mode						
 <p>All OFF</p>	 <p>Only Bit 4 is ON</p>						

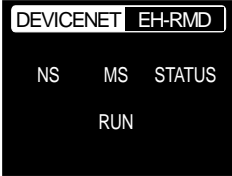

LED display

Front view	LED	Details	Color
	NS	Indicates the status of the network by combination of illumination color and flashing count	Green / Red
	MS	Indicates the status of the communication interface board by combination of the illumination color and flashing count.	Green / Red
	RUN	Indicates the status of the module and the CPU module by the flashing pattern.	Green / Red
	STATUS	Indicates the status of the PLC interface board by combination of illumination color and flashing count.	Green / Red

Setup node address and communication speed

External view	Node address	NA1	NA2	NA4	NA8	NA16	NA32	Communication speed	DR0	DR1
	0	OFF	OFF	OFF	OFF	OFF	OFF	125	OFF	OFF
	1	ON	OFF	OFF	OFF	OFF	OFF	250	ON	OFF
	2	OFF	ON	OFF	OFF	OFF	OFF	500	OFF	ON
	:	:	:	:	:	:	:		ON	ON
	:	:	:	:	:	:	:			
	62	OFF	ON	ON	ON	ON	ON			
63	ON	ON	ON	ON	ON	ON				

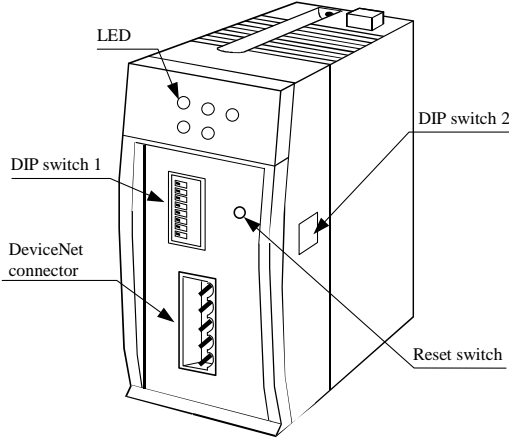
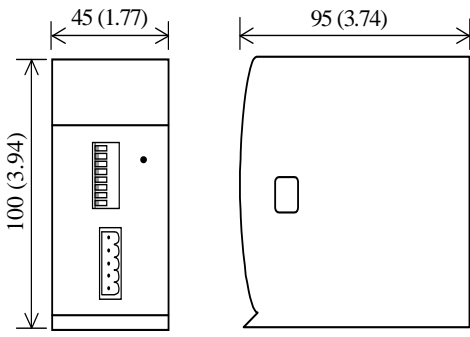
(2) DeviceNet slave Controller : EH-IOCD/2

Module features		Type (Weight)	EH-IOCD (Approx. 0.17kg (0.37lb.))	
		Dimensions (mm (in.))		
Name	Description			
LED	This is a LED for indicating the network status and error information.			
DIP switch 1	Sets up the node address and the communication speed.			
DeviceNet connector	This is a connector for connecting to the network. Use an attached connector.			
Reset switch	The module is reset if this switch is pressed.			
DIP switch 2	This is a switch for specifying that the status of the output module on EH-IOCD is 'OFF' or 'HOLD' at the communication error or at the stop of the CPU module.			
	 All is OFF		 Only Bit 4 is ON	

LED display

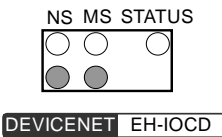
Front view	LED	Details	Color
	NS	Indicates the network status by combination of illumination color and flashing count.	Green / Red
	MS	Indicates the status of the communication interface board by combination color and flashing count.	Green / Red
	STATUS	Indicates the status of PLC interface board by combination of illumination color and flashing count.	Green / Red

*  Gray colored LEDs are not used.

Setup node address and communication speed

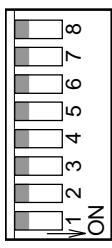
External view	Node address	NA1	NA2	NA4	NA8	NA16	NA32	Communication speed	DR0	DR1
	0	OFF	OFF	OFF	OFF	OFF	OFF	125	OFF	OFF
	1	ON	OFF	OFF	OFF	OFF	OFF	250	ON	OFF
	2	OFF	ON	OFF	OFF	OFF	OFF	500	OFF	ON
	:	:	:	:	:	:	:		ON	ON
	:	:	:	:	:	:	:			
	62	OFF	ON	ON	ON	ON	ON			
	63	ON	ON	ON	ON	ON	ON			

DeviceNet master / slave module

Common Specifications

Item	Specification																
Communication protocol	DeviceNet 2.0 standard																
Supported connections	<ol style="list-style-type: none"> 1. Poll I/O connection 2. Bit Strobe I/O connection 3. Cyclic I/O connection 4. Change of State (COS) I/O connection 5. Explicit Message connection 																
Connection mode	<ol style="list-style-type: none"> 1. Multi-drop connection 2. Multi-drop connecting using T-branch 																
Communication speed	500k / 250k / 125 kbps (switched by DIP switch)																
Cable	Dedicated DeviceNet cable *																
Communication distance	<p>The below data is based on thick trunk cable used.</p> <table border="1"> <thead> <tr> <th>Communication speed</th> <th>Maximum network length</th> <th>Each sub-line length</th> <th>Total sub-line length</th> </tr> </thead> <tbody> <tr> <td>500k bits/s</td> <td>100m or less</td> <td>6m or less</td> <td>39m or less</td> </tr> <tr> <td>250k bits/s</td> <td>250m or less</td> <td>6m or less</td> <td>78m or less</td> </tr> <tr> <td>125k bits/s</td> <td>500m or less</td> <td>6m or less</td> <td>156m or less</td> </tr> </tbody> </table>	Communication speed	Maximum network length	Each sub-line length	Total sub-line length	500k bits/s	100m or less	6m or less	39m or less	250k bits/s	250m or less	6m or less	78m or less	125k bits/s	500m or less	6m or less	156m or less
Communication speed	Maximum network length	Each sub-line length	Total sub-line length														
500k bits/s	100m or less	6m or less	39m or less														
250k bits/s	250m or less	6m or less	78m or less														
125k bits/s	500m or less	6m or less	156m or less														

* We recommend the followings as communication cables and crimp type terminals for cables.

Made by Showa Densen TDN18-**G Trunk cable (thick cable)

TDN24-**G Drop cable (thin cable)

(** indicates the number of 'm's. Available lengths are 10 / 30 / 50 / 100 / 300 / 500m.)

Made by Nichifu TME TC-2-11 Crimp type terminal for trunk cable (power supply line)

TME TC-1.25-11 Crimp type terminal for trunk cable (communication line)

TME TC-0.5 Crimp type terminal for drop cable (common to power supply line / communication line)

NH-32 Crimp tool

DeviceNet connector

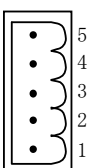
External view of connector	No.	Signal	Wiring color
	5	V+	Red
	4	CAN_H	White
	3	Drain	No colored
	2	CAN_L	Blue
	1	V-	Black

Specifications

Item	Specifications	
	EH-RMD	EH-IOCD
Mounting position	Slot 0 to 7 of basic base (max. 8 modules)	- (CPU's position)
Supported I/O module	-	16 units (use EH-IOCH2 to install more than 11 modules.)
Output data	256 words	256 words
Input data	256 words	256 words
Number of slave units	63 units	63 units
Internal current consumption	280mA maximum	320mA maximum

<p>Module features</p>		<p>Type (weight)</p> <p>EH-IOCD2 (0.14kg (0.31lb))</p>	
<p>Dimensions (mm (in.))</p>			
No.	Name	Function	Remarks
1]	Lock button	Press this button to dismount. Module can be fixed firmly by a screw of M4 × 10mm (0.39in).	
2]	Communication connector	Open plug connector for communication cable.	
3]	LED display	The status of module is displayed on this LED.	
4]	Node address switch	This is a switch to set the node address. Node address range is 00 to 63.	
5]	Reset switch	The module can be reset by pressing this switch when the module detected an error.	
6]	Bottom DIP switch	This is a switch to set an operation mode (the output hold, etc.).	

Connector

Connector	Symbol	Indication	Details																		
<p>DeviceNet</p>	DeviceNet	Communication connector	<p>Open plug connector.</p> <p>Terminal layouts are shown below.</p> <table border="1"> <thead> <tr> <th>Pin No.</th> <th>Signal</th> <th>Wire color</th> </tr> </thead> <tbody> <tr> <td>5</td> <td>V+</td> <td>Red</td> </tr> <tr> <td>4</td> <td>CAN_H</td> <td>White</td> </tr> <tr> <td>3</td> <td>Drain</td> <td>Bare wire</td> </tr> <tr> <td>2</td> <td>CAN_L</td> <td>Blue</td> </tr> <tr> <td>1</td> <td>GND</td> <td>Black</td> </tr> </tbody> </table>	Pin No.	Signal	Wire color	5	V+	Red	4	CAN_H	White	3	Drain	Bare wire	2	CAN_L	Blue	1	GND	Black
Pin No.	Signal	Wire color																			
5	V+	Red																			
4	CAN_H	White																			
3	Drain	Bare wire																			
2	CAN_L	Blue																			
1	GND	Black																			

Rotary switch

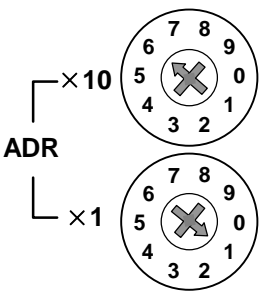
Rotary switch	Symbol	Meaning	Details of setting
 <p>[Default setting: 00]</p>	$\times 10$ (tens place)	Station No. (00 to 63)	The station No. of DeviceNet network is set from 00 to 63. The tens place set by upper rotary switch. The ones place set by lower rotary switch. Node address range is 00 to 63. If you set higher than 63, EH-IOCD2 operates as node address 63.
	$\times 1$ (ones place)		

LED display

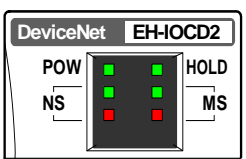
LED	LED name	Indication	Details								
	POW	Power supply (Green)	On : indicates that the DC5V power is supplied. Off : indicates that the DC5V power is not supplied or reset switch is on. <table border="1" data-bbox="734 817 1364 1041"> <thead> <tr> <th>State</th> <th>Details</th> </tr> </thead> <tbody> <tr> <td>Off</td> <td>Hardware error Power supply error</td> </tr> <tr> <td>n times flash</td> <td>I/O modules failure (n is modules failure point)</td> </tr> <tr> <td>On</td> <td>No error</td> </tr> </tbody> </table>	State	Details	Off	Hardware error Power supply error	n times flash	I/O modules failure (n is modules failure point)	On	No error
	State	Details									
	Off	Hardware error Power supply error									
	n times flash	I/O modules failure (n is modules failure point)									
On	No error										
HOLD	Output hold (Green)	Display the output hold function status. <table border="1" data-bbox="734 1086 1364 1198"> <thead> <tr> <th>State</th> <th>Details</th> </tr> </thead> <tbody> <tr> <td>Off</td> <td>Disable the output hold function</td> </tr> <tr> <td>On</td> <td>Enable the output hold function</td> </tr> </tbody> </table>	State	Details	Off	Disable the output hold function	On	Enable the output hold function			
State	Details										
Off	Disable the output hold function										
On	Enable the output hold function										
NS	DeviceNet status (Green / Red)	Indicates DeviceNet network status.									
MS	EH-IOCD2 status (Green / Red)	Indicates EH-IOCD2 status.									

The detail of NS and MS LED are indicated below.

Indicate pattern	Description	Actions
MS Lit in green NS Lit in green	I/O connection established.	—
MS Turned off NS Turned off	Hardware failure. The power is not properly supplied to the EH-IOCD2.	<ul style="list-style-type: none"> • Check power of power supply module. • Replace EH-IOCD2.
MS Lit in red NS Turned off	Internal error occurred.	Replace EH-IOCD2.
MS Lit in green NS Blinking in red	Communication timeout occurred.	<ul style="list-style-type: none"> • Check the connection of the communication cable. • Check there are no sources of noise near the communication cable.
MS Lit in green NS Lit in red	Node address overlaps. It is detected that the bus is not functioning.	<ul style="list-style-type: none"> • Check node address and communication speed of each device. • Check the connection of the communication cable. • Check the terminal resistor is connected properly. • Check that the cable length is within the specification range.
MS Lit in green NS Turned off	a. No power supply to the network. b. Node address is being checked whether address is overlap or not.	a. Check the 24 V DC is supplied. b. Check node address and communication speed of each device.
MS Lit in green NS Blinking in green	a. I/O connection not established. b. Node address is unmatched	a. Check the master unit is set configuration. b. Check node address and communication speed of each device.
MS Blinking in green NS -	Node address switch was changed after the initial operation.	<ul style="list-style-type: none"> • Set the node address switch to former address. • Reset EH-IOCD2.
MS Single-flash in green NS -	I/O modules error occurred.	Replace I/O modules. (The number of blinking in POW LED indicates the position of failure module.)
MS Double-flash in green NS -	a. Nonsupport modules are mounted. b. The I/O modules were mounted outside range slot.	Check system and node address and push reset switch of EH-IOCD2.
MS Triple-flash in green NS -	Total input and output size are zero or exceed maximum.	Check the installation. The total sum of input and output sizes must be greater than zero and less than 177 words.



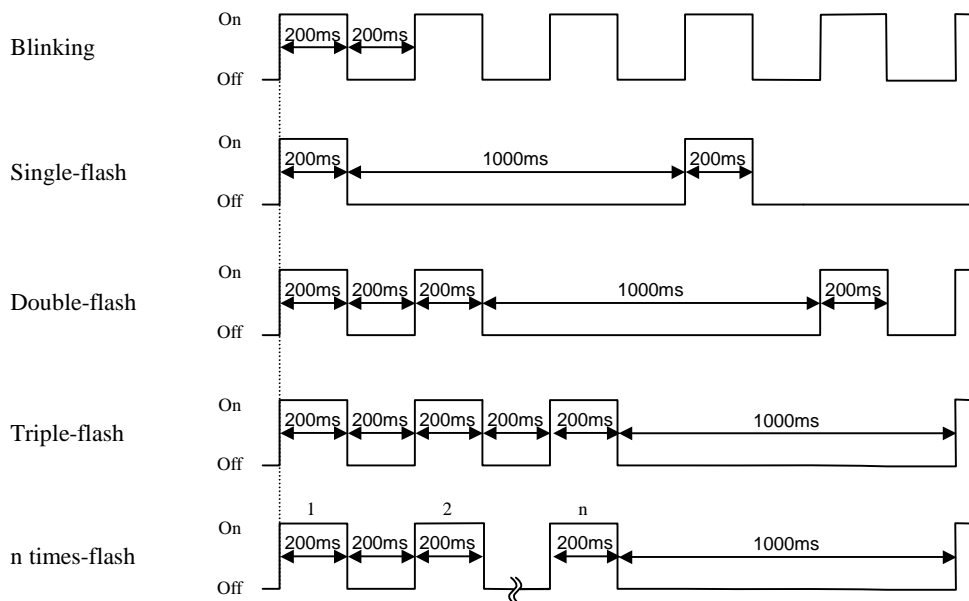



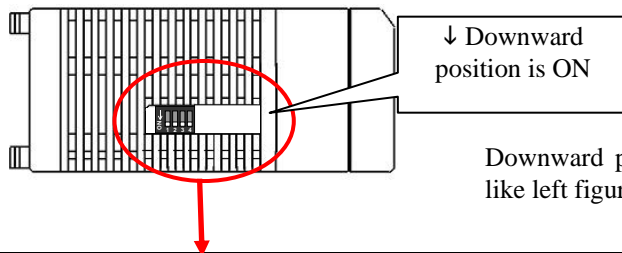









The state of LED is indicated below.



Bottom DIP switch



Downward position is ON side in case of bottom view like left figure.

No.	Setting description	Details									
1	Output hold function selecting  [Default setting: OFF]	When the communication timeout error occurred, it is selected whether the output data from the master is held or not. (Hold means the last data received properly is fixed.) Output hold function may be changed action depending on master unit. Please read master's manual and check the combination master unit and EH-IOCD2, before using output hold function of EH-IOCD2. <table border="1" style="width: 100%; border-collapse: collapse;"> <thead> <tr> <th>Bit1</th> <th>Position</th> <th>Output hold function selection</th> </tr> </thead> <tbody> <tr> <td>OFF</td> <td></td> <td>Disable the output hold function (Turn off all output data from the master at the communication error.)</td> </tr> <tr> <td>ON</td> <td></td> <td>Enable the output hold function (At the communication error, output data from master is held with last data received properly.)</td> </tr> </tbody> </table>	Bit1	Position	Output hold function selection	OFF		Disable the output hold function (Turn off all output data from the master at the communication error.)	ON		Enable the output hold function (At the communication error, output data from master is held with last data received properly.)
Bit1	Position	Output hold function selection									
OFF		Disable the output hold function (Turn off all output data from the master at the communication error.)									
ON		Enable the output hold function (At the communication error, output data from master is held with last data received properly.)									
2	EH-IOCD compatible mode selecting  [Default setting: OFF]	It can select whether the EH-IOCD2 operates as standard mode or compatible mode. <table border="1" style="width: 100%; border-collapse: collapse;"> <thead> <tr> <th>Bit2</th> <th>Position</th> <th>EH-IOCD compatible mode selection</th> </tr> </thead> <tbody> <tr> <td>OFF</td> <td></td> <td>Standard mode (EH-IOCD2)</td> </tr> <tr> <td>ON</td> <td></td> <td>Compatible mode (EH-IOCD)</td> </tr> </tbody> </table>	Bit2	Position	EH-IOCD compatible mode selection	OFF		Standard mode (EH-IOCD2)	ON		Compatible mode (EH-IOCD)
Bit2	Position	EH-IOCD compatible mode selection									
OFF		Standard mode (EH-IOCD2)									
ON		Compatible mode (EH-IOCD)									
3	No use  [Default setting: OFF]	Please keep off.									
4	No use  [Default setting: OFF]	Please keep off.									

Replacing from EH-IOCD2

There are some differences between EH-IOCD2 and EH-IOCD.

- (1) Method of node address setting.
 EH-IOCD: DIP switch.
 EH-IOCD2: Rotary switch.
- (2) Method of communication baud rate.
 EH-IOCD: DIP switch.
 EH-IOCD2: It is not necessary by using auto baud rate function.

EH-IOCD2 supports compatible mode to replace EH-IOCD without re-configuration of DeviceNet master.



CAUTION

When EH-IOCD2 is in compatible mode, EDS file and the number of I/O modules are different from standard mode.

Performance specification

Item		Specifications				
		EH-IOCD2		EH-IOCD		
		Standard mode	EH-IOCD compatible mode			
Communication specifications	Communication protocol	Conform to DeviceNet Release 2.0				
	Supported connection	(1) Polling I/O connection (2) Bit Strobe I/O connection (3) Cyclic I/O connection (4) Change of State I/O connection (5) Explicit Message I/O connection				
	Range of node address	0 to 63 : Setting by rotary switch				
	Maximum I/O size	Input : 256 words, output : 256 words				
	Connector	DeviceNet open plug connector				
	Topology	Multi drop connection, Multi branch connection using by Device tap				
	Communication cable	DeviceNet cable				
	Maximum Segment length, Transmit speed	Baud rates	Network length		Each drop line length	Total drop line length
			Thick cable	Thin cable		
		500kbps	100m	100m	6m	39m
		250kbps	250m	100m	6m	78m
		125kbps	500m	100m	6m	156m
	Communication baud rate setting	Auto baud rate function		DIP switch		
Output hold	Supported					
Termination	Not built-in					
EDS file	EH-IOCD2.EDS	EH-IOC~1.EDS				
Functional specifications	Support base unit	EH-BS3/5/8/3A/5A/6A/8A/11A/8R	EH-BS3/5/8/3A/5A/6A/8A			
	Number of modules	22 modules / EH-IOCD2	16 modules / EH-IOCD(2)			
	Number of I/O points	1,408 points: Digital I/O 176 ch : Analog I/O	1,024 points: Digital I/O 128 ch : Analog I/O			
	Expansion unit	1 (use EH-IOC, EH-IOCH or EH-IOCH2)				
	Refresh time	500 μs		5 ms		
	Self-check	WDT check		WDT check System memory check		
	Error indication	LED				
	Current consumption	250 mA		600 mA		
Standard compliant	CE, C-Tick*1		UL, CE, C-Tick			

*1 UL is not supported. Contact your local supplier for further information.

 CAUTION
EH-IOCD2 supports digital I/O modules, Analog I/O modules (incl. RTD and Thermocouple), counter modules and positioning modules only. Note that the others are not supported. Do not use unsupported modules with EH-IOCD2.

For information on the EDS files for EH-IOCD2, contact your local supplier.

2.9.6 EtherCAT module

EtherCAT slave Controller : EH-IOCA

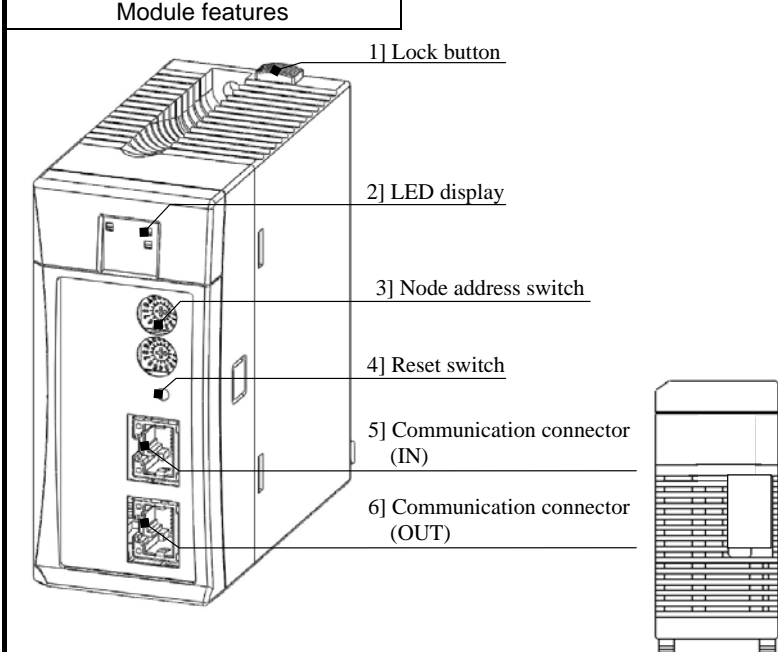
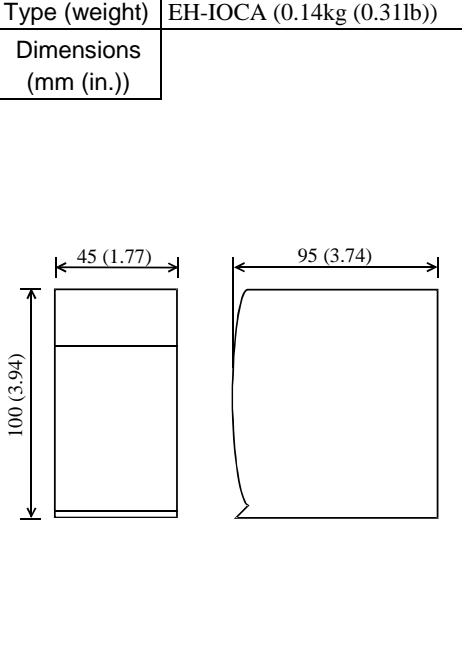
Module features		Type (weight)	EH-IOCA (0.14kg (0.31lb))
		Dimensions (mm (in.))	
			
No.	Name	Function	Remarks
1]	Lock button	Press this button to dismount. Module can be fixed firmly by a screw of M4 × 10mm (0.39in).	
2]	LED display	The status of module is displayed on this LED.	
3]	Node address switch	This is a switch to set the node address.	
4]	Reset switch	The module can be reset by pressing this switch when error such as the module abnormal occurred.	
5]	Communication connector (IN)	This is a connector to connect a cable for communication.	
6]	Communication connector (OUT)	This is a connector to connect a cable for communication.	

LED display

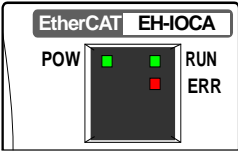
LED	LED name	Indication	Details													
	POW	Power supply (Green)	On : indicates that the DC5V power is supplied. Off : indicates that the DC5V power is not supplied or reset switch is on.													
	RUN	Status (Green)	Display an EtherCAT® communication status. <table border="1" data-bbox="738 371 1369 573"> <thead> <tr> <th>State</th> <th>Details</th> </tr> </thead> <tbody> <tr> <td>Off</td> <td>Init</td> </tr> <tr> <td>Blinking</td> <td>PRE-OPERATIONAL</td> </tr> <tr> <td>Single-flash</td> <td>SAFE-OPERATIONAL</td> </tr> <tr> <td>On</td> <td>OPERATIONAL</td> </tr> </tbody> </table>	State	Details	Off	Init	Blinking	PRE-OPERATIONAL	Single-flash	SAFE-OPERATIONAL	On	OPERATIONAL			
	State	Details														
Off	Init															
Blinking	PRE-OPERATIONAL															
Single-flash	SAFE-OPERATIONAL															
On	OPERATIONAL															
ERR	Error (Red)	Display EtherCAT® error status or EH-IOCA hardware status. <table border="1" data-bbox="738 613 1393 927"> <thead> <tr> <th>State</th> <th>Details</th> </tr> </thead> <tbody> <tr> <td>Off</td> <td>No error</td> </tr> <tr> <td>Blinking</td> <td>Configuration error</td> </tr> <tr> <td>Single-flash</td> <td>EtherCAT® synchronism failure Communication data failure</td> </tr> <tr> <td>Double-flash</td> <td>Application watchdog timeout</td> </tr> <tr> <td>Flickering</td> <td>Boot error</td> </tr> <tr> <td>On</td> <td>PDI watchdog timeout</td> </tr> </tbody> </table>	State	Details	Off	No error	Blinking	Configuration error	Single-flash	EtherCAT® synchronism failure Communication data failure	Double-flash	Application watchdog timeout	Flickering	Boot error	On	PDI watchdog timeout
State	Details															
Off	No error															
Blinking	Configuration error															
Single-flash	EtherCAT® synchronism failure Communication data failure															
Double-flash	Application watchdog timeout															
Flickering	Boot error															
On	PDI watchdog timeout															

The state of LED is indicated below.

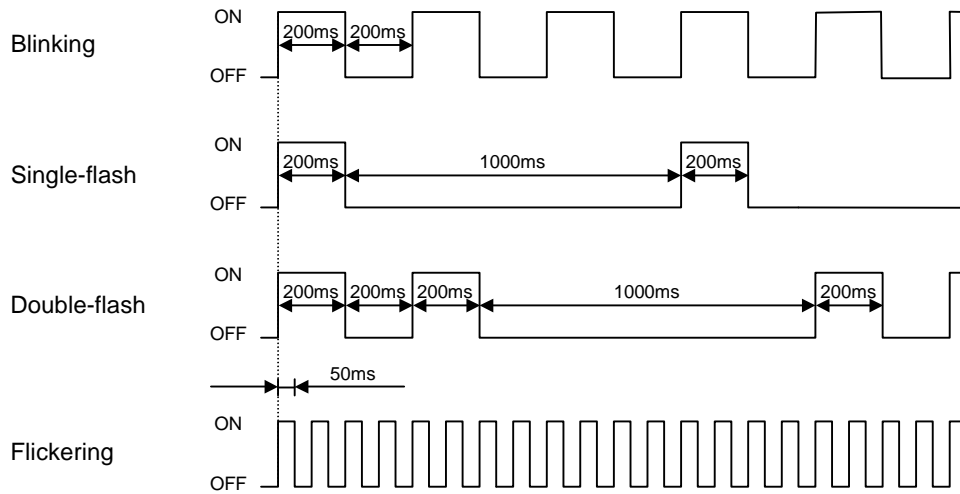

Rotary switch

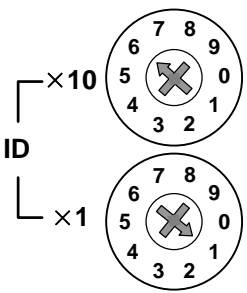
Rotary switch	Symbol	Meaning	Details of setting
 <p>[Default setting: U=0, L=0]</p>	$\times 10$ (tens place)	Station No. (1 to 99)	The station No. of EtherCAT [®] network is set from 1 to 99. The tens place set by upper rotary switch. The ones place set by lower rotary switch.
	$\times 1$ (ones place)		

Node address of EH-IOCA is set by node address method of EtherCAT[®] master unit. If EtherCAT[®] master use fixed node address method, rotary switch of EH-IOCA is valid. If EtherCAT[®] master use logic node address method or auto increment address method, rotary switch of EH-IOCA is invalid. If EtherCAT[®] master use logic nodes address method or auto increment address method, please set the rotary switch to “00”.

Connectors

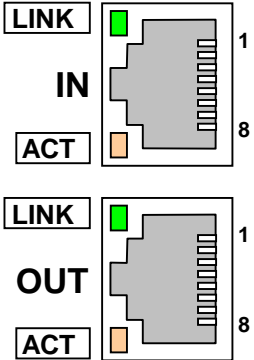
Connector	Symbol	Indication	Details																		
	IN	Communication connector	RJ45 8-pin connector. Terminal layouts are shown below. <table border="1" data-bbox="845 952 1268 1310"> <thead> <tr> <th>Pin No.</th> <th>Details</th> </tr> </thead> <tbody> <tr> <td>1</td> <td>Send data + (TD+)</td> </tr> <tr> <td>2</td> <td>Send data - (TD-)</td> </tr> <tr> <td>3</td> <td>Receive data + (RD+)</td> </tr> <tr> <td>4</td> <td>NC</td> </tr> <tr> <td>5</td> <td>NC</td> </tr> <tr> <td>6</td> <td>Receive data - (RD-)</td> </tr> <tr> <td>7</td> <td>NC</td> </tr> <tr> <td>8</td> <td>NC</td> </tr> </tbody> </table>	Pin No.	Details	1	Send data + (TD+)	2	Send data - (TD-)	3	Receive data + (RD+)	4	NC	5	NC	6	Receive data - (RD-)	7	NC	8	NC
	Pin No.	Details																			
	1	Send data + (TD+)																			
	2	Send data - (TD-)																			
3	Receive data + (RD+)																				
4	NC																				
5	NC																				
6	Receive data - (RD-)																				
7	NC																				
8	NC																				
OUT																					
LINK	LINK LED (Green)	LINK LED light up if the communication device are connected with a cable.																			
ACT	ACT LED (Orange)	ACT LED is flashing during operation.																			

Specifications

Item		Specifications
Communication specifications	Communication protocol	EtherCAT [®] protocol
	Transmit modulation method	Base band
	Transmit speed	100Mbps
	Physical layer	100BASE-TX (IEEE802.3)
	Connector	RJ45 (IN, OUT)
	Topology	Daisy-chain
	Recommended cable	CAT5 or higher, STP cable
	Maximum segment length	100 m
	Communication cycle	200μs or over *1
	Node address range	1 to 99:Setting by rotary switch 1 to 65,535:Setting by EtherCAT [®] master
	Process data	Fixed PDO mapping
	Mailbox	Support
	Cycle mode	Free Run mode (asynchronous)
	Output hold	Support
Functional specifications	Support base unit	EH-BS3A/5A/6A/8A/11A/8R
	Number of modules	22 modules / EH-IOCA
	Number of I/O points	1,408 points: Digital I/O 176 ch : Analog I/O
	Expansion unit	1
	Refresh time	500μs
	Self-check	WDT check
	Error indication	LED
	Current consumption	350mA

*1 The communication cycle is dependent on the specification of the EtherCAT[®] Master.

**CAUTION**

Digital I/O module, Analog I/O module, Resistance temperature detective input module, Thermocouple input module, counter module and positioning module are supported on the base unit using EH-IOCA. Note that the others are not supported.

Do not mount these modules on the slave base unit.

For information on the ESI files for EH-IOCA, contact your local supplier.

2.9.7 CPU Link Module

(1) Coaxial cable type

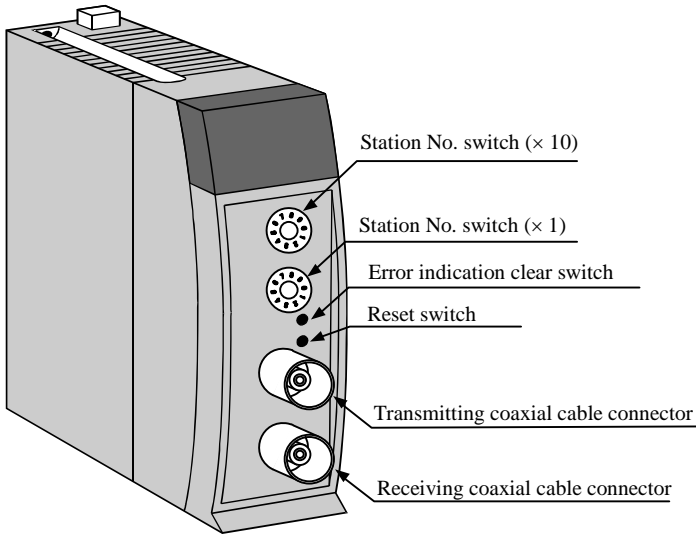
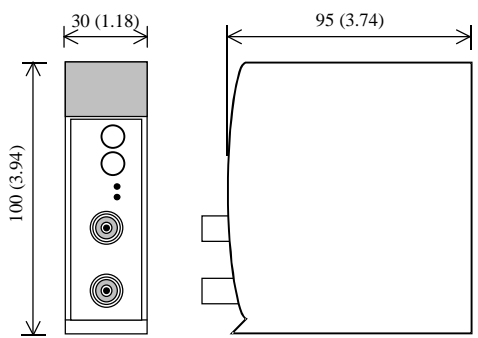
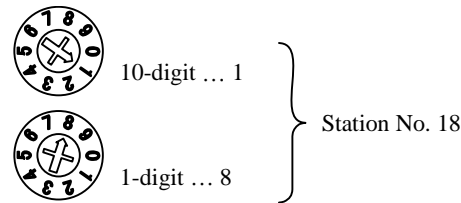
Module features		Type (Weight)	EH-LNK (Approx. 0.15kg (0.33lb))
		Dimension (mm (in.))	
Name	Description		
Station No. switch (× 10)	<p>This switch determines the link station No. The setting of this switch is validated when the power is turned on or the reset switch is pressed. The setting range is between 00 and 63. (Example) Sets the station No. to 18.</p>		
Station No. switch (× 1)	 <p>- Setting of 64 or higher triggers an out-of-range error for the station No. - Duplication of station No. triggers a duplication error for the station No. - If there is no station No.00 (master station) in the link system, it cannot work normally.</p>		
Error indication clear switch	Clears the indication displayed on ERR LED. (ERR LED will light up again if the error factor is not resolved.)		
Reset switch	The module is reset if this switch is pressed.		
Transmitting coaxial cable connector (TXD)	Transmits data from the own station. Connect to RXD on the next station using a coaxial cable.		
Receiving coaxial cable connector (RXD)	Receives data from other station. Connect to TXD on the next station using a coaxial cable.		

LED display

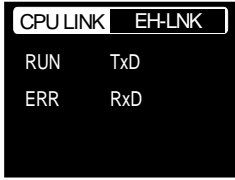
Front view of LED part	LED	Details	Color
	TxD	Flashes when data is received.	Green
	RxD	Flashes when data is transmitted.	Green
	RUN	Lights up when the link module is operating properly.	Green
	ERR	Normal state : OFF Error (data link is possible) : Flashing (in 1s interval) Error (data link is impossible) : Flashing (in 0.5s interval), turn on	Red

(2) Optical cable type

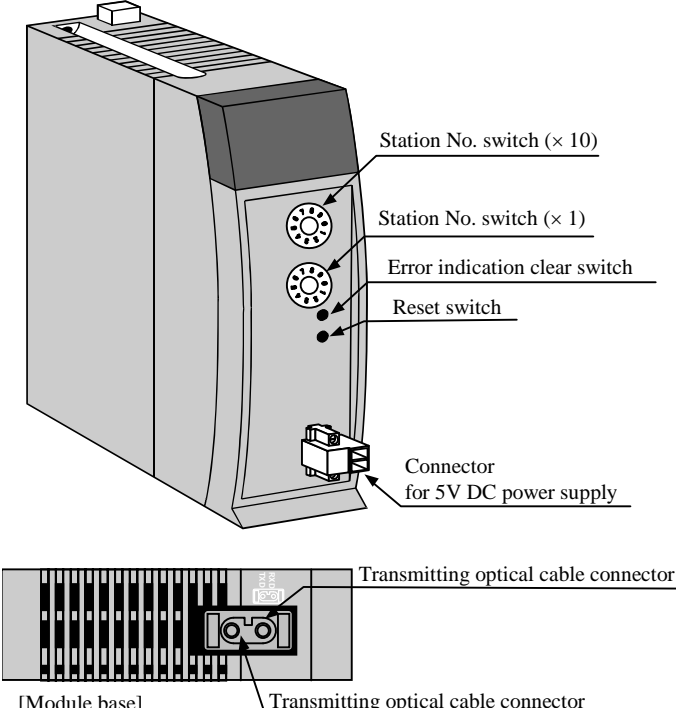
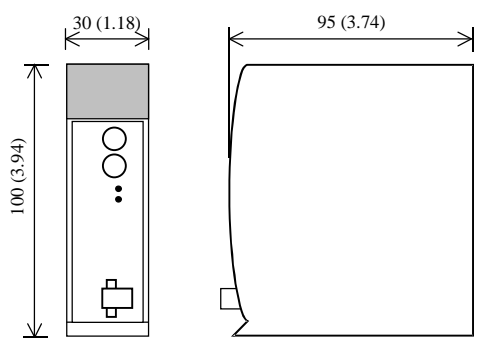
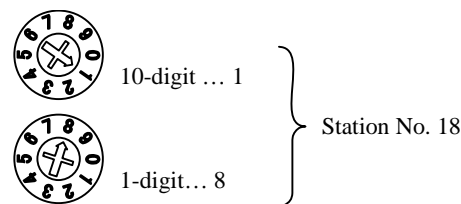
Module features		Type (Weight) EH-OLNK (Approx. 0.15kg (0.33lb.)) EH-OLNKG (Approx.0.15kg (0.33lb.)) EH-OLNKE (Approx. 0.15kg (0.33lb.))
 <p>Station No. switch (× 10)</p> <p>Station No. switch (× 1)</p> <p>Error indication clear switch</p> <p>Reset switch</p> <p>Connector for 5V DC power supply</p> <p>Transmitting optical cable connector</p> <p>[Module base]</p> <p>Transmitting optical cable connector</p>		Dimensions (mm (in.)) 
Name	Description	
Station No. switch (× 10)	This switch determines the link station No. The setting of this switch is validated when the power is turned on or the reset switch is pressed. The setting range is between 00 and 63. (Example) Sets the station No. to 18.	
Station No. switch (× 1)	 <p>10-digit ... 1</p> <p>1-digit... 8</p> <p>Station No. 18</p> <ul style="list-style-type: none"> - Setting of 64 or higher triggers an out-of-range error for the station No. - Duplication of the station No. trigger a duplication error for the station No. - If there is no station No.00 (master station) in the link system, it cannot operate normally. 	
Error indication clear switch	Clears the indication displayed on ERR LED. (ERR LED will light up again if the error factor is not resolved.)	
Reset switch	The module is reset if this switch is pressed.	
Connector for 5V DC power supply	Supply 5V DC from another power source if the link system needs to work while this module is not powered.	
Receiving optical cable connector (RXD)	Receives data from other station. Connect to the TXD on the next station by an optical cable.	
Transmitting optical cable connector (TXD)	Transmits data from other station. Connect to RXD on the next station by an optical cable.	

LED display

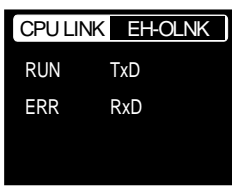
Front view	LED	Details	Color
	TxD	Flashes when data is received.	Green
	RxD	Flashes when data is transmitted.	Green
	RUN	Lights up when the link module is operating properly.	Green
	ERR	Normal state : OFF Error (data link is possible) : Flashing (in 1s interval) Error (data link is impossible) : Flashing (in 0.5s interval), turn on	Red

Specifications (CPU link module (coaxial, optical))

Item		Specification	
Functional Specification	Number of connected link modules	64 units at the maximum per link system	
	Number of link points	1,024 words per loop *1	
	Data delivery system	Common data area system	
	Transmit/Receive distinction on data area allocation	Parameter setup from peripheral devices	
	Station No. specifying	Specifies 0 to 63 by a rotary switch.	
	Transmission speed	1.0 Mbps	
	Transmission method	Half-duplex serial transmission, frame synchronization	
	Communication method	Token passing	
	Modulation method	Base band	
	Refresh time	At 64 stations connection and 1024 words transfer; Approx. 390ms	
	Error check	CRC, overrun check, timeout, open circuit parameter error (Dual specifying of station No., overlap of link area, etc.)	
	Self-diagnosis	System ROM/RAM check, watchdog timer check, transmission loop back check	
Transmission channel Specification	Transmission channel form	Loop type	
	Cable length	Between stations	500m max. (EH-LNK), 1,000m max. (EH-OLNK), 2,000m max. (EH-OLNKG,E)
		Total	1,000m max. (EH-LNK), 15,000m max. (EH-OLNK,-OLNKG,E)
	Error station processing	Bypass system (coaxial), Bypass system (optical; only when supplying 5V DC from another power source)	
	Recommended cable (EH-LNK)	Coaxial cable with shield (equivalent to the 5D-2V with shield)	
	Recommended connector (EH-LNK)	Link module side: equivalent to 413631-1 (by AMP)	
	Recommended cable and connector (Refer to the instruction of each module for more details.)	EH-OLNK	CA7103 - [1]M - [2]L [3]1 Hitachi Hybrid Network Co., Ltd. [1]: cable length, [2]: cable type, [3]: core number
EH-OLNKG, EH-OLNKE		CA9103S - [1]M - AL11 Hitachi Hybrid Network Co., Ltd. CA9003S - [1]M - AL12 CA9103S - [1]M - [2]B [1]: cable length, [2]: core number For the recommended cable of EH-OLNKE, add "-625" at the end of above types.	
Mounting position	Slot 0 to 7 of basic base (max. 8 modules)		
Internal current consumption	550mA		

*1 Data is not retained for power failure.

2.10 Accessories

2.10.1 Dummy module: EH-DUM

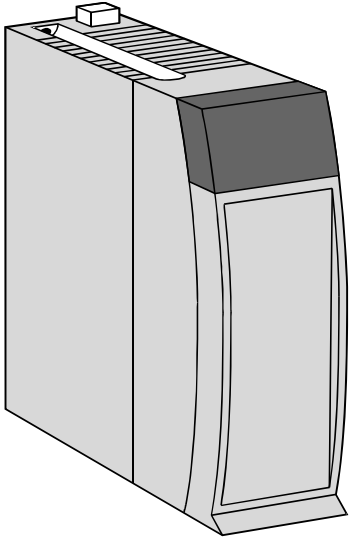
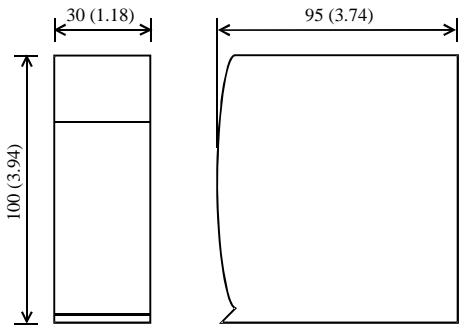
<p>Module features</p> 	<p>Type (Weight) EH-DUM (Approx. 0.06kg (0.132lb.))</p>
<p>Function</p>	<p>Dimensions (mm (in.))</p> 
<p>Function</p>	<p>This module is used for protecting the un-mounted slot.</p>

2.10.2 Expansion cable

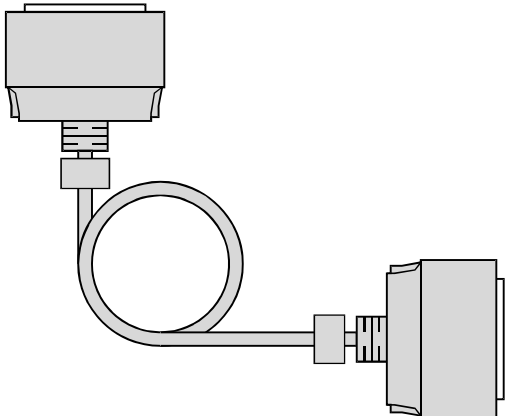
<p>Features</p> 	<p>Type EH-CB5A / 10A / 20A</p>
<p>Function</p>	<p>Weight Approx. 0.21 (0.46) / 0.24 (0.53) / 0.30 kg (0.66 lb.)</p> <p>Length 0.5 (1.64) / 1.0 (3.28) / 2.0 m (6.56 ft.)</p>
<p>Function</p>	<p>Connects to the expansion cable connector of the base unit and to the connector of the I/O controller. There is no directivity in the cable. Either connector can be connected to the base side.</p>

2.10.3 Relay terminal block for 32/64-point module

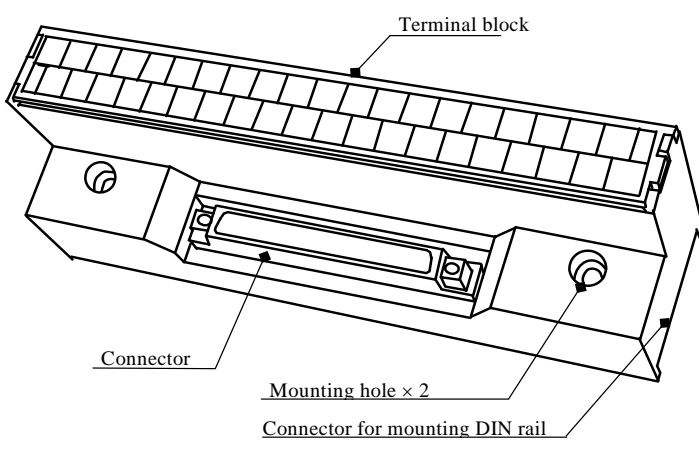
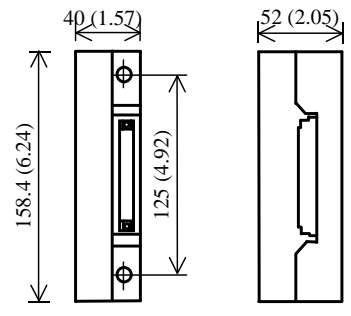
<p>Module features</p>  <p>Terminal block</p> <p>Connector</p> <p>Mounting hole × 2</p> <p>Connector for mounting DIN rail</p>		<p>Type (Weight)</p> <p>HPX7DS-40V6 (Approx. 0.22kg (0.049lb.))</p>
		<p>Dimensions (mm (in.))</p> 
Item	Description	
Terminal block	This is a terminal block for connecting the external wiring.	
Connector	This is a connector with 40 pins = 20 × 2 lines for connecting each module.	
Mounting hole	These holes are used when attaching the terminal unit to a panel. Use M4 × 25mm screws.	
Connector for mounting DIN rail	This is used when mounting attaching the terminal unit to the DIN rail.	

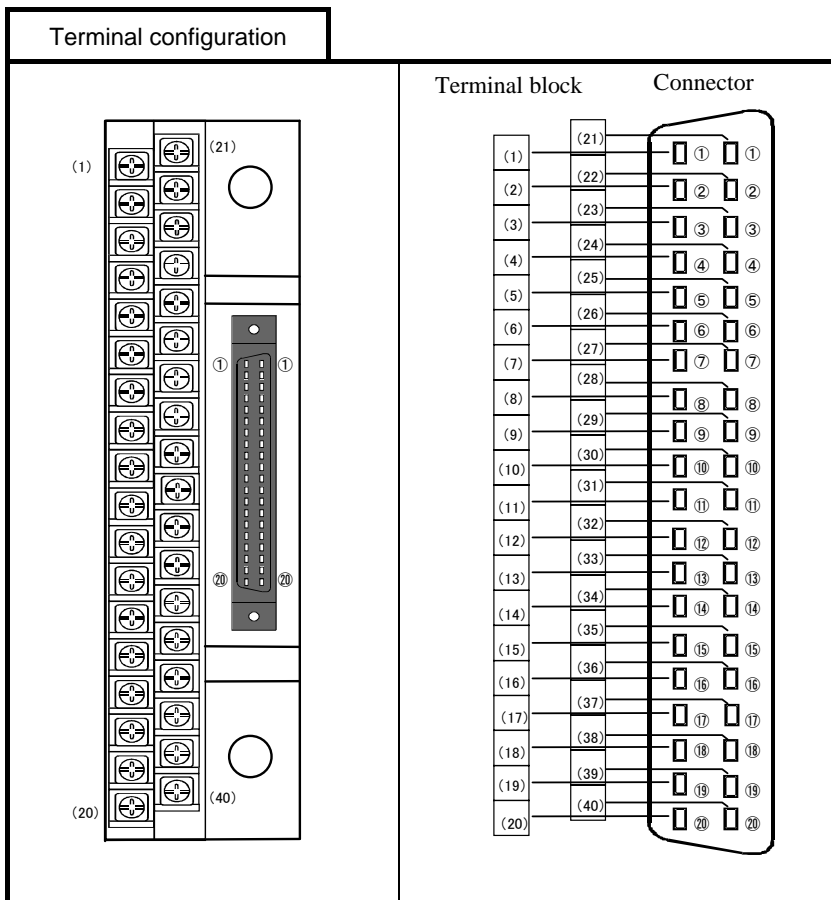

I/O and Terminal block							
EH-XD32				EH-YT32/YTP32			
I/O No. (Signal)	Terminal block No.	I/O No. (Signal)	Terminal block No.	I/O No. (Signal)	Terminal block No.	I/O No. (Signal)	Terminal block No.
X__00	1	X__16	21	Y__00	1	Y__08	21
X__01	2	X__17	22	Y__01	2	Y__09	22
X__02	3	X__18	23	Y__02	3	Y__10	23
X__03	4	X__19	24	Y__03	4	Y__11	24
X__04	5	X__20	25	Y__04	5	Y__12	25
X__05	6	X__21	26	Y__05	6	Y__13	26
X__06	7	X__22	27	Y__06	7	Y__14	27
X__07	8	X__23	28	Y__07	8	Y__15	28
C	9	C	29	C	9	C	29
X__08	10	X__24	30	S	10	S	30
X__09	11	X__25	31	Y__08	11	Y__24	31
X__10	12	X__26	32	Y__09	12	Y__25	32
X__11	13	X__27	33	Y__10	13	Y__26	33
X__12	14	X__28	34	Y__11	14	Y__27	34
X__13	15	X__29	35	Y__12	15	Y__28	35
X__14	16	X__30	36	Y__13	16	Y__29	36
X__15	17	X__31	37	Y__14	17	Y__30	37
C	18	C	38	Y__15	18	Y__31	38
N.C.	19	N.C.	39	C	19	C	39
N.C.	20	N.C.	40	S	20	S	40

In case the 64-point module, the signal No.00 to 31 depends on the table mentioned above. For signal No.32 to 63 (including COM), **read signal No.00 to 31 as signal No.32 to 63** in above table.

When using the 64-point module, 2 sets of the terminal block (HPX7DS-40V6) and the connection cable (EH-CBM**W) per a module are needed.

2.10.4 Cable for 32/64-point module

Features		Type (Length) (Both ends connector type) EH-CBM01W (1m (3.28ft.)) EH-CBM03W (3m (9.84ft.)) EH-CBM05W (5m (16.4ft.)) EH-CBM10W (10m (32.8ft.))			
			Type (Length) (open and connector end type) EH-CBM01 (1m (3.28ft.)) EH-CBM03 (3m (9.84ft.)) EH-CBM05 (5m (16.4ft.)) EH-CBM10 (10m (32.8ft.))		
				Diameter	AWG# 28
Item	Description				
Connector	This is a connector for connecting to the 32/64-point I/O module and the relay terminal block.				
Discrete wire	This is a discrete wire for wiring from the 32/64-point I/O module or the terminal unit.				
Earth terminal	Uses this terminal for class D grounding				

Cable code for wiring					
Connector Pin No.	Color	Dot (Color)	Connector Pin No.	Color	Dot (Color)
1	Orange	■(Black)	21	Orange	■ ■(Black)
2	Orange	□(Red)	22	Orange	□ □(Red)
3	Gray	■(Black)	23	Gray	■ ■(Black)
4	Gray	□(Red)	24	Gray	□ □(Red)
5	White	■(Black)	25	White	■ ■(Black)
6	White	□(Red)	26	White	□ □(Red)
7	Yellow	■(Black)	27	Yellow	■ ■(Black)
8	Yellow	□(Red)	28	Yellow	□ □(Red)
9	Pink	■(Black)	29	Pink	■ ■(Black)
10	Pink	□(Red)	30	Pink	□ □(Red)
11	Orange	■ ■(Black)	31	Orange	■ ■ ■(Black)
12	Orange	□ □(Red)	32	Orange	□ □ □(Red)
13	Gray	■ ■(Black)	33	Gray	■ ■ ■(Black)
14	Gray	□ □(Red)	34	Gray	□ □ □(Red)
15	White	■ ■(Black)	35	White	■ ■ ■(Black)
16	White	□ □(Red)	36	White	□ □ □(Red)
17	Yellow	■ ■(Black)	37	Yellow	■ ■ ■(Black)
18	Yellow	□ □(Red)	38	Yellow	□ □ □(Red)
19	Pink	■ ■(Black)	39	Pink	■ ■ ■(Black)
20	Pink	□ □(Red)	40	Pink	□ □ □(Red)

2.10.5 Cable for EM/H-200 series compatible 32-point module

<p>Features</p> <p>Connector for EM/H-200 series compatible 32-points I/O module</p> <p>Discrete wire</p> <p>Earth wire (Length: 1m (3.28ft.))</p>	Type (Length)	CBM-02 (2m (6.56ft.))
	(One edge connector type)	CBM-05 (5m (16.4ft.)) CBM-10 (10m (32.8ft.))
Diameter	AWG# 28	
Item	Description	
Connector	This is a connector for connecting to the EM/H-200 series compatible 32-point I/O module.	
Discrete wire	This is a discrete wire for wiring from the EM/H-200 series compatible 32-point I/O module.	
Earth wire	Uses this wire for class D grounding	

Cable code for wiring							
Terminal No.	Color of insulator	Dot mark	Color of Dot	Terminal No.	Color of insulator	Dot mark	Color of Dot
1	White	■ ■ ■	Black	26	Pink	■ ■ cont. ■ ■	Red
2	Gray	■ ■ ■	Red	27	Pink	■ ■ cont. ■ ■	Black
3	Gray	■ ■ ■	Black	28	Yellow	■ ■ cont. ■ ■	Red
4	Orange	■ ■ ■	Red	29	Yellow	■ ■ cont. ■ ■	Black
5	Orange	■ ■ ■	Black	30	White	■ ■ cont. ■ ■	Red
6	Pink	■ ■	Red	31	White	■ ■ cont. ■ ■	Black
7	Pink	■ ■	Black	32	Gray	■ ■ cont. ■ ■	Red
8	Yellow	■ ■	Red	33	Gray	■ ■ cont. ■ ■	Black
9	Yellow	■ ■	Black	34	Orange	■ ■ cont. ■ ■	Red
10	White	■ ■	Red	35	Orange	■ ■ cont. ■ ■	Black
11	White	■ ■	Black	36	Pink	■ ■ ■ ■	Red
12	Gray	■ ■	Red	37	Pink	■ ■ ■ ■	Black
13	Gray	■ ■	Black	38	Yellow	■ ■ ■ ■	Red
14	Orange	■ ■	Red	39	Yellow	■ ■ ■ ■	Black
15	Orange	■ ■	Black	40	White	■ ■ ■ ■	Red
16	Pink	■	Red	41	White	■ ■ ■ ■	Black
17	Pink	■	Black	42	Gray	■ ■ ■ ■	Red
18	Yellow	■	Red	43	Gray	■ ■ ■ ■	Black
19	Yellow	■	Black	44	Orange	■ ■ ■ ■	Red
20	White	■	Red	45	Orange	■ ■ ■ ■	Black
21	White	■	Black	46	Pink	■ ■ ■	Red
22	Gray	■	Red	47	Pink	■ ■ ■	Black
23	Gray	■	Black	48	Yellow	■ ■ ■	Red
24	Orange	■	Red	49	Yellow	■ ■ ■	Black
25	Orange	■	Black	50	White	■ ■ ■	Red

2.10.6 Cable for counter input module

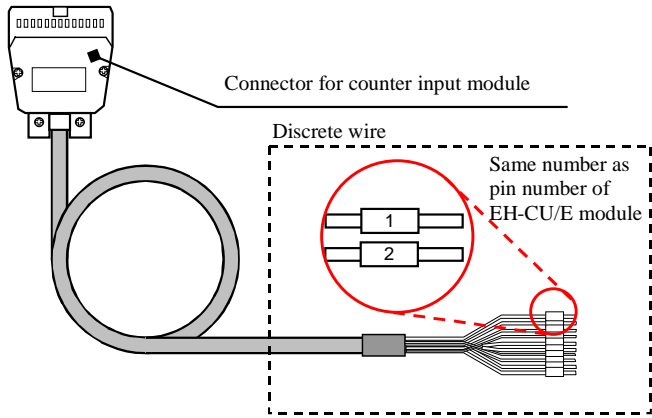
Features		Type (Length) (One edge connector type)	EH-CUC01 (1m (3.28ft.))
 <p>Connector for counter input module</p> <p>Discrete wire</p> <p>Same number as pin number of EH-CU/E module</p>		EH-CUC02 (2m (6.56ft.))	
		EH-CUC03 (3m (9.84ft.))	
		EH-CUC04 (4m (13.1ft.))	
		EH-CUC05 (5m (16.4ft.))	
		Diameter	AWG# 24
Item	Description		
Connector	This is a connector for connecting to the counter input module.		
Discrete wire	This is a discrete wire for wiring from the counter input module.		

2.10.7 Serial communication cable between PC and PLC

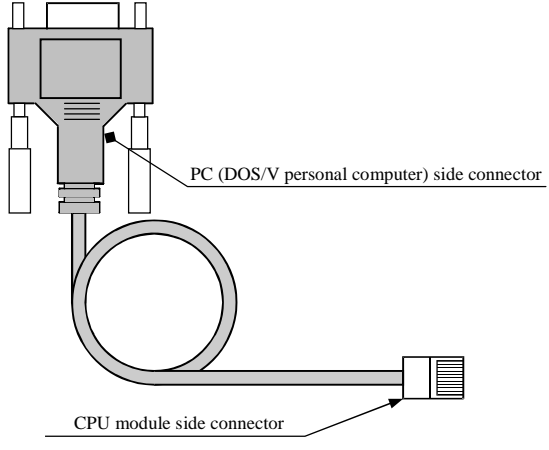
Features		Type (Weight)	EH-VCB02 (Approx.0.13kg (0.29lb.))
 <p>PC (DOS/V personal computer) side connector</p> <p>CPU module side connector</p>		Length	2.0 m (6.56ft.)
		Function	Serial communication cable between PC and CPU.

2.10.8 Others

Product	Type	Specification
Lithium battery	LIBAT-H	For retentive data and real time clock. Commonly used in H/EH series

MEMO

Chapter 3 Programming

3.1 Installation

3.1.1 Installation of CODESYS/EHV-CODESYS

1. The installation wizard starts up automatically on EHV-CODESYS installation CD.
2. Follow the instructions

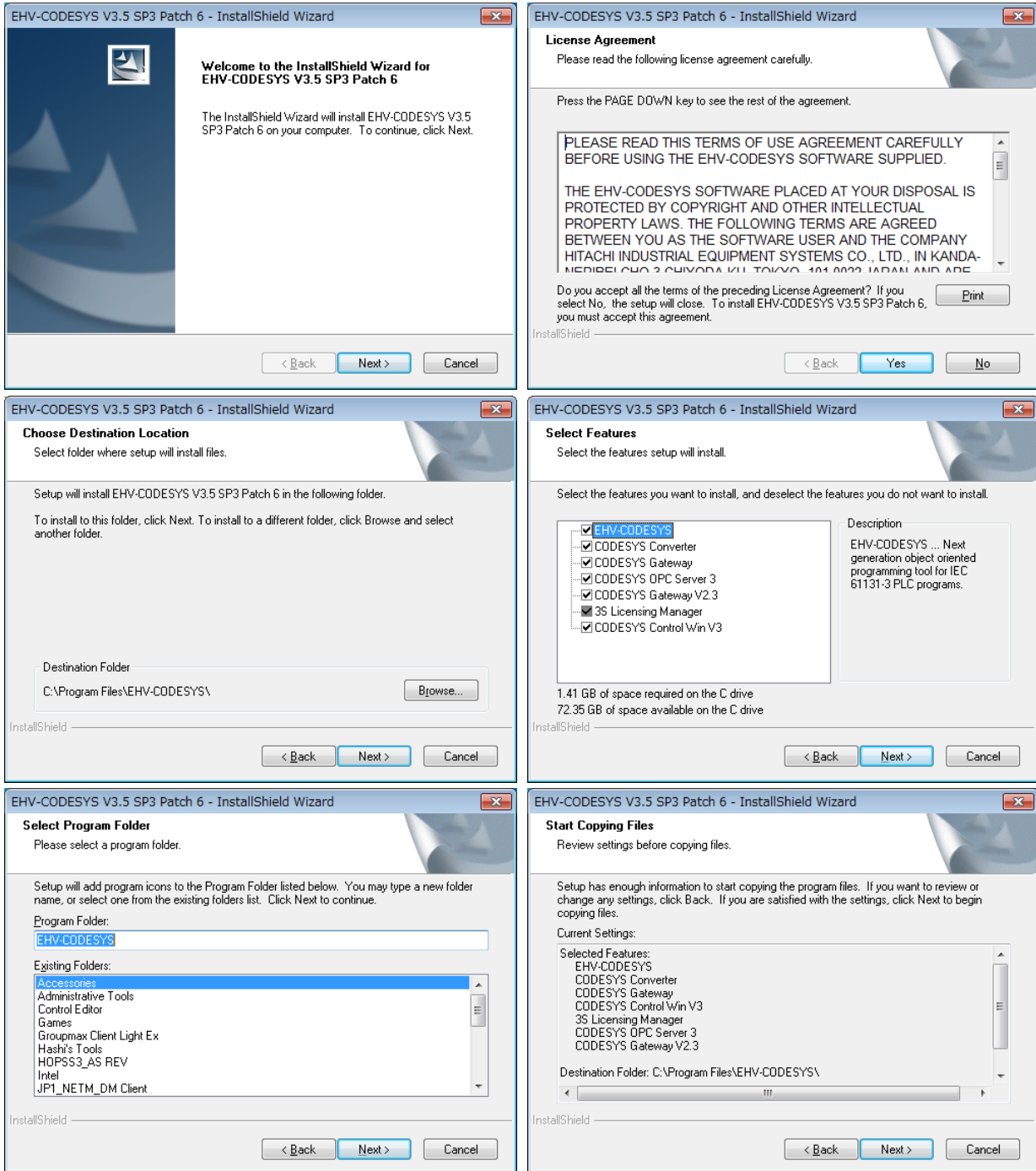

Note

Several Microsoft components are necessary to be installed for EHV-CODESYS. If components are not installed in your PC, the installation of EHV-CODESYS stops and a dialog appears. Click [Install] at the dialog to extract from setup file.

3.1.2 Installation of USB driver

1. Plug in USB cable to CPU module.
2. Popup window appears at right-bottom of screen. Click the popup window.

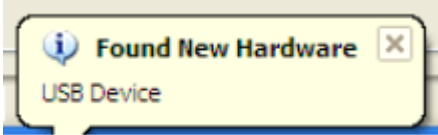

3. Click “Install from a list or specific location (Advanced)” and “Next” button.



4. Click “Include this location in the search” with the path C:\Program Files\EHV-CODESYS\GatewayPLC\Driver and “Next” button. USB driver for Windows 7 64-bit is in the separated folder as below.

- x64 ... Windows 7 64-bit
- x86 ... Windows 2000, Windows XP, Windows Vista, Windows 7 32-bit

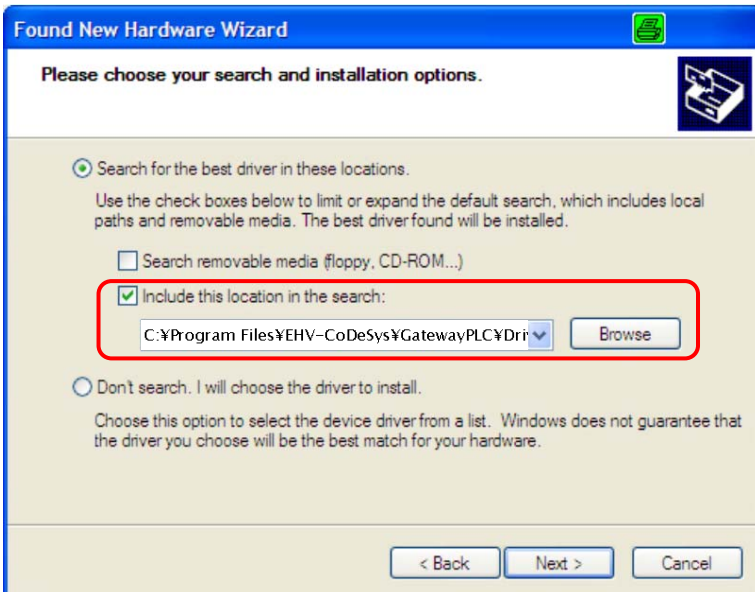

5. USB driver installation is in progress.

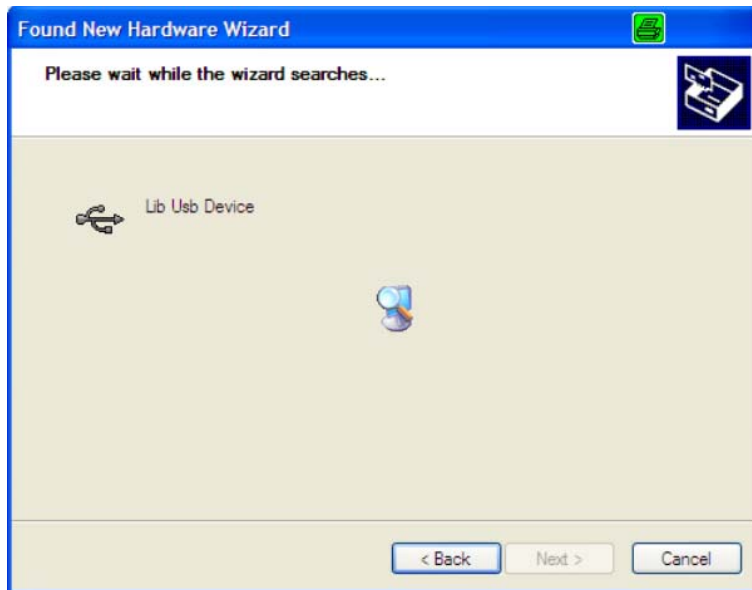

6. USB driver installation has been completed. Click “Finish” to close the wizard.



7. Reboot the PC to activate the USB driver.

Note

As of Nov. 2015, the latest version of CODESYS is V3.5 SP7 and the latest version of EHV-CODESYS is V3.5 SP3 Patch6 however, CODESYS V3.5 SP5 or newer version is required for CPU V3.5. For this reason, several screen shots in this manual are taken by standard CODESYS V3.5 SP5. Please be noted some dialogs in this manual may be slightly different from your CODESYS/EHV-CODESYS.

3.2 Startup

In the first use, you need to specify the type of development activity “Standard” or “Professional” you engage in the most.

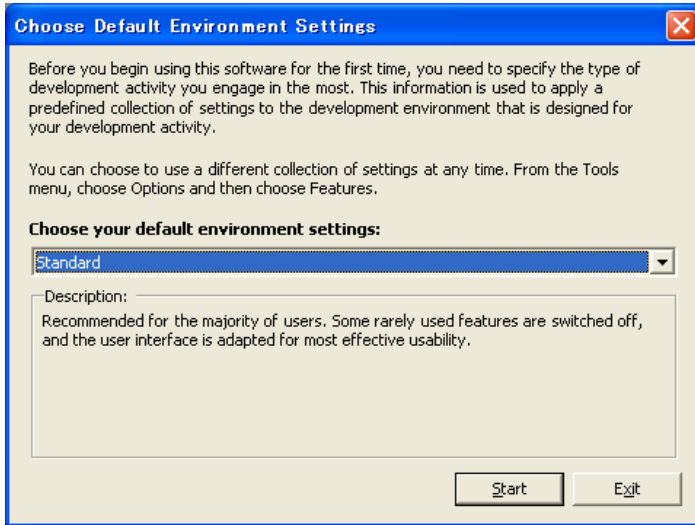

Although the above dialog appears at the first use only, this setting can be changed later in the menu [Tools]-[Options]-[Features] as below.

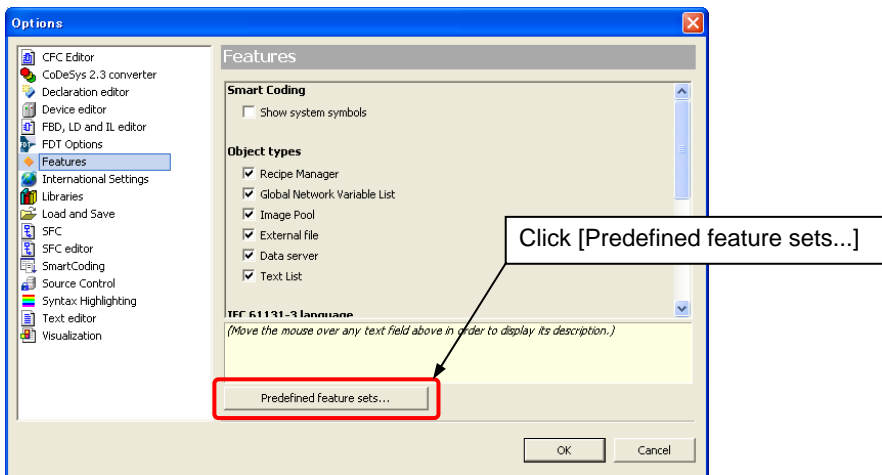

Click  icon or choose [File]-[New Project...] to create a new project file. Then New Project dialog box appears as below. Choose “Standard project”, enter new file name, specify location and click [OK].

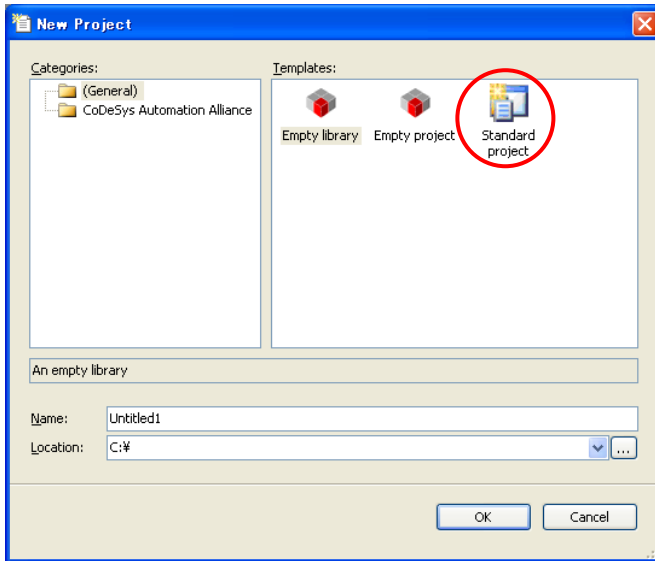

Choose CPU type and programming language and click [OK].

Available languages are as follows.

- Continuous Function Chart (CFC)
- Function Block Diagram (FBD)
- Instruction List (IL)
- Ladder Logic Diagram (LD)
- Sequential Function Chart (SFC)
- Structured Text (ST)

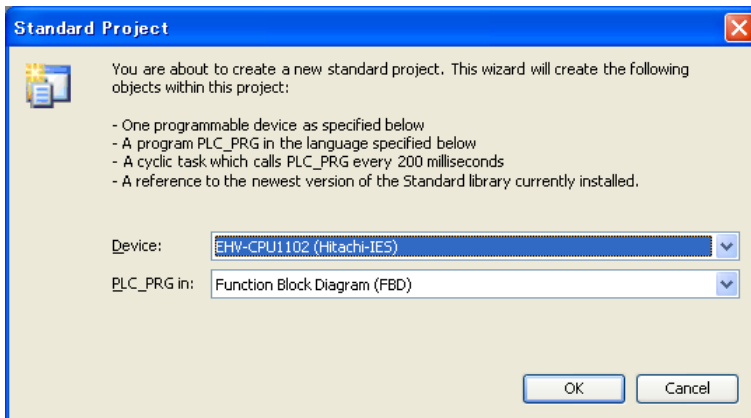

Initial screen shot of EHV-CODESYS is shown below.

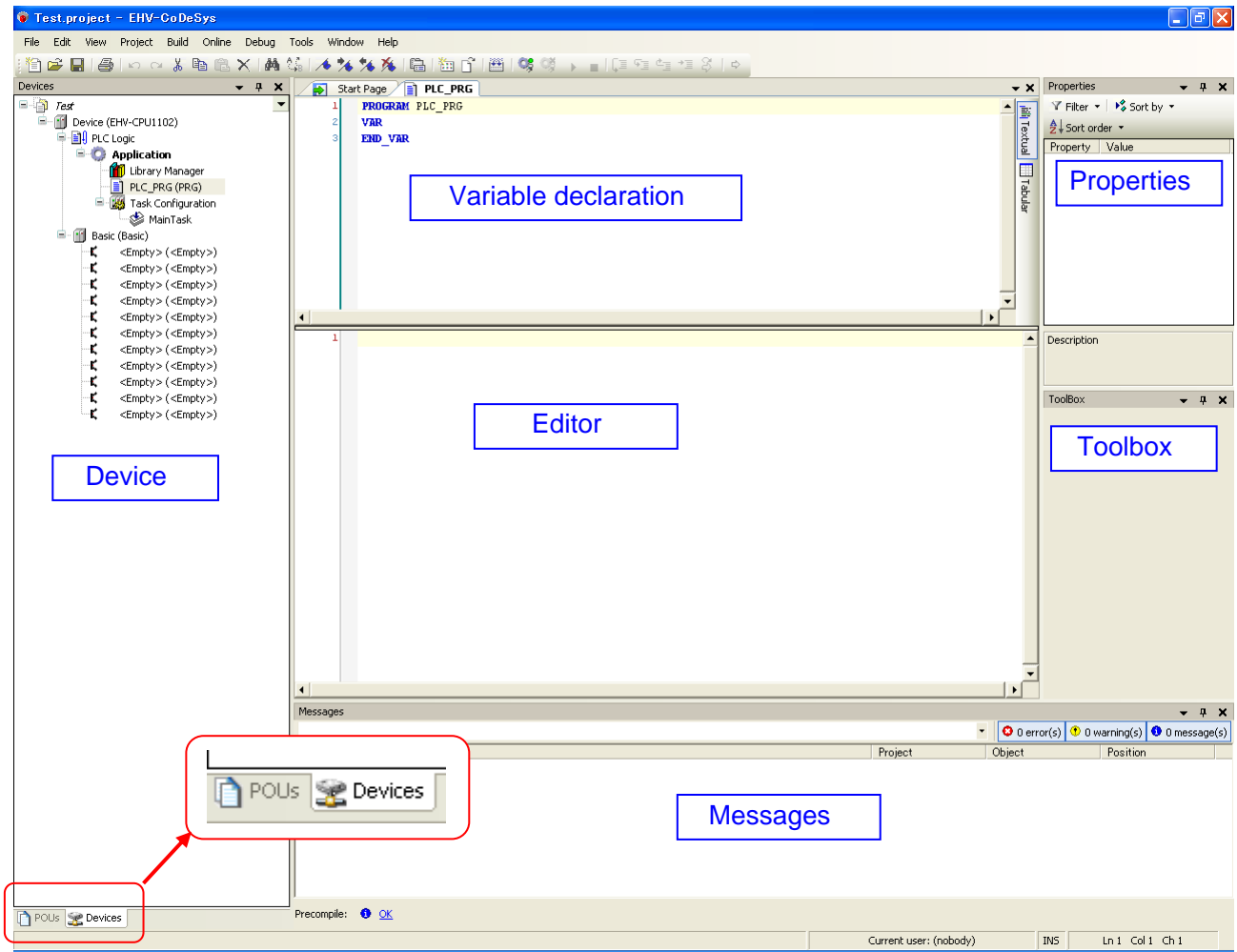

In the default setting, Device tree is behind the POU window. Click Devices tab to show it. "Toolbox" and "Properties" windows can be shown by [View] menu.

3.3 I/O Configuration

3.3.1 Plug Device (I/O configuration)

Right click on <Empty> slot and choose “Plug Device...”.

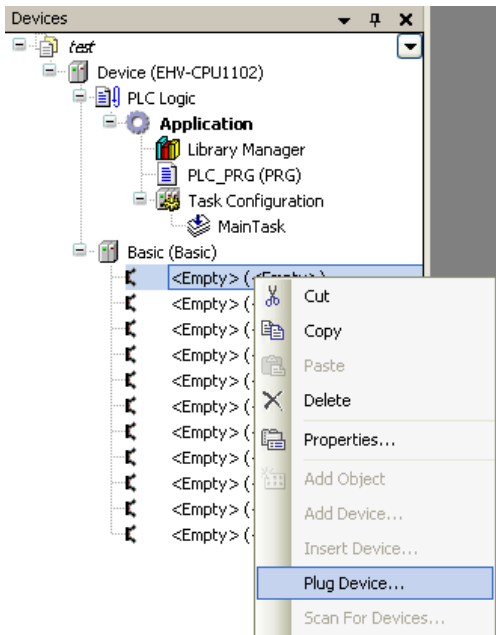

Choose I/O module for each slot. The next slot can be configured by clicking next empty slot without closing the Plug Device window every time.

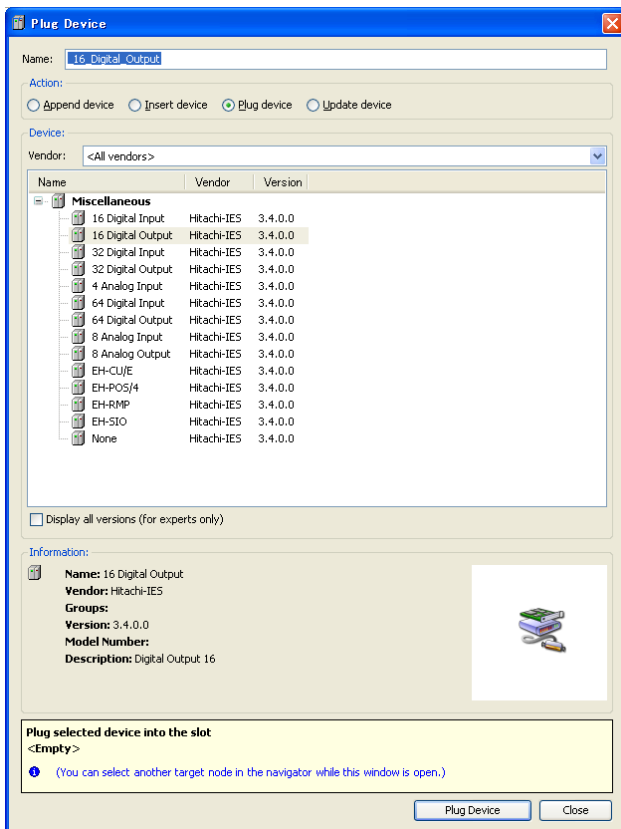

Module name can be renamed at “Properties” in right mouse click menu.

_16_Digital_Output (16 Digital Output)



Any_Name (16 Digital Output)

Configure I/O modules according to the list below.

Model names	Device Names
EH-XD8, 16, L16, S16	16 Digital input
EH-XA16, H16	
EH-XD32, L32, S32, 32E, L32E, 32H	32 Digital input
EH-XD64	64 Digital input
EH-YR8B, 12, 16, 16D	16 Digital output
EH-YT8, 16	
EH-YTP8, 16, 16S	
EH-YS4, 16	
EH-YT32, 32E, 32H	32 Digital output
EH-YTP32, 32E	
EH-YT64	64 Digital output
EH-YTP64	
EH-PT4	4 Analog input
EH-RTD8 (PT4 compatible mode)	8 Analog input
EH-AX44, 8V, 8H, 8I, 8IO	
EH-AXH8M, EH-AXG5M	
EH-RTD8 (standard mode)	
EH-TC8	
EH-AY22, 2H, 4V, 4H, 4I *1	8 Analog output
EH-AYH8M, EH-AYG4M	
EH-CU, CUE	EH-CU/E
EH-POS	EH-POS/4
EH-RMP/2	EH-RMP (CPU ROM VER.3.4.1.3 or older)
EH-RMP/2, RMD, LNK, OLNK, OLNKE, OLNKG	EH-LNK (CPU ROM VER.3.4.4.0 or newer)
EH-SIO	EH-SIO

*1 Although the number of channel is not 8, configure “8 ch. Analog output”.

3.3.2 Scan For Devices

Instead of plugging I/O modules one by one, actual I/O module information can be read out from connected CPU.

Right click on basic or expansion base and choose “Scan For Devices...”. Then “Scan Devices” dialog appears. Click “Copy all devices to project”. This function works for chosen base only. If you have several expansion bases, repeat “Scan For Device” for each base.

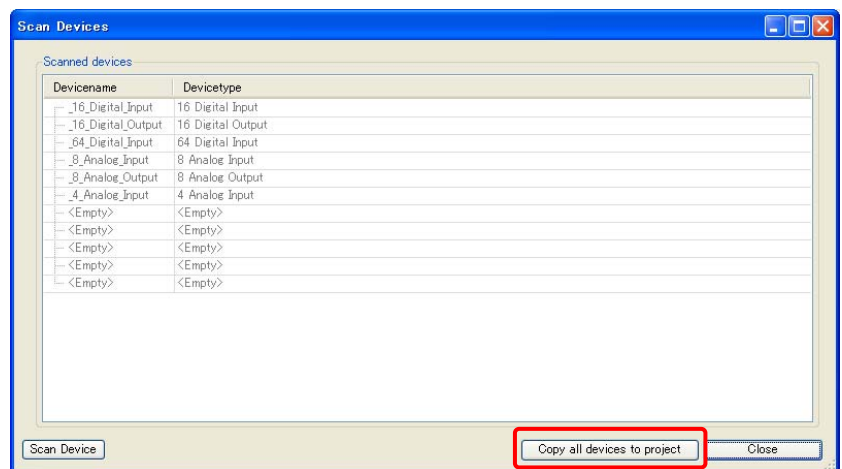
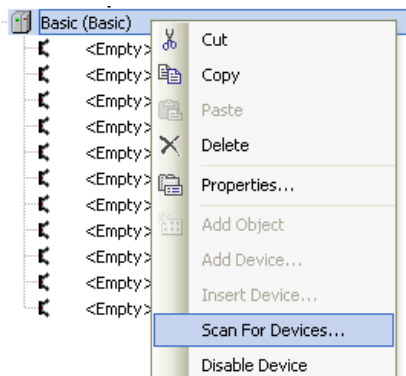

Note

Be sure to perform “Scan For Devices” after login and logout. “Scan For Devices” works only when logout however, gateway and active path must be set and opened once in advance.

3.3.3 Expansion unit

Instead of “Plug Device”, choose “Add Device” to configure expansion units.

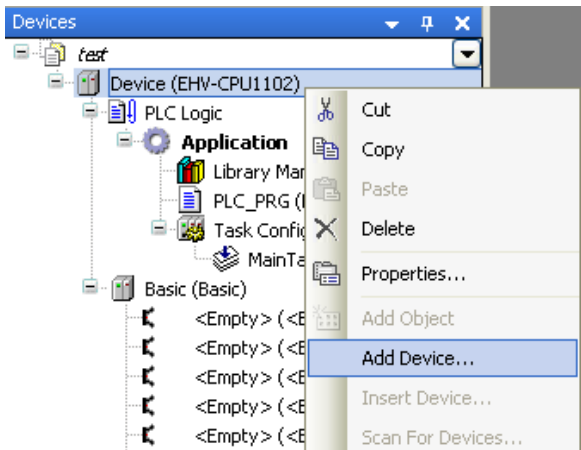

EHV-CPU1025 to CPU1102 allows to expand up to 5 expansion bases. The low end type “EHV-CPU1006” is not expandable.

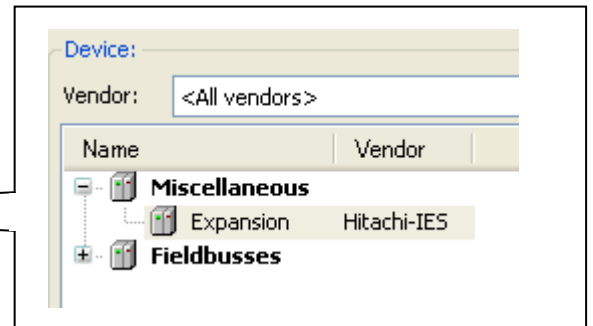
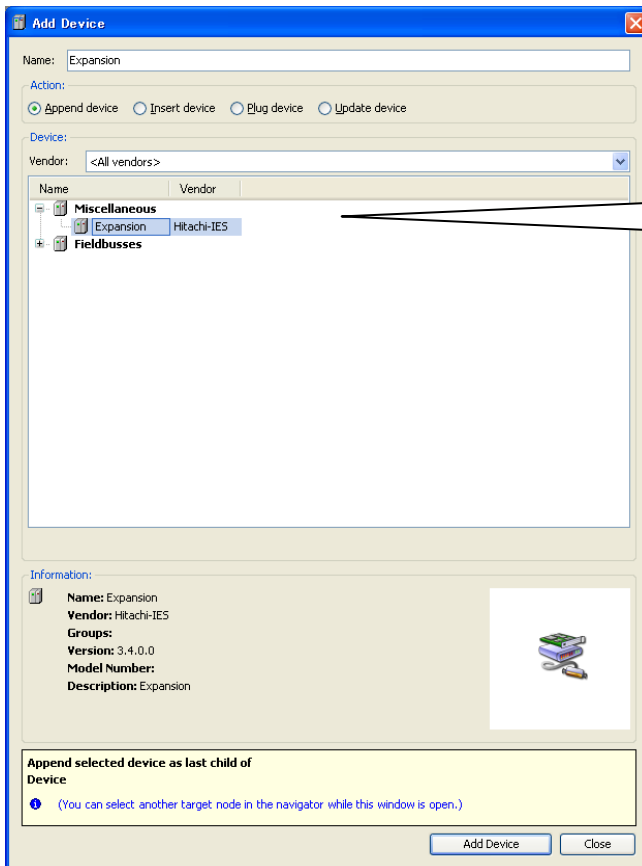

3.3.4 Update Device

Although device (CPU) type is required to set when creating new project, it can be changed later.

Right mouse click on the device and choose “Update Device”. Then “Update Device” windows appears.

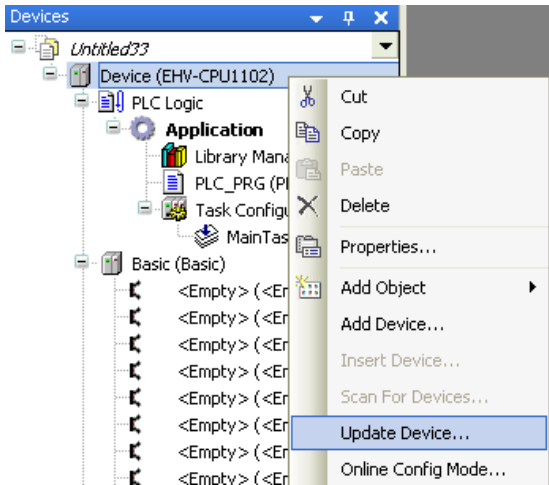

Choose one of the devices and click [Update Device] button. If CPU ROM VER.3.4.1.3 or older is used, click at “Display all versions (for experts only)” and choose the device version 3.4.1.2 or older. Refer to the section 3.22 Notes for Ver.3.5 SP3 for further information.

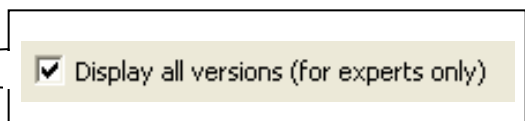
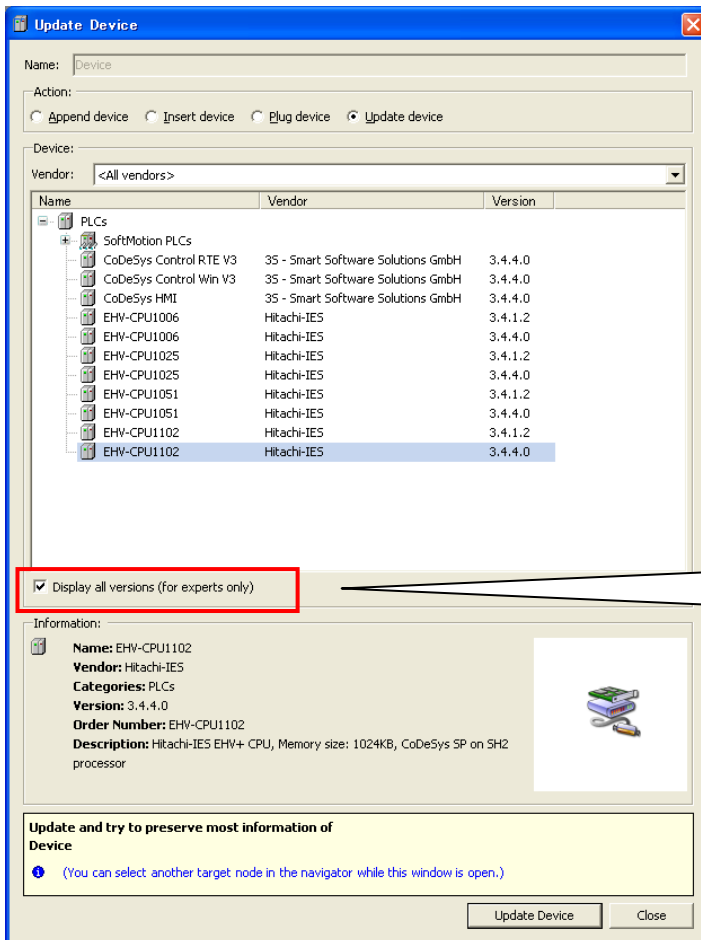

Note

“Display all versions (for experts only)” is displayed in professional mode only. If you use standard mode, please switch to professional mode by choosing [Tool] – [Options] as shown in the section 3.2 Startup.

3.3.5 I/O address

I/O addresses and variable names can be linked in two different ways: Global variable or Local variable as below.

[Global variable]

Double click on plugged I/O module or right click and choose “Edit Object”.

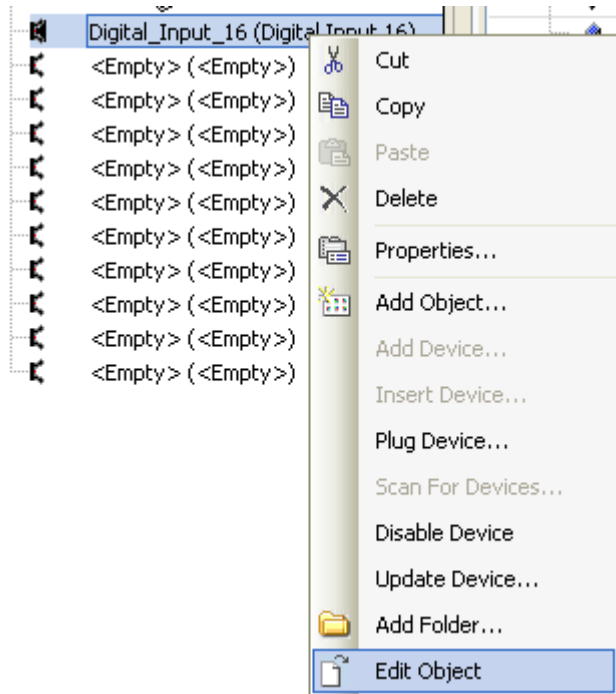

I/O-Bus Mapping window appears as below. Due to Motorola type byte order of SH-2 processor, IEC address of 16-bit data starts from 1.0 and ends to 0.7 as follows. Since the bit number shown at “Channel” corresponds to actual signal number, put variable names according to the bit number.

Variable	Mapping	Channel	Address	Type	Current Value	Default Va...	Unit	Description
		Reserve Word 0	%IW0	WORD				Reserve Word 0
		Bit0	%IX1.0	BOOL		FALSE		
		Bit1	%IX1.1	BOOL		FALSE		
		Bit2	%IX1.2	BOOL		FALSE		
		Bit3	%IX1.3	BOOL		FALSE		
		Bit4	%IX1.4	BOOL		FALSE		
		Bit5	%IX1.5	BOOL		FALSE		
		Bit6	%IX1.6	BOOL		FALSE		
		Bit7	%IX1.7	BOOL		FALSE		
		Bit8	%IX0.0	BOOL		FALSE		
		Bit9	%IX0.1	BOOL		FALSE		
		Bit10	%IX0.2	BOOL		FALSE		
		Bit11	%IX0.3	BOOL		FALSE		
		Bit12	%IX0.4	BOOL		FALSE		
		Bit13	%IX0.5	BOOL		FALSE		
		Bit14	%IX0.6	BOOL		FALSE		
		Bit15	%IX0.7	BOOL		FALSE		

Input any variable names in the field “Variable” according to your system.

Test_input_0		Bit0	%IX1.0	BOOL
Test_input_1		Bit1	%IX1.1	BOOL
		Bit2	%IX1.2	BOOL
		Bit3	%IX1.3	BOOL

Variable	Mapping	Channel	Address	Type	Default Va...	Unit	Description
		Reserve Word 0	%IW0	WORD			Reserve Word 0
Test_input_0		Bit0	%IX1.0	BOOL	FALSE		
Test_input_1		Bit1	%IX1.1	BOOL	FALSE		
Test_input_2		Bit2	%IX1.2	BOOL	FALSE		
Test_input_3		Bit3	%IX1.3	BOOL	FALSE		
Test_input_4		Bit4	%IX1.4	BOOL	FALSE		
Test_input_5		Bit5	%IX1.5	BOOL	FALSE		
Test_input_6		Bit6	%IX1.6	BOOL	FALSE		
Test_input_7		Bit7	%IX1.7	BOOL	FALSE		
Test_input_8		Bit8	%IX0.0	BOOL	FALSE		
Test_input_9		Bit9	%IX0.1	BOOL	FALSE		
Test_input_10		Bit10	%IX0.2	BOOL	FALSE		
Test_input_11		Bit11	%IX0.3	BOOL	FALSE		
Test_input_12		Bit12	%IX0.4	BOOL	FALSE		
Test_input_13		Bit13	%IX0.5	BOOL	FALSE		
Test_input_14		Bit14	%IX0.6	BOOL	FALSE		
Test_input_15		Bit15	%IX0.7	BOOL	FALSE		

After defining variable names, they will be automatically listed up when it is used in all POU with assist of auto-complete.

If a variable is already used (declared) in POU or global variable list, it can be taken by clicking icon in I/O mapping window. (icon appears by clicking empty field.)

Application.GVL.EMG_STOP		Bit0
Application.PLC_PRG.test_out		Bit1

[Local variable]

Local variables are defined in each POU and valid only in the POU.

If new variable name is used in the first time, Auto Declare window will appear as below. In this window, there is an input field “Address”. Enter I/O address in this field according to data types. If it is remained as blank, the variable will be mapped in memory area.

After clicking [OK] button, declared information is added automatically as below.

```

1  PROGRAM PLC_PRG
2  VAR
3      test_input_0 AT %IX1.0: BOOL;
4      test_output_0 AT %QX1.0: BOOL;
5  END_VAR

```

I/O address example of 64 points output module

Bit number	BOOL	BYTE	WORD	DWORD	LWORD	
Bit 0	%QX7.0	%QB7	%QW3	%QD1	%QL0	<div style="text-align: center;"> ↑ LSB </div>
Bit 1	%QX7.1					
Bit 2	%QX7.2					
Bit 3	%QX7.3					
Bit 4	%QX7.4					
Bit 5	%QX7.5					
Bit 6	%QX7.6					
Bit 7	%QX7.7					
Bit 8	%QX6.0	%QB6	%QW2			
Bit 9	%QX6.1					
Bit 10	%QX6.2					
Bit 11	%QX6.3					
Bit 12	%QX6.4					
Bit 13	%QX6.5					
Bit 14	%QX6.6					
Bit 15	%QX6.7					
Bit 16	%QX5.0	%QB5	%QW1	%QD0		
Bit 17	%QX5.1					
Bit 18	%QX5.2					
Bit 19	%QX5.3					
Bit 20	%QX5.4					
Bit 21	%QX5.5					
Bit 22	%QX5.6					
Bit 23	%QX5.7					
Bit 24	%QX4.0	%QB4	%QW0			
Bit 25	%QX4.1					
Bit 26	%QX4.2					
Bit 27	%QX4.3					
Bit 28	%QX4.4					
Bit 29	%QX4.5					
Bit 30	%QX4.6					
Bit 31	%QX4.7					
Bit 32	%QX3.0	%QB3	%QW0			
Bit 39	%QX3.7					
Bit 40	%QX2.0	%QB2	%QW0			
Bit 47	%QX2.7					
Bit 48	%QX1.0					
Bit 55	%QX1.7	%QB1	%QW0			
Bit 56	%QX0.0					
Bit 63	%QX0.7					
		%QB0	%QW0			
Bit 56	%QX0.0					
Bit 63	%QX0.7					<div style="text-align: center;"> ↓ MSB </div>

Following 5 different codes access the same bit.

- %QX7.0:=1;
- %QB7 :=1;
- %QW3 :=1;
- %QD1 :=1;
- %QL0 :=1;

3.4 I/O-update

Input data is read at the beginning of a task and output data is written at the end of a task. I/O-update settings are configured in “PLC settings” in Device tab. Be noted that only used I/Os in program are updated.

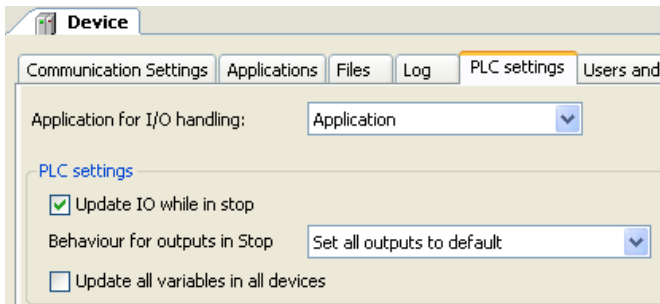

Update IO while in stop

If this option is activated (default), the values of the input and output channels get also updated when the PLC is stopped.

Behaviour for outputs in Stop

Keep current values: The current values will not be modified. If “Update IO while is stop” is deactivated, output data is not updated at CPU stopping.

Set all outputs to default: The default values resulting from the mapping will be assigned. If this setting is used, “Reset all outputs in STOP” of [Device]-[Configurtion] parameter must be set as “No”, otherwise default value of TRUE is not valid. Refer to the next page for further information.

Execute program: You might determine the outputs behaviour by a program available within the project. Enter the name of this program here and it will be executed when the PLC gets stopped. Via button [...] the input Assistant can be used for this purpose.

Update all variables in all devices

If this option is activated, then for all devices of the current PLC configuration all I/O variables will get updated in each cycle of the bus cycle task. This corresponds to option “Always update variables”, which can be set separately for each device in the "I/O Mapping" dialog.

Note

If all the following conditions are fulfilled and reset warm/cold is operated, the last status of output module remains although monitored output status is reset.

- Update IO while in stop in PLC settings: Disabled
- Behavior for outputs in Stop in PLC settings: Keep current values
- Reset all outputs in STOP in Device Configuration: No
- Variable of output module is mapped to existing variable that declared in POU or GVL.

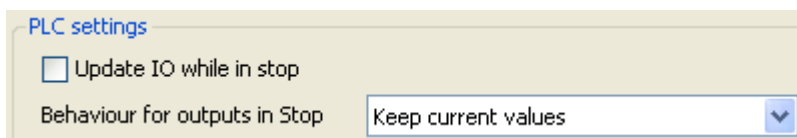

Actual output remains after Reset warm/cold

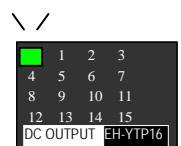
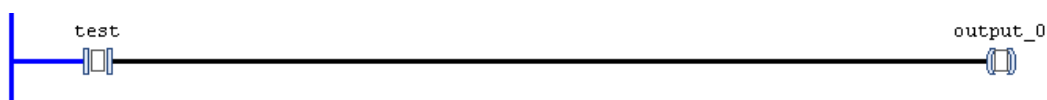

This is expected behaviour. If this setting combination is required, keep in mind this mismatching and be careful to use.

Reset all outputs in STOP

This setting is in [Device]-[Configuration]. If “Reset all outputs in STOP” is “Yes” (default), all the PLC outputs including counter outputs and pulse train output of positioning module are reset because it is reset by a certain hardware signal running on the back plane bus. If default value in configured as TRUE in I/O mapping table, it is momentary reset (FALSE) at run or stop timing. If default values should be kept, set “Reset all outputs in STOP” as “No.” In this case, you must be aware following limitation.

Note

If “Reset all outputs in STOP” is “No”, PLC outputs without IEC address, such as counter outputs or pulse train outputs, are NOT reset when CPU stops. We recommend you to set “Yes” when using counter or positioning modules.

Parameter	Type	Value	Default Value
IP Address	STRING	'192.168.0.1'	'192.168.0.1'
Subnet Mask	STRING	'255.255.255.0'	'255.255.255.0'
Default Gateway	STRING	'0.0.0.0'	'0.0.0.0'
Ethernet port Link speed / Duplex mode	Enumeration of BYTE	Auto Negotiation	Auto Negotiation
Change IP information	Enumeration of BYTE	No	No
Serial port mode	Enumeration of BYTE	IEC programming	IEC programming
Serial port type	Enumeration of BYTE	RS-232C	RS-232C
Serial port term. resistor (RS-422/485)	Enumeration of BYTE	No	No
Reset all outputs in STOP	Enumeration of BYTE	Yes	Yes
Stop switch definition	Enumeration of BYTE	Reset warm	Reset warm
External PHY Clock	Enumeration of BYTE	Yes	Yes

Note

If “Reset all outputs in STOP” is “Yes” (default), default value of “TRUE” in I/O mapping table is momentary reset (FALSE) at run or stop timing.

The screenshot shows the '16 Digital Output I/O Mapping' window with 'Information' and 'Status' tabs. The 'Channels' section contains a table with the following data:

Variable	Mapping	Channel	Address	Type	Default Value	Unit
			%QW0	WORD		
		Bit0	%QX1.0	BOOL	FALSE	
		Bit1	%QX1.1	BOOL	FALSE	
		Bit2	%QX1.2	BOOL	FALSE	
		Bit3	%QX1.3	BOOL	FALSE	
		Bit4	%QX1.4	BOOL	FALSE	
		Bit5	%QX1.5	BOOL	FALSE	
		Bit6	%QX1.6	BOOL	FALSE	
		Bit7	%QX1.7	BOOL	FALSE	
		Bit8	%QX0.0	BOOL	FALSE	
		Bit9	%QX0.1	BOOL	FALSE	
		Bit10	%QX0.2	BOOL	FALSE	
		Bit11	%QX0.3	BOOL	FALSE	
		Bit12	%QX0.4	BOOL	FALSE	
		Bit13	%QX0.5	BOOL	FALSE	
		Bit14	%QX0.6	BOOL	FALSE	
		Bit15	%QX0.7	BOOL	FALSE	

3.5 POU and task

One application has at least one POU and one task as shown below.

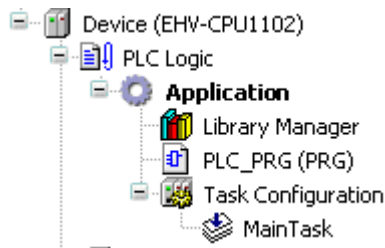

POU

POU stands for Program Organization Unit. This can be assumed as a paper to create your program. Only one programming language can be used in one POU. If you need another language, add POU by right click on “Application” and choose “Add object”-“POU” and choose language.

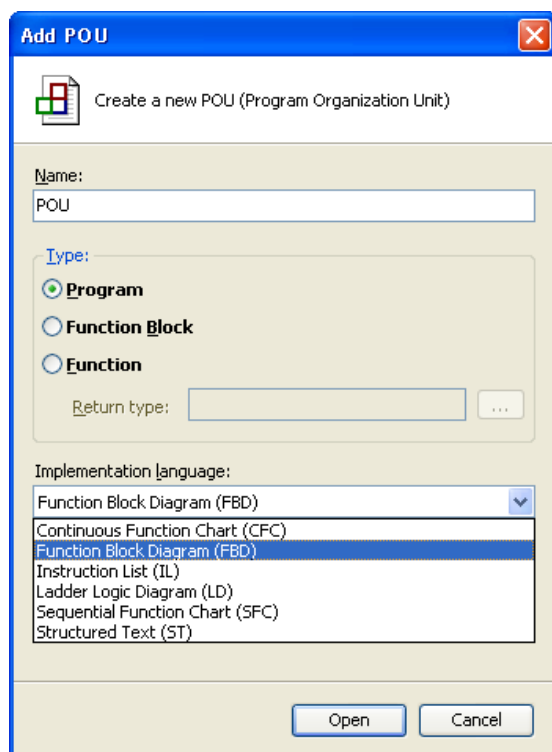
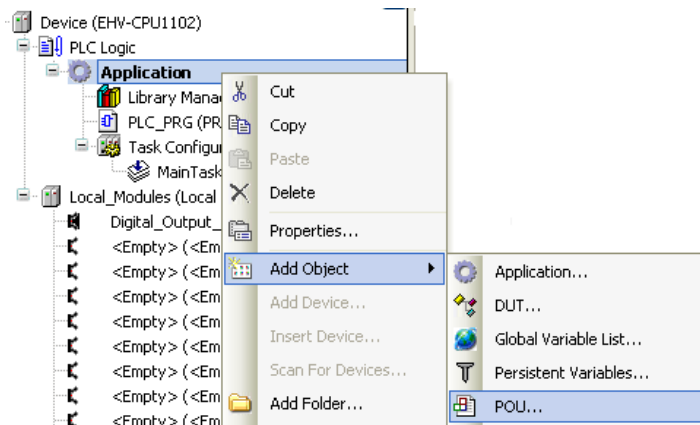

Task

POU does not have information how it is executed. This information is handled by task.

Put priority, choose type of task and add or remove POU accordingly.

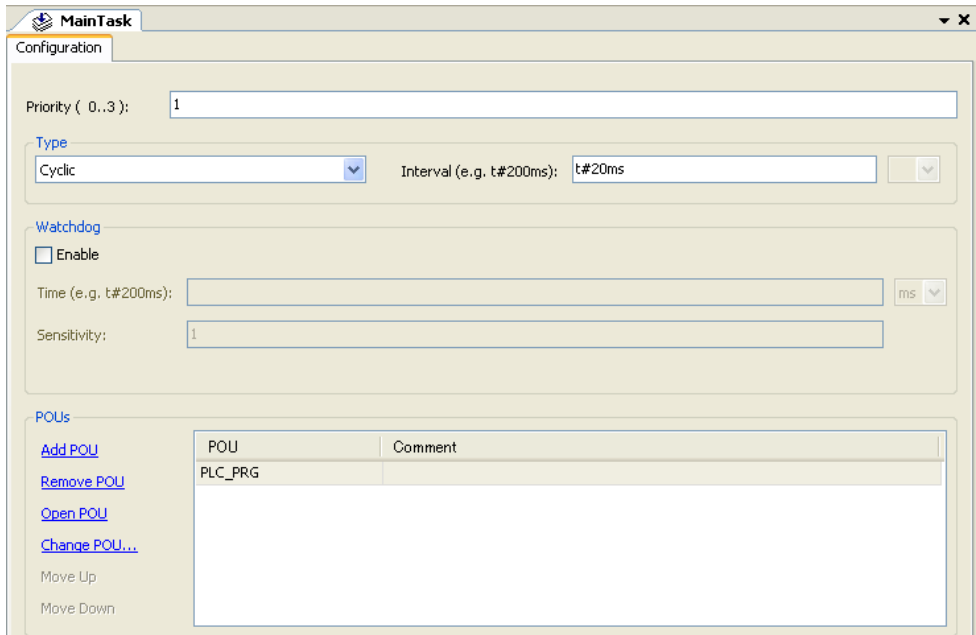

Priority (0-3)

0 is the highest priority, 3 is the lowest.

Cyclic task

The task will be processed cyclic according to the time definition given in the field “Interval”.

Event task

The task will be started as soon as the variable defined in the field gets a rising edge.

External task (CPU V3.4)

The task will be started as soon as the system event occurs. The CPU supports two tasks as below.

ApplicationStart: This task is executed at once just after CPU starting.

ApplicationStop: This task is executed at once just after CPU stopping.

Freewheeling task

The task will be processed as soon as the program is started and at the end of one run will automatically restarted in a continuous loop. There is no cycle time defined. Be noted that the priority of this task is the lowest and 100ms of sleeping time is added at the end of each cycle for other tasks to be executed properly.

Watchdog

When it is enabled, watchdog function is activated. If program execution time exceeds watchdog time, CPU stops program execution with exception status.

Actual cycle time of each task is monitored in Task configuration as below.

Task	Status	IEC-Cycle Count	Cycle Count	Last Cycle Time (µs)	Average Cycle Time (µs)	Max. Cycle Time (µs)	Min. Cycle Time (µs)
MainTask	Valid	1926	2118	2000	1840	3000	2000

Event Handler (CPU V3.5)

Event Handler function has been available since CODESYS V3.5. This can be used instead of External task (ApplicationStart/Stop) for V3.4.

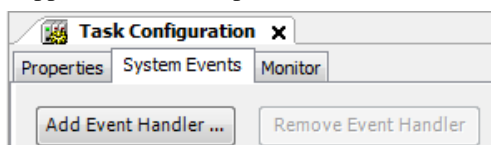

3.6 Variables

3.6.1 Data memory

In EHV-CODESYS programming, external I/Os and data memory (internal registers) are handled as variable names instead of direct I/O addresses, such like “A1_switch”. If new variable name is used, below Auto Declare window appears. Enter an each field according to following table.

Item	Descriptions	
Scope	Choose “VAR” in normal use. If global variable is used, choose “VAR_GLOBAL”. Refer to section 3.6.7 for further information.	
Name	Variable name is defined. (available characters are described in section 3.6.3.	
Type	Data type is defined. Refer to section 3.6.5 Data type.	
Object	In case of local variable, POU name is defined.	
Initialization	Initial value when program starting can be set here. If it’s blank, initialization value is 0.	
Address	No need to enter I/O address. EHV-CODESYS will assign to free address automatically.	
Comment	Any text comment can be input.	
Flags	CONSTANT	Enter a value in the Initialization field.
	RETAIN	The value is maintained by a battery after switch off of the PLC. If new application is downloaded, it will be initialized. (Refer to the section 3.13)
	PERSISTENT	The value is maintained by a battery after switch off of the PLC. If new application is downloaded, it will be maintained. (Refer to the section 3.13)

Bit access

Any bit data in integer type data can be accessed by adding suffix dot and number (decimal 0 to 63).

Example

```
wTest :=5; ← WORD type (16 bits)

wTest.0;
wTest.1;
wTest.2;
wTest.3; } ← BOOL type (1 bit)
```

Login display

```
wTest 16#0005 :=5;
wTest 16#0005.0 TRUE;
wTest 16#0005.1 FALSE;
wTest 16#0005.2 TRUE;
wTest 16#0005.3 FALSE;
```

3.6.2 Marker memory

Normally users do not have to take care about internal address of data memory however, if needed, the marker memory is useful. The address of marker memory is %M.

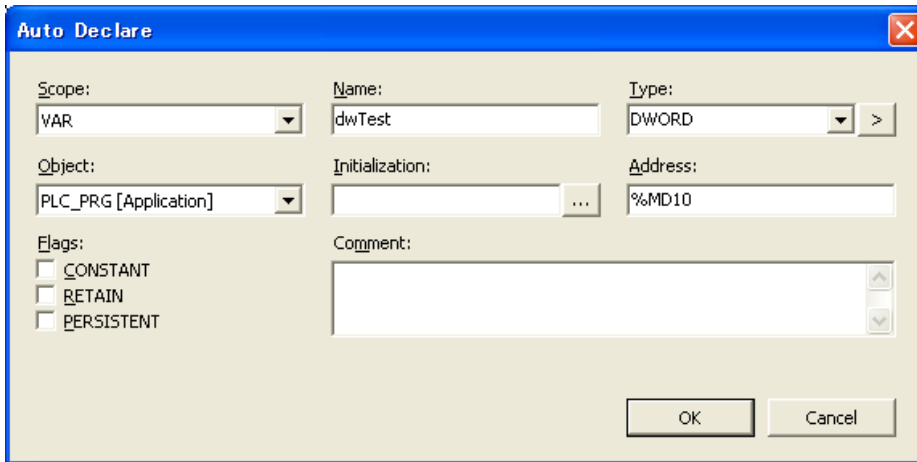

For example, DWORD data dwTest, WORD data wTest_H and wTest_L are declared in the address %MD10, %MW20 and %MW21. Then high word and low word can be accessed separately with using %M addresses. The relation between each data types are same as page 3-14. Just replace “Q” with “M”. The marker memory does not support RETAIN nor PERSISTENT flags.

Variable declaration

```

VAR
    dwTest AT %MD10: DWORD;
    wTest_H AT %MW20: WORD;
    wTest_L AT %MW21: WORD;
END_VAR

```

Login display

Expression	Type	Value
dwTest	DWORD	16#12345678
wTest_H	WORD	16#1234
wTest_L	WORD	16#5678

The max. size of marker memory is 16KB. Supported address range is shown below.

Data type	Address range
BOOL	%MX0.0 to %MX16383.7
BYTE	%MB0 to %MB16383
WORD	%MW0 to %MW8191
DWORD	%MD0 to %MD4095
LWORD	%ML0 to %ML2047

3.6.3 Available characters for variable names

Available characters for variable names are only alphabet a to z, A to Z and number 0 to 9 and _ (underscore). The first character must not be numeric characters. Several words like BOOL, WORD, IF, FOR etc. are reserved.

Supported characters

Types	Supported	Remarks
Numerical	0 to 9	Not allowed to begin with numeric characters.
Alphabetical	a to z, A to Z	
Symbol	_	Trailing underscores are not allowed.

Examples for variable names

Allowed or not	Examples	Descriptions
Allowed	Test_200	
	TEST	
	Test55	
	_Test	
Not allowed	2test	Starting with numeric character.
	test__200	Trailing underscores are not allowed
	test-5	Minus sign is not allowed.
	test#3	other signs than underscore are not allowed.
	test 3	Space is not allowed.
	IF	Reserved word.

3.6.4 Numeric literals

Numeric literals are specified as follows.

Types	Examples	Remarks
Integer	-12 0 123_456 +986 10#1234	Underscore is ignored
Real	-12.0 0.0 0.4560 3.14159_26	Underscore is ignored
Real with exponents	-1.34E-12 1.0E+6 1.23E6	
Base 2	2#1111_1111 2#1110_0000	Underscore is ignored
Base 8	8#377 8#340	
Base 16	16#FF 16#ff 16#1234_ABCD	Underscore is ignored
Boolean zero and one	0 1 FALSE TRUE	FALSE=0, TRUE=1
Time	T#100ms, T#5.5s	Timer (TON, etc.)
Date	DT#2012-12-31-12:34:56	RTC (Realtime clock)

3.6.5 Data types

EHV-CODESYS supports below data types.

No.	Data types	Name	Size	Range
1	BOOL	Boolean	1	0 or 1
2	SINT	Short integer	8	-128 to 127
3	USINT	Unsigned short integer	8	0 to 255
4	BYTE	Bit string of length 8	8	0 to 255 (16#00 to 16#FF)
5	INT	Integer	16	-32,768 to 32,767
6	UINT	Unsigned integer	16	0 to 65,535
7	WORD	Bit string of length 16	16	0 to 65,535 (16#00 to 16#FFFF)
8	DINT	Double integer	32	-2,147,483,648 to 2,147,483,647
9	UDINT	Unsigned double integer	32	0 to 4,294,967,295
10	DWORD	Bit string of length 32	32	0 to 4,294,967,295 (16#00 to 16#FFFFFFFF)
11	REAL	Real numbers	32	$\pm 1.175494351 \text{ E-}38$ to $3.402823466 \text{ E+}38$
12	TIME	Duration	32	0 to 4,294,967,295 ms Unit : "d": days, "h": hours, "m": minutes, "s": seconds, "ms": milliseconds Ex. T#100S12ms, t#0.1s
13	LREAL	Long reals	64	$\pm 1.7976931348623 \dots \text{ E+}308$ to $2.2250738585072 \dots \text{ E-}308$
14	STRING	Variable-length single-byte character string	8× n	1 to 255 char.
15	LINT	Long integer	64	$-2^{63} \sim 2^{63}-1$
16	ULINT	Unsigned long integer	64	0 to $2^{64}-1$
17	LWORD	Bit string of length 64	64	0 to $2^{64}-1$
18	DATE	Date	32	year-month-day Ex. DATE#1996-05-06 d#1972-03-29
19	DATE_AND_TIME	Date and time of Day	32	year-month-day-hour:minute:second Ex. DATE_AND_TIME#1996-05-06-15:36:30 dt#1972-03-29-00:00:00
20	TIME_OF_DAY	Time of day	32	hour:minute:second Ex. TIME_OF_DAY#15:36:30.123 tod#00:00:00
21	LTIME	Long duration	64	Unit : "us": microseconds, "ns": nanoseconds Ex. LTIME#1000d15h23m12s34ms2us44ns
22	WSTRING	Variable-length double-byte character string	16× n	
23	ARRAY	Array	—	Ex. in variable declaration test: ARRAY[0..100] OF WORD; in user program test[5]:=20;

Note

If ARRAY type variables are used, several additional variables are used implicitly in the data memory.

3.6.6 Local variable

If new variable name is used in POU, Auto Declare window appears as below. If the field “Address” is remained as empty, this variable will be assigned in a certain memory area of CPU.

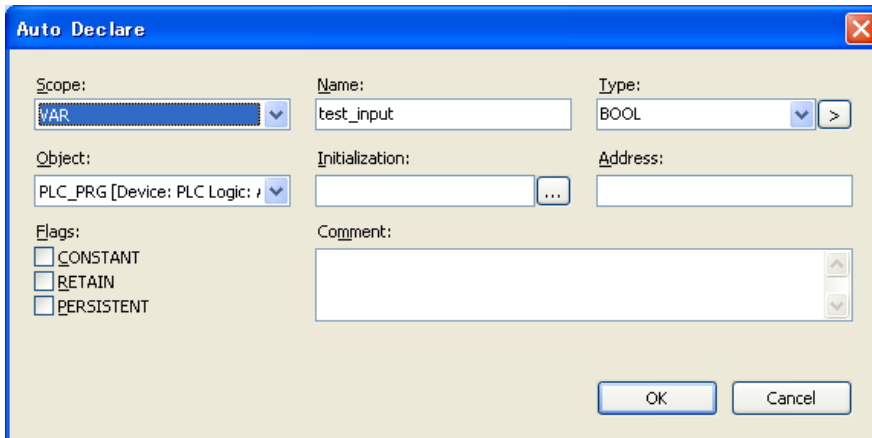

Click [OK] button, this variable is registered in declaration part of POU as below.

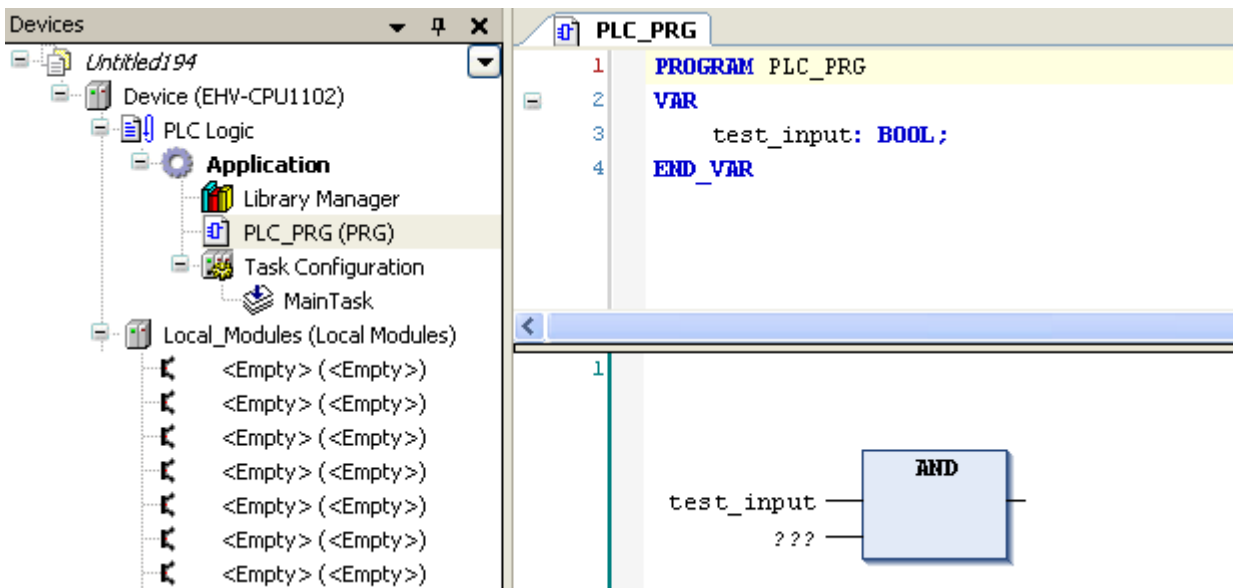

This variable is valid only in the POU. Even if same variable name is used in another POU, Auto Declare window will appear and it will be assigned in another memory location and handled as different variable.

3.6.7 Global variable

If variables need to be commonly used in all POU, “Global Variable List” must be created by right click on Application as below.

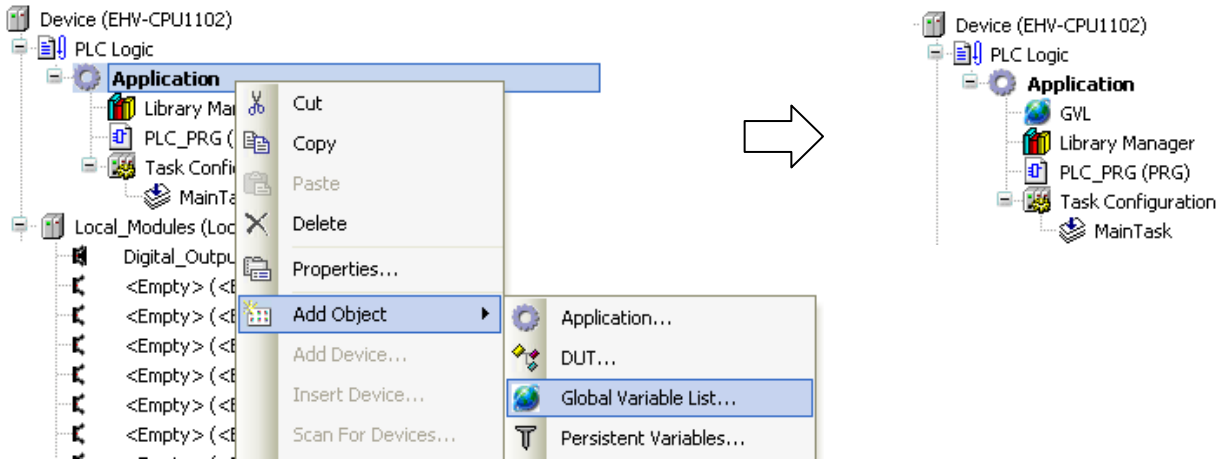

If new variable name is used in POU, Auto Declare window appears as shown in local variables. Choose “VAR_GLOBAL” at “Scope” as below.

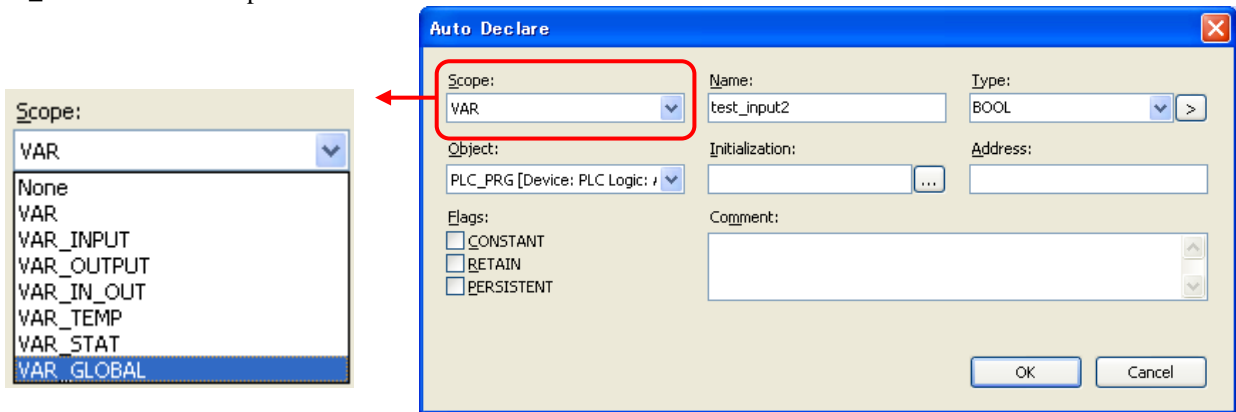

New variable name “test_input2” is registered in GVL as below instead of POU.

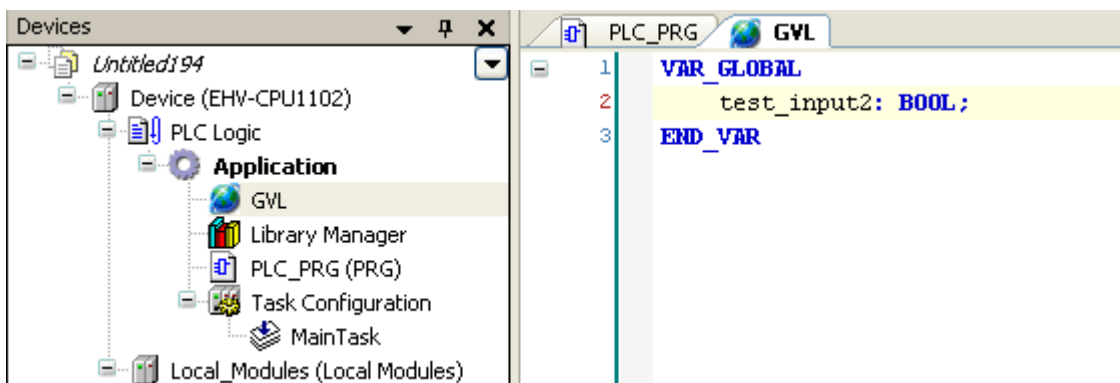

3.7 Configuration

Open device window and set CPU's parameters in Configuration tab.

Parameter	Description	
IP Address	When requesting to change the Ethernet port related parameters, be sure to set “Yes” in “Change IP information”, otherwise parameters are not downloaded. Do not forget to set back to “No” after downloading.	
Subnet Mask		
Default Gateway		
Ethernet port Link speed / Duplex mode		
Change IP information	No	IP information is not downloaded when application downloading.
	Yes	IP information is downloaded together with application.
Serial port mode	Gateway	Communication with EHV-CODESYS/HMI (CPU V3.4 only)
	IEC programming	Modbus-RTU or SysCom communication
Serial port type	RS-232C	The serial port is set as RS-232C interface.
	RS-422/485	The serial port is set as RS-422/485 interface.
Serial port term. resistor (RS-422/485)	No	No terminal resistor
	Yes	120Ω resistor is across [7] RX+ and [6] RX- of serial port.
Reset all outputs in STOP	Yes	all outputs are reset by hardware signal on the backplane when switching to stop mode. (Refer to page 3-16)
	No	all outputs are controlled by IEC program (software)
Stop switch definition	Reset warm	When Run/stop switch is changed from run to stop, “Reset warm” operation is performed.
	Stop	When Run/stop switch is changed from run to stop, “Stop” operation is performed.
External PHY Clock	This setting is valid only for hardware revision 01 or newer. Do NOT set “Yes” in the hardware revision 00, otherwise Ethernet port will not work.	

Default settings

Device x									
Communication Settings		Applications	Files	Log	PLC settings	PLC shell	Users and Groups	Access Rights	Configuration
Parameter	Type	Value	Default Value	Unit					
IP Address	STRING	'192.168.0.1'	'192.168.0.1'						
Subnet Mask	STRING	'255.255.255.0'	'255.255.255.0'						
Default Gateway	STRING	'0.0.0.0'	'0.0.0.0'						
Ethernet port Link speed / Duplex mode	Enumeration of BYTE	Auto Negotiation	Auto Negotiation						
Change IP information	Enumeration of BYTE	No	No						
Serial port mode	Enumeration of BYTE	IEC programming	IEC programming						
Serial port type	Enumeration of BYTE	RS-232C	RS-232C						
Serial port term. resistor (RS-422/485)	Enumeration of BYTE	No	No						
Reset all outputs in STOP	Enumeration of BYTE	Yes	Yes						
Stop switch definition	Enumeration of BYTE	Reset warm	Reset warm						
External PHY Clock	Enumeration of BYTE	Yes	Yes						

Note

- The parameter “Ethernet port Link speed / Duplex mode” requires power cycling to update parameter data. All the other parameters are updated when program is downloaded.
- Serial port mode is “IEC programming” only in CPU V3.5.
- Default values of Ethernet port Link speed and External PHY Clock have been changed since CPU V3.5.

3.8 Communication settings

How to configure

Double click on “Device (EHV-CPUxxxx)” or right click and choose “Edit Object”.

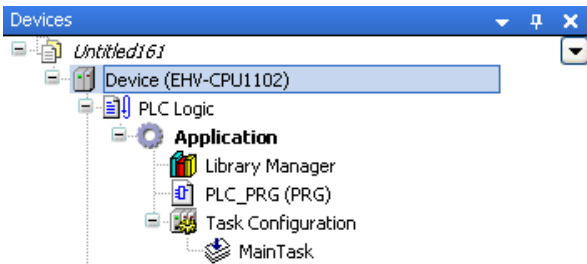

“Device” window will appear as below. Choose “Communication Settings” tab and click “Scan network”.

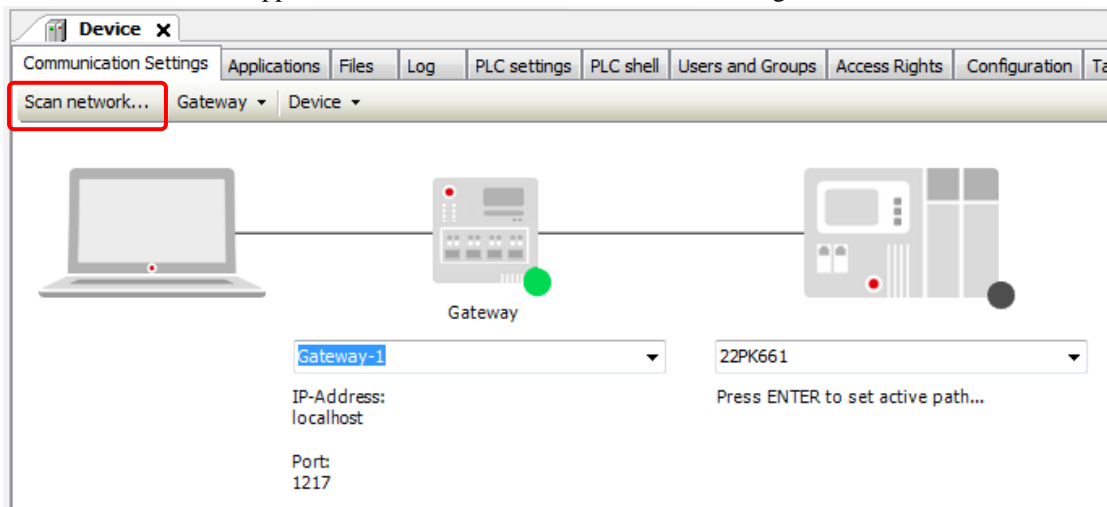

If CPU is found, it is displayed as below. Click “OK” to close the window.

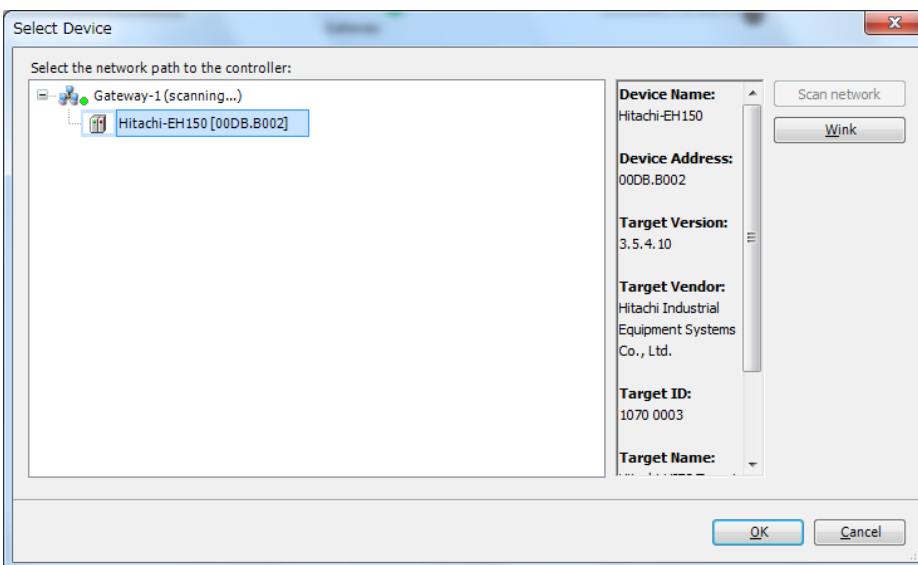

Target CPU is configured. The CPU types are identified by Target ID.

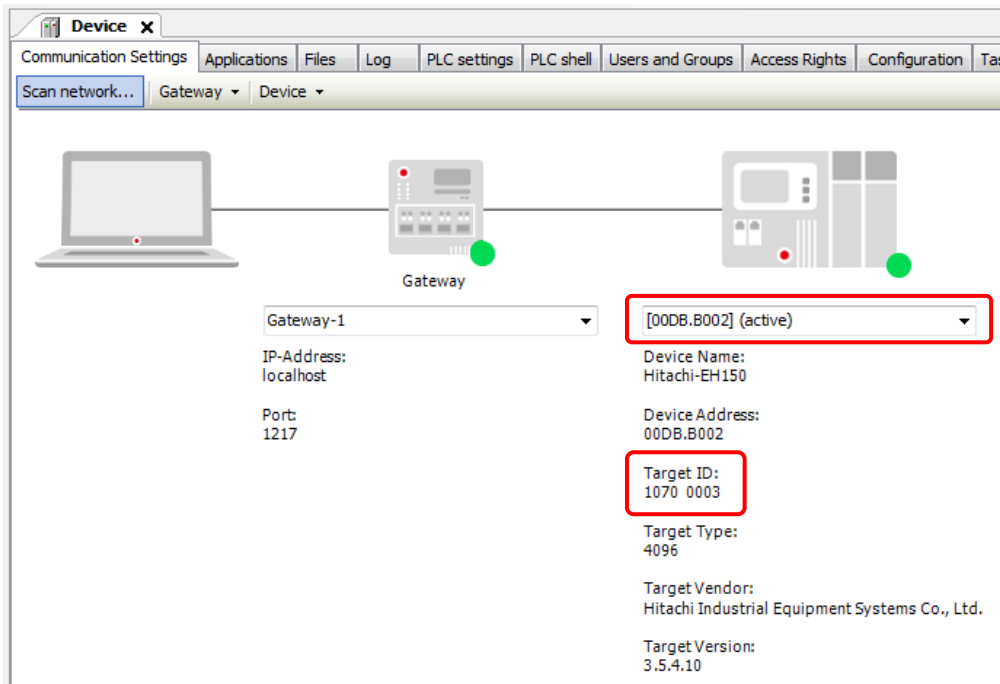

CPU name	Target ID
EHV-CPU1102	16#1070 0001
EHV-CPU1025	16#1070 0003

TCP/IP communication (CPU V3.5)

Default protocol between CODESYS and CPU is UDP/IP. If TCP/IP communication is required, enter IP address in the Device Name field directly. TCP/IP is supported by CPU ROM VER. 3.5.x.x.

Note

- Even if Ethernet and USB cable are connected, only the first detected communication line is displayed.

3.9 Programming

Ladder programming

Basic ladder programming is shown below as a first step. Please refer to online-help of EHV-CODESYS for further information about programming.

Several ways are available to add contact or coil to POU as below.

Contact

- Drag from ToolBox to [Start here].
- Menu [FBD/LD/IL]-[Insert Contact]
- Right mouse click [Insert Contact]
- Shortcut key [Ctrl + K]

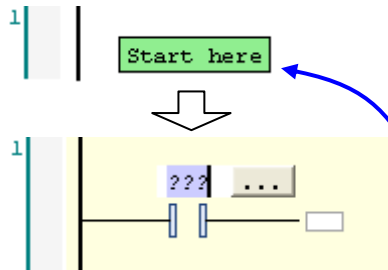

Coil

- Drag from ToolBox to [Add output or jump here].
- Menu [FBD/LD/IL]-[Insert Coil]
- Right mouse click [Insert Coil]
- Shortcut key [Ctrl + A]

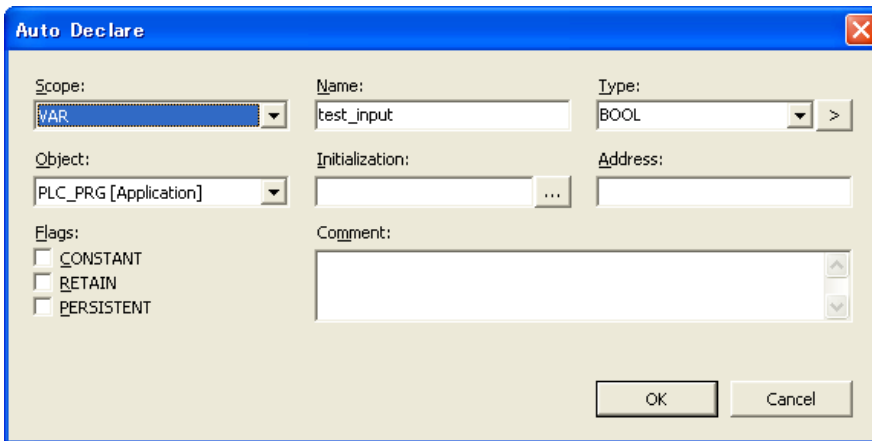
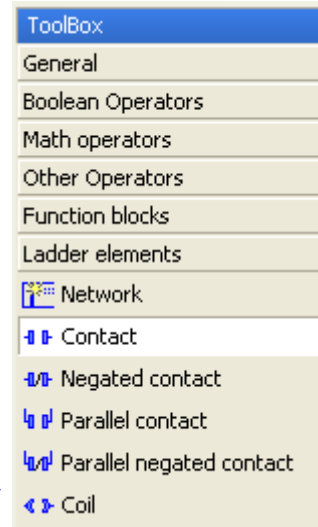
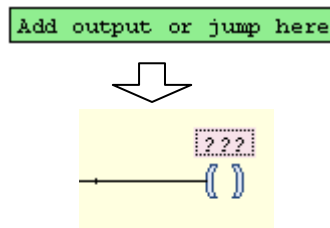

If new variable name is used, Auto Declare window appears automatically. Edit each input field and check-boxes if necessary, and Click [OK]. The variable is declared in declaration window as below.

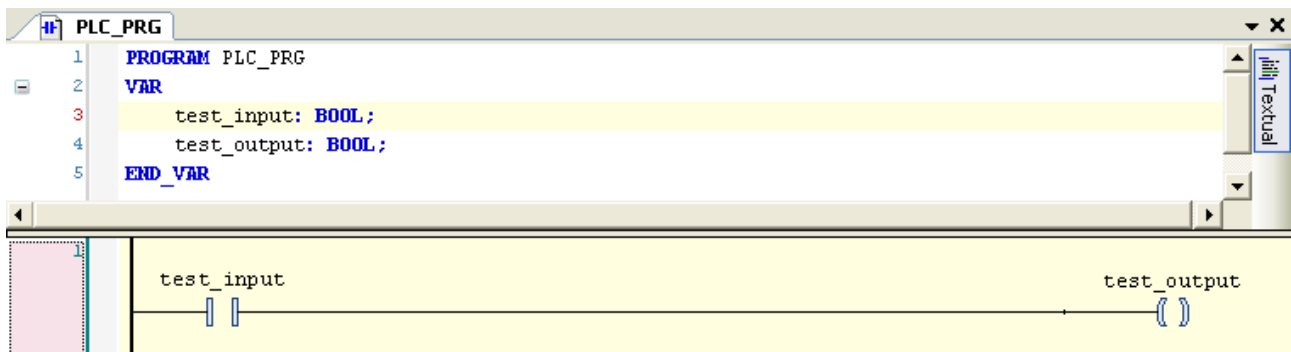

Parallel contact across several contacts

Click several contacts with shift key and choose [Insert Contact Parallel] in right-mouse click menu or press [Ctrl + R] key.

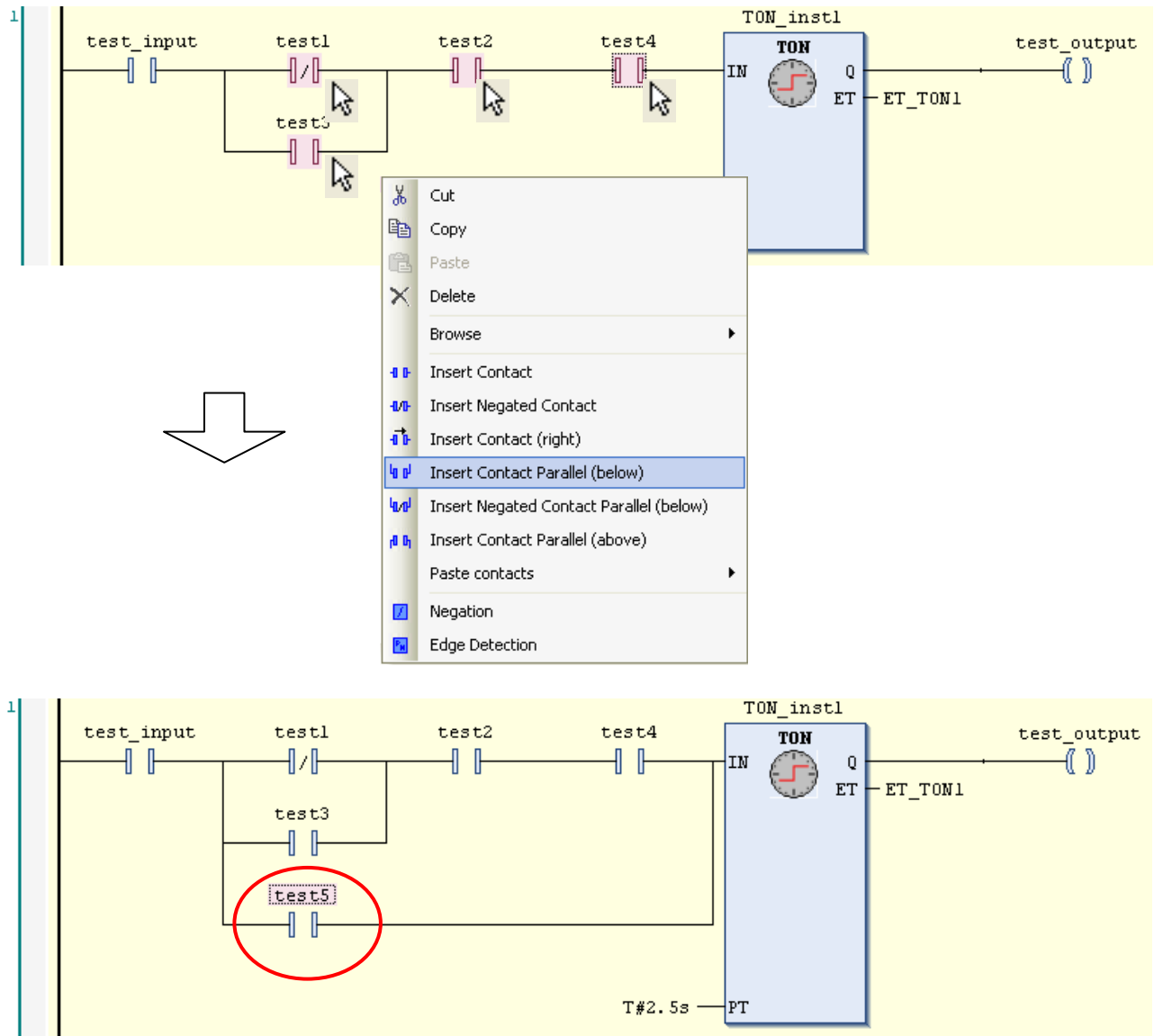

3.10 Login

Login

After programming, click  or choose [Build] in Build menu. If compiling fails, error information is shown at “Description” field as follows. Double click the message to jump to the part to be corrected.

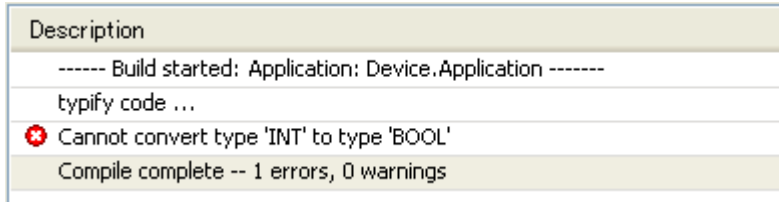

Note

If unknown message appears, it is recommended to [Clean all] in Build menu. All compile information is deleted by this operation.

When all errors are removed as below, click  or choose [Login] in Online menu to download the program to CPU.



If no application is in the CPU, this message appears. Click [Yes] to download.

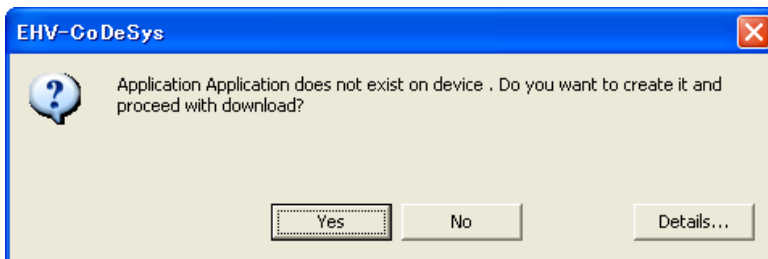

If unknown version of application is in the CPU, this message appears. Click [Yes] to download.

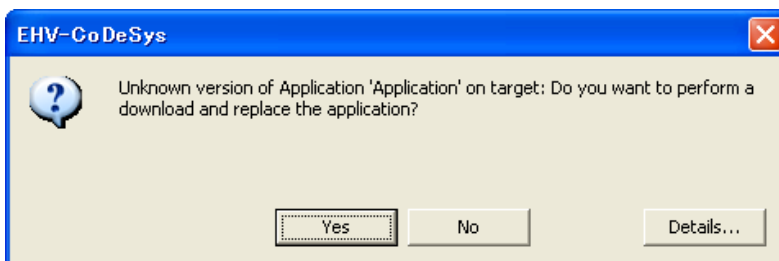

When logging in successfully, green circle icon is displayed at [Device]. If mounted I/O modules are matched with configured ones, green icon is displayed at each I/O module also.

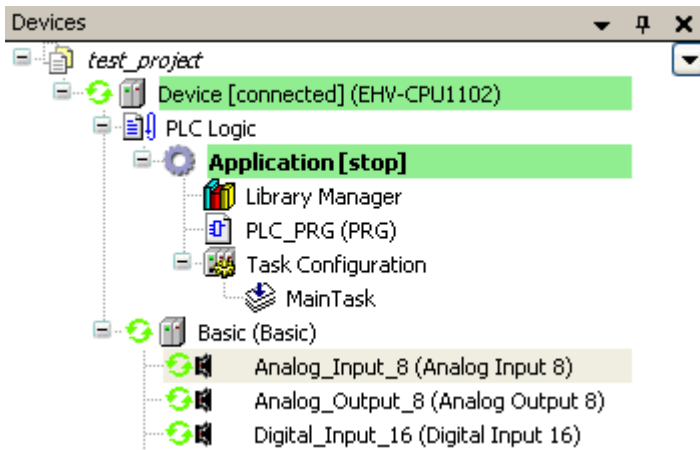

If any mounted I/O module is mismatched, red triangle icon is displayed at mismatched module as below.

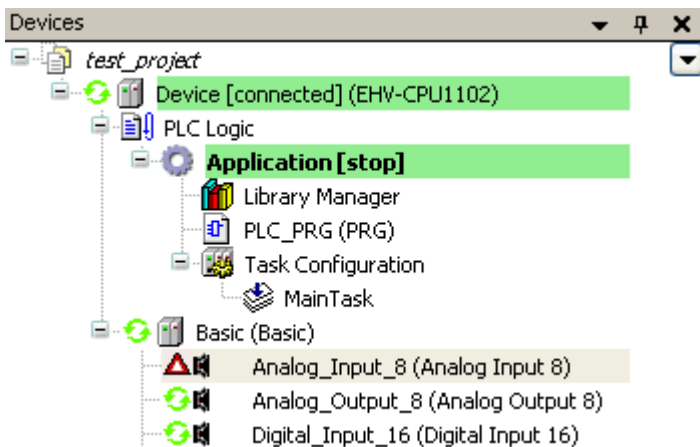

Online monitoring

After login, actual status of variables are shown as below.

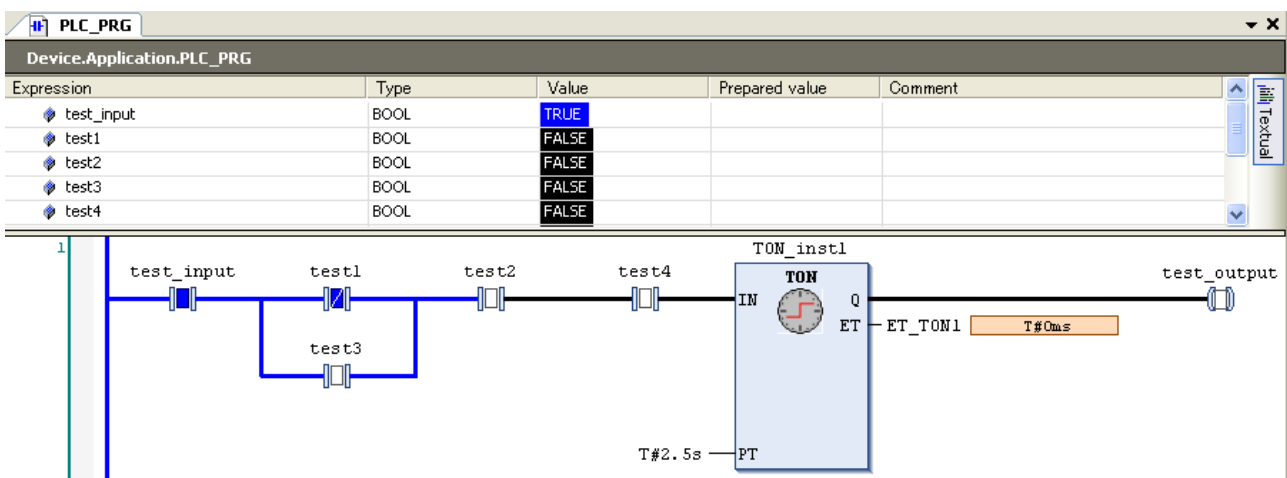

Write values

Prepare values for the variables by clicking at [Prepared value] or double clicking at ladder symbols. Choose the menu [Debug]-[Write values] or press [Ctrl + F7]. The prepared values will be transferred to PLC.

Expression	Type	Value	Prepared value	Comment
test_input	BOOL	TRUE		
test1	BOOL	FALSE		
test2	BOOL	FALSE	TRUE	
test3	BOOL	FALSE		
test4	BOOL	FALSE	TRUE	

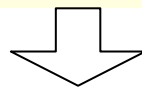

Write values Ctrl+F7

Expression	Type	Value	Prepared value	Comment
test_input	BOOL	TRUE		
test1	BOOL	FALSE		
test2	BOOL	TRUE		
test3	BOOL	FALSE		
test4	BOOL	TRUE		

Online change

To change your program in running CPU (online change), you have to logout at first. After program changing, choose [Login] again. You will have 3 options as below.

- Login with online change: Only incremental program is downloaded without CPU stop.
- Login with download: Whole the program is downloaded. CPU is forced to stop.
- Login without any change: New program is not downloaded.

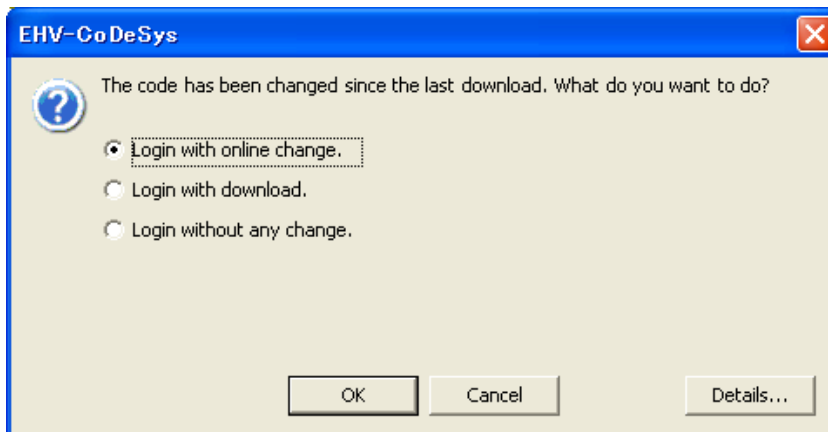

3.11 Boot application

The basic overview of downloading is shown as below picture. Be noted that an application (compiled user program) is downloaded to volatile RAM memory of the CPU, which means the application is lost when power is removed. If your application needs to be saved in non-volatile FLASH memory, choose [Create boot application] in Online menu while Login. When CPU is power up in the next time, the application is copied from FLASH to RAM and executed automatically if RUN/STOP switch is in RUN position.

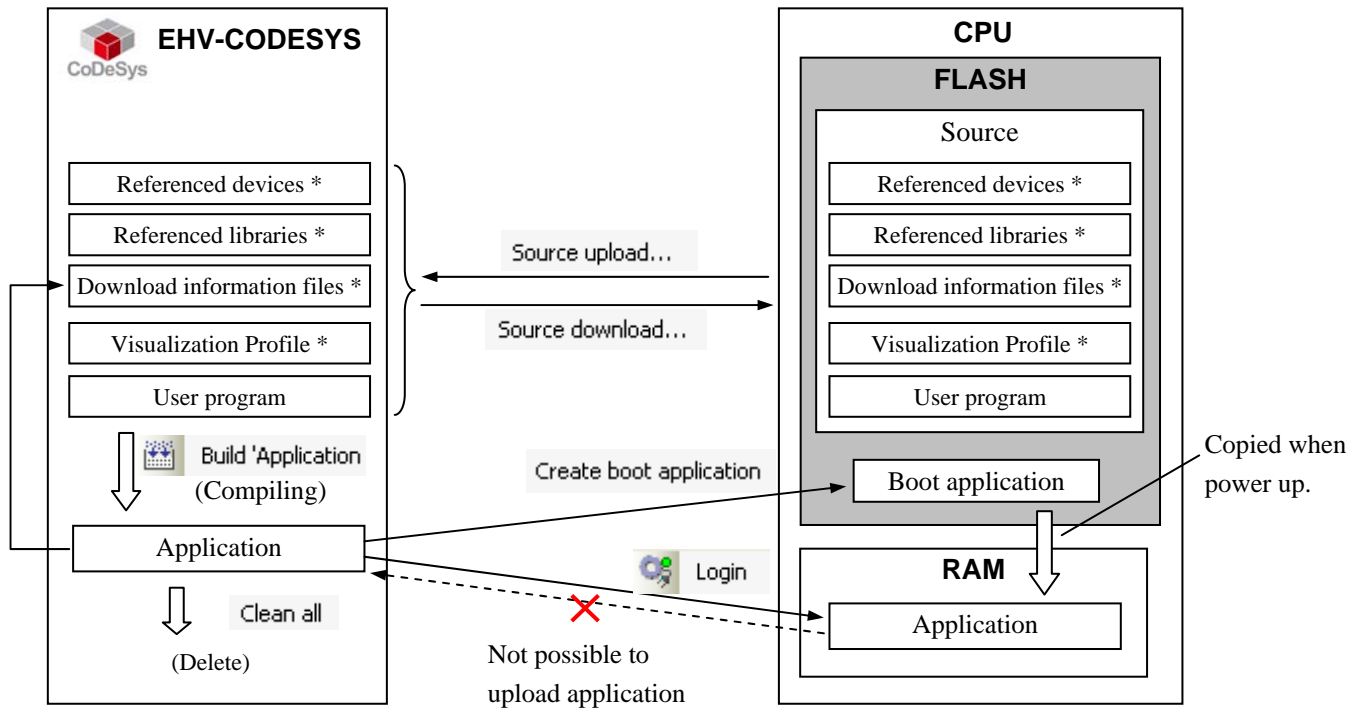

*: Optional

Timing to download boot application can be configured in [Properties] of [Application] (Right click on “Application” of the project tree). The default setting is shown below.

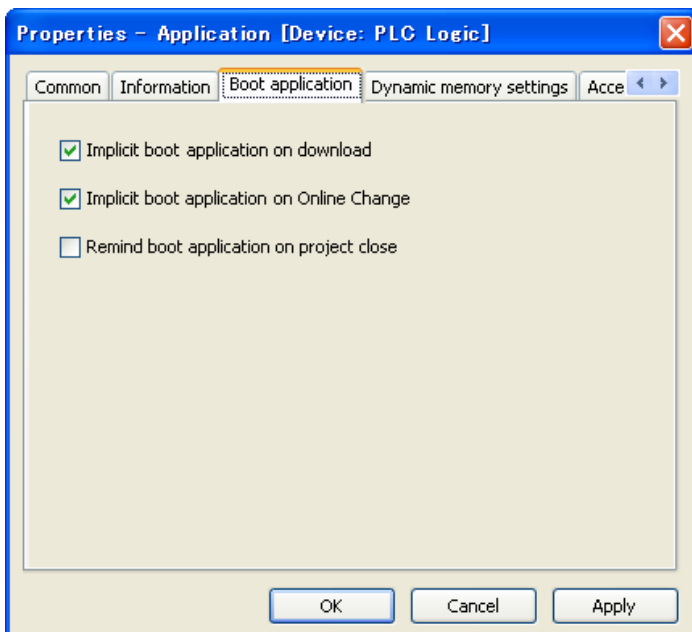

3.12 Source Download / Upload

Besides boot application, source file can be saved in the CPU module, which enables you to upload original program file from PLC even if you don't have it in your PC. Some extra files can be added to source file as below. Choose according to your necessity.

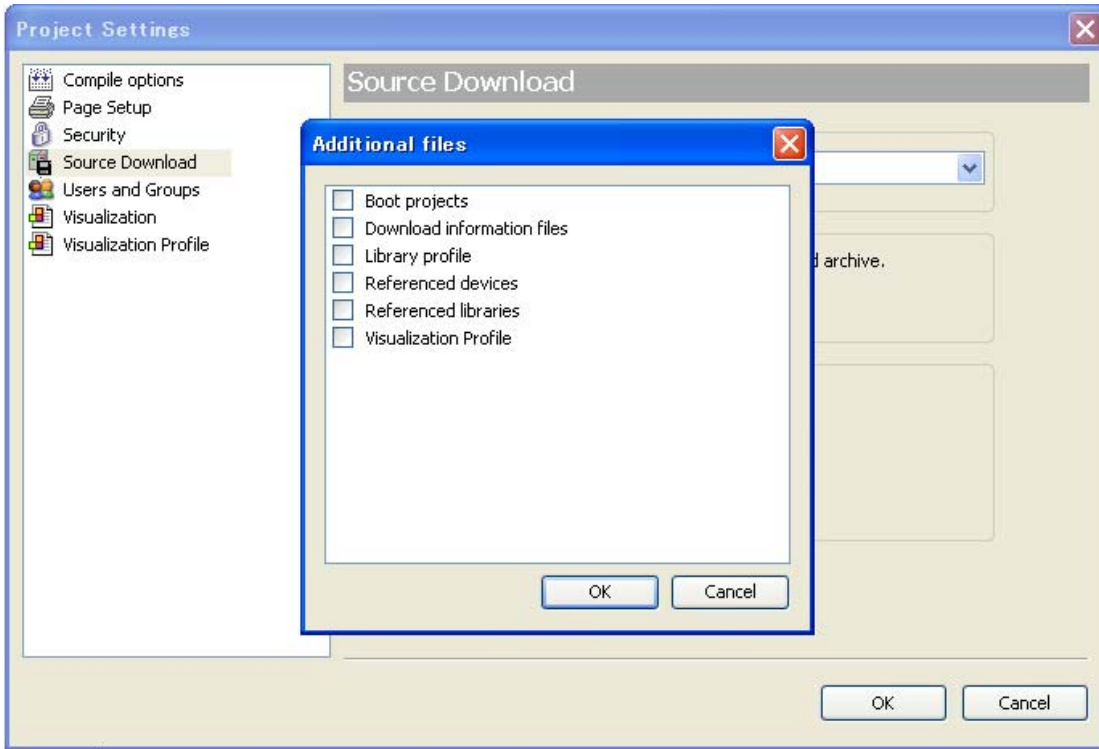

Download information files

“Download information files” in [additional files setting] is not necessary normally, but it is needed if you want to login without CPU stop from the PC which does not have original program file shown below as case (b) and (c).

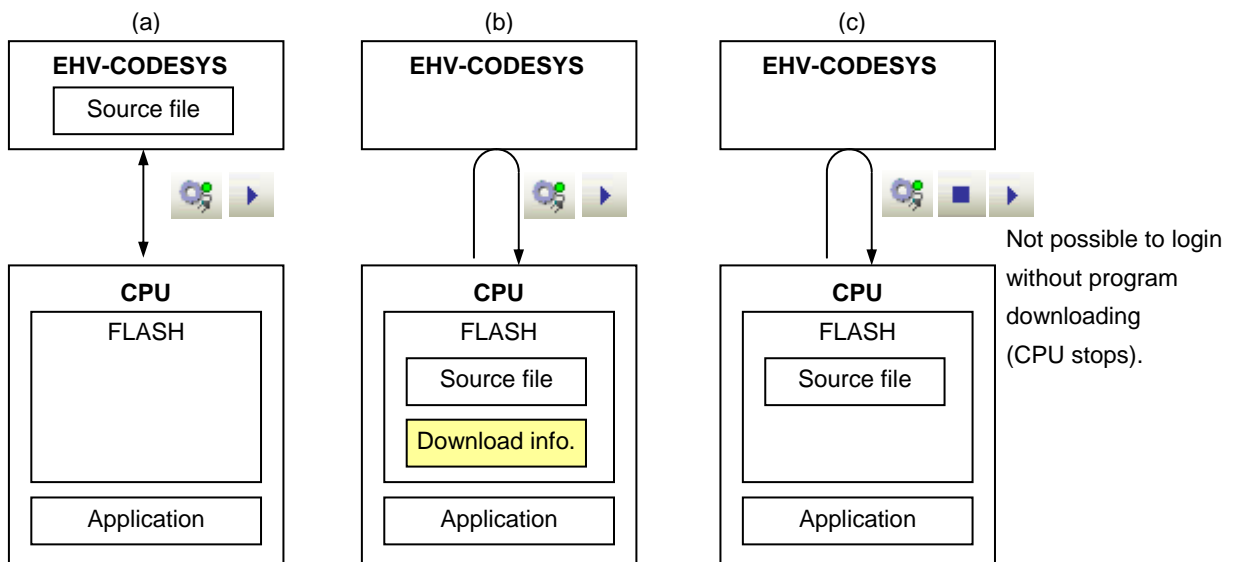

- (a) Online change from PC with source file to CPU without source file. → Login
- (b) Online change from PC without source file to CPU with source file and DL info. → Source upload and Login
- (c) Online change from PC without source file to CPU with source file. → Source upload and Login, then program download is required because EHV-CODESYS is not able to verify program identity. It is possible to login after downloading, but CPU must stop at that time.



3.13 Run / Stop / Reset

Run/Stop

CPU can be started with EHV-CODESYS or Run/Stop switch on the CPU module, but remote controlling with EHV-CODESYS is not allowed when the Run/stop switch is in Stop position as shown below.

Switch position	STOP	RUN
User operations		
Stop with EHV-CODESYS 	Stop (no effect)	Stop
Run with EHV-CODESYS 	Stop (no effect)	Run
Reboot PLC (Cycle power)	Stop	Run *

* CPU starts running independent from the last status before power failure.

Reset











When CPU detects a serious error called “exception”, such as watchdog error, program execution stops. If EHV-CODESYS is connected, “Exception” indication blinks until this status is cleared. This exception status is cleared only by “Reset” operation. EHV-CODESYS has 3 different types of “Reset” operation: Reset warm, Reset cold and Reset origin. All of them can initialize exception status, but behaviours of CPU are different as shown below. Be noted that “Reset origin” initializes not only an exception but also your application and boot application in CPU module.

Operation	VAR	VAR RETAIN	VAR PERSISTENT	Application (in volatile memory)	Boot application (in non-volatile)
STOP	X	X	X	X	X
Reset warm	-	X	X	X	X
Reset cold	-	-	X	X	X
Reset origin	-	-	-	-	-
Download	-	-	X	(overwritten)	X
Online Change	X	X	X	(modified)	X
Reboot PLC	-	X	X	-	X

X = maintained, - = initialized

Stop switch definition

Definition of stop position of run/stop switch can be configured as “Stop” or “Reset warm” in CPU configuration. Default setting is “Reset warm” since it is almost same behaviour of original “Stop” for existing Hitachi PLC.

Parameter	Type	Value	Default Value
 IP Address	STRING	'192.168.0.1'	'192.168.0.1'
 Subnet Mask	STRING	'255.255.255.0'	'255.255.255.0'
 Default Gateway	STRING	'0.0.0.0'	'0.0.0.0'
 Ethernet port Link speed / Duplex mode	Enumeration of BYTE	AutoNegotiation	AutoNegotiation
 Change IP information	Enumeration of BYTE	No	No
 Serial port mode	Enumeration of BYTE	IEC programming	IEC programming
 Serial port type	Enumeration of BYTE	RS-232C	RS-232C
 Serial port term. resistor (RS-422/485)	Enumeration of BYTE	No	No
 Reset all outputs in STOP	Enumeration of BYTE	Yes	Yes
 Stop switch definition	Enumeration of BYTE	Reset warm	Reset warm
 External PHY Clock	Enumeration of BYTE	Yes	Yes

3.14 Global network variables

Any variables can be listed in global network variable list, which are sent to all other CPUs in the network with broadcast address of UDP/IP. Global network variable function is available only in professional setting. Refer to section 3.2 Start up how to change the environment setting.

How to configure?

Procedure of configuration is shown below with a simple project: one CPU to send and the other CPU to receive. Right click on the project and choose “Add Device” to add the 2nd CPU.

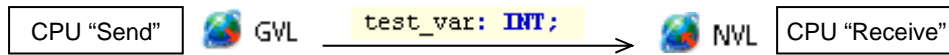

[CPU “Send”]

Right click on “Application” of send-CPU and choose “Network Variable List (Sender)”.

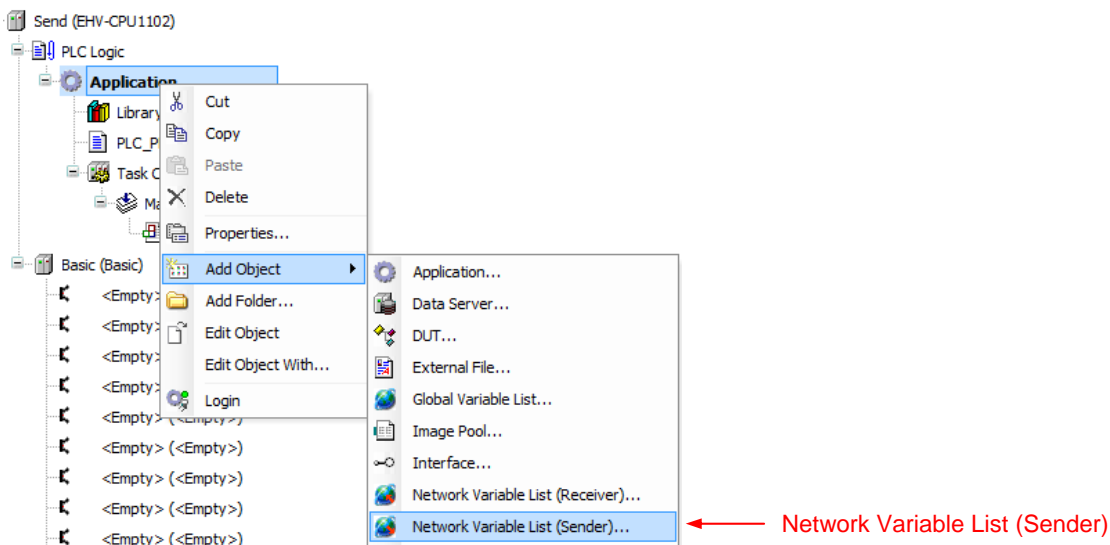

Click “Network properties” tab and configure as below.

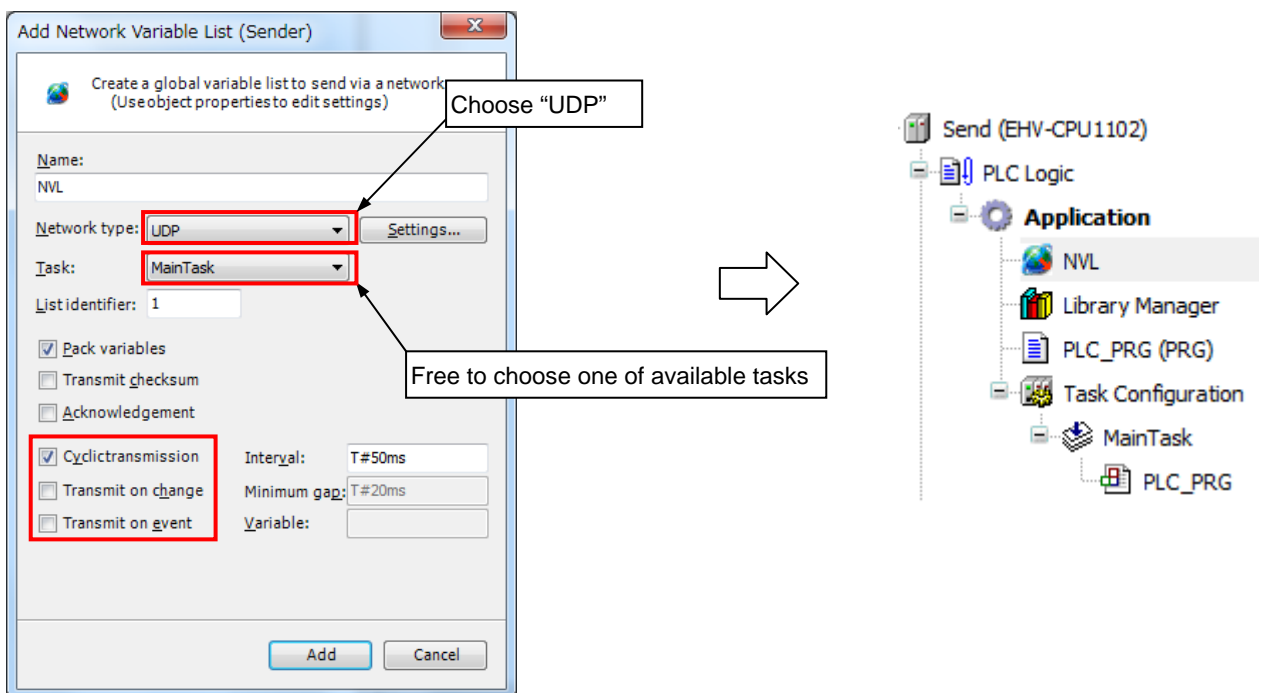

Network type: Choose “UDP”.

Task: Choose any one task. The variables are sent at the end of a task cycle.

List identifier: If more than 2 global variable list is configured, set a number in ascending order.

Cyclic transmission: Since variables are sent every task cycle, set interval time as same or bigger than cycle time of configured task. If smaller time than task cycle is set, actual sending cycle is limited by task cycle.

Transmit on change: Variables are sent only if their values have changed; the Minimum gap can define a minimum time lapse between transfers.

Transmit on event: Variables are sent while specified variable is TRUE. Be noted that it is not edge detection but level detection.

Refer to online help of EHV-CODESYS for further information.

In this sample, one global variable “test_var” is defined and one-line program is written in POU as below.

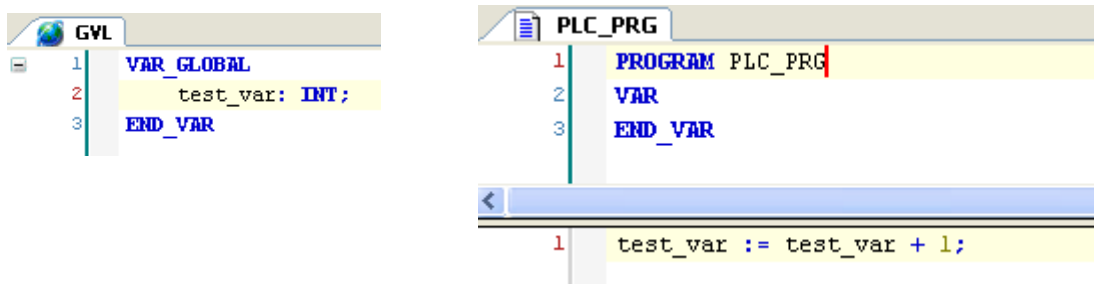

[CPU “Receive”]

The next step is configuration for receiving CPU. Right click on “Application” of Receive-CPU and choose “Global Network Variable List...” Be sure to check if Sender is properly set as configured list above.

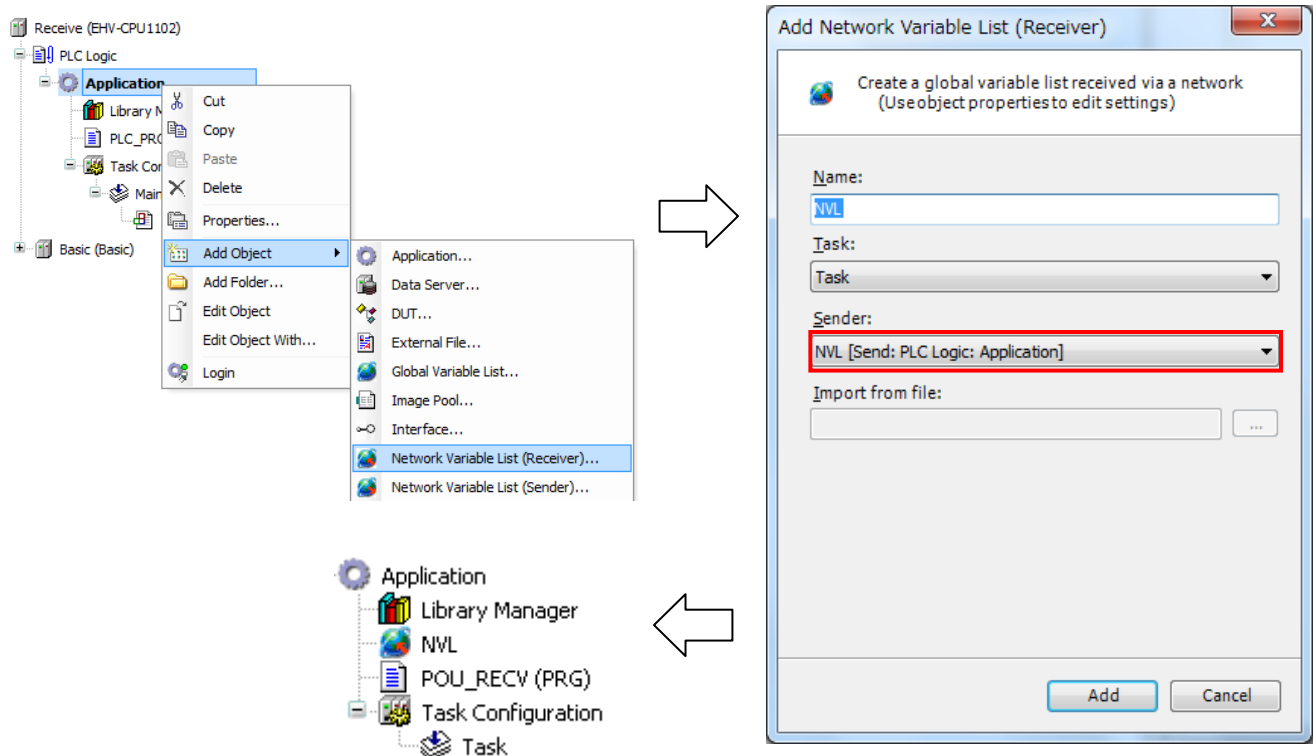

Configuration is completed for both send and receive-CPU.

Login

Set the communication path for Send-CPU and login (download application).

After logout, right click on “Application” of Receive-CPU and choose “Set Active Application”.

Set the communication path for Receive-CPU and login (download application).

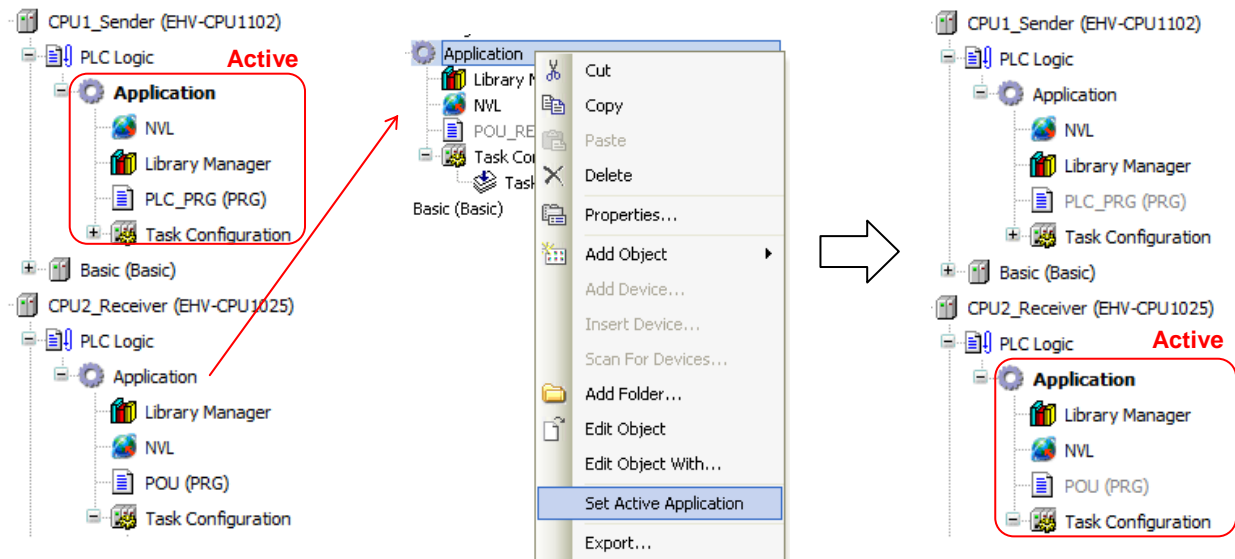

You can see the variable “test_var” is counting up in the global network variable list in the Receive-CPU.

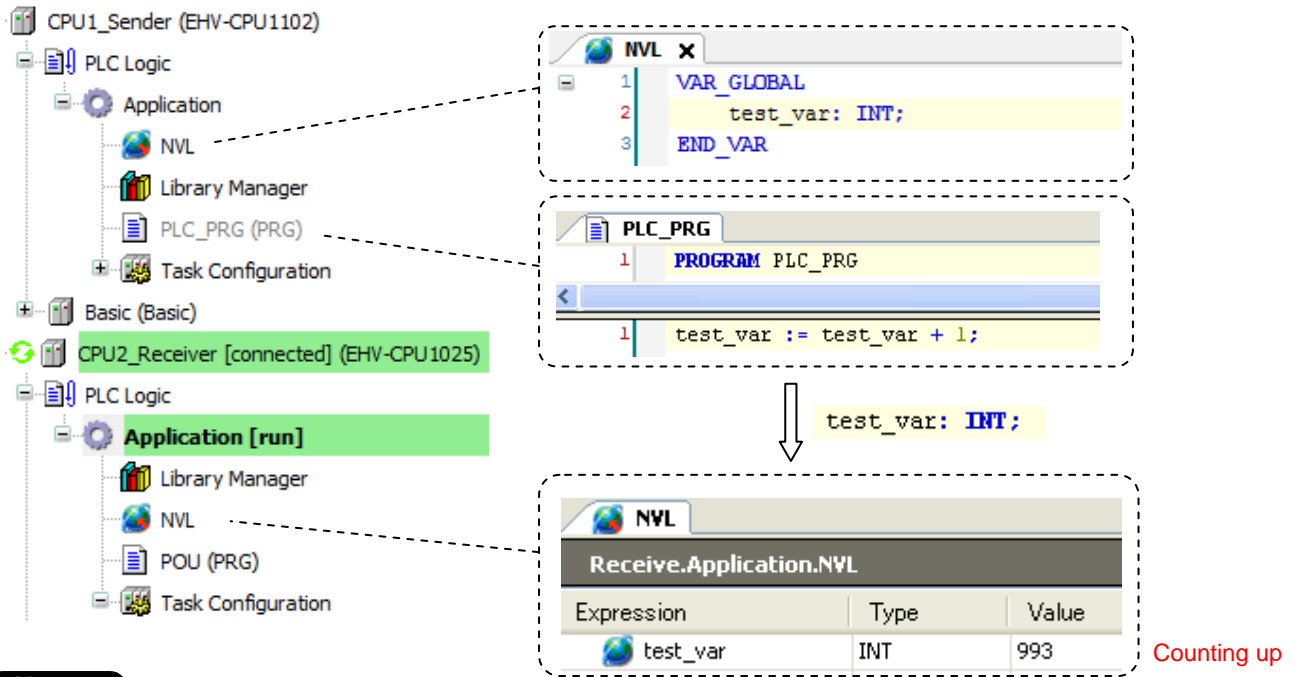

Note

- If any parameters of global variable list is changed, be sure to execute “Clean” or “Clean All” before login.
- If communication traffic is very high (e.g. many data over OPC), assign GVL to another task than MainTask.
- If more than 2 global variable lists are configured, be sure to set another “List identifier” in ascending order.

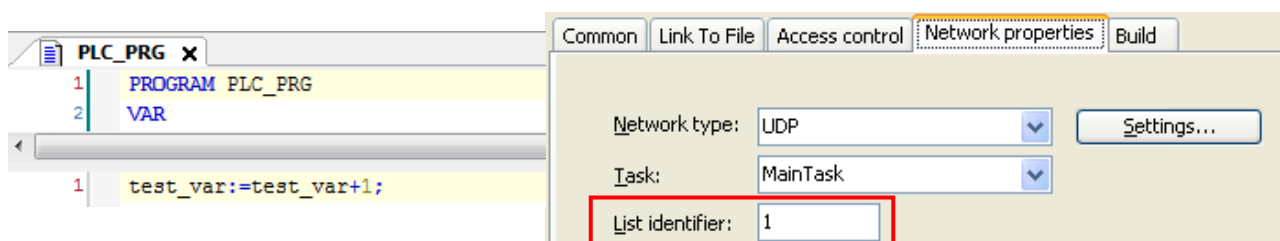

3.15 Modbus-TCP/RTU

3.15.1 Introduction

Supported function codes are shown in the below table.

16#	10#	Function code	CPU		EH-SIO
			Modbus-TCP Master Modbus-RTU Master	Modbus-TCP Slave	Modbus-RTU Master
0x01	01	Read Coils	X	-	X
0x02	02	Read Discrete Inputs	X	-	X
0x03	03	Read Holding Registers	X	X	X
0x04	04	Read Input Registers	X	X	X
0x05	05	Write Single Coil	X	-	X
0x06	06	Write Single Register	X	X	X
0x0F	15	Write Multiple Coils	X	-	X
0x10	16	Write Multiple Registers	X	X	X
0x17	23	Read/Write Multiple Registers	X	X	X

X = Supported, - = Not supported

Modbus command processing is executed in bus cycle task, which is configured in PLC settings of Device as below. You can specify any existing IEC tasks. If the bus cycle task is <unspecified>, task with the shortest cycle time is taken.

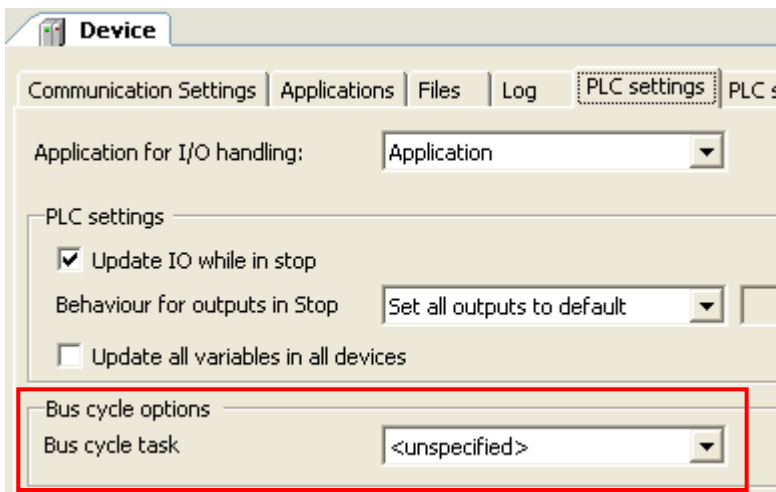

Note

EHV-CPU ROM VER.3.4.x.x requires Modbus devices V3.4. Refer to section 3.22 for further information.

3.15.2 Modbus-TCP master (client)

Right click on “Device” and choose “Add Device...”.

“Add Device” window appears.

Click “Ethernet” and [Add Device] button.

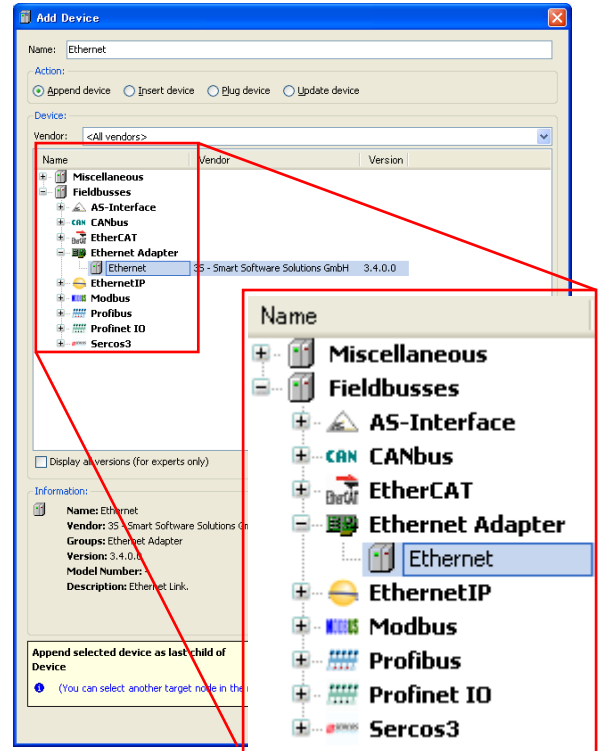
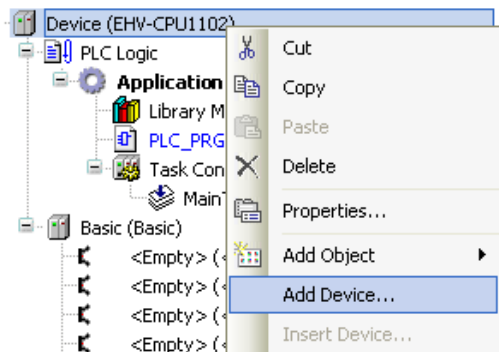

With “Add device” window opened, click “Ethernet” in the device tree. Then available devices will be shown in the “Add Device” window. Click “Modbus TCP master” and [Add Device] button

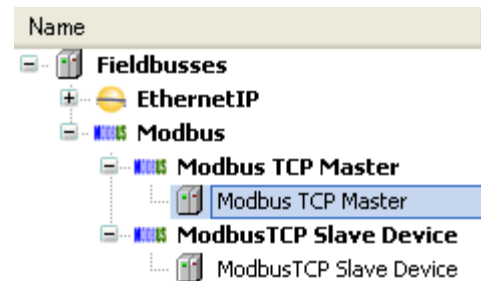
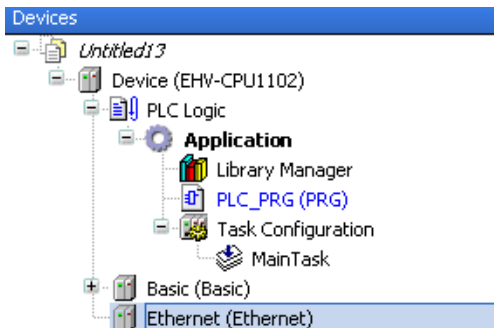

With “Add device” window opened, click “Modbus_TCP_master” in the device tree. Then “Modbus TCP Slave” is shown in the “Add Device” window. Click “Modbus TCP slave” and [Add Device] button according to your Modbus system configuration. e.g. if 3 slaves are to be controlled, add 3 times of slave devices.

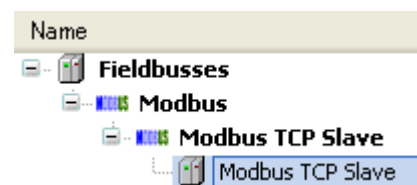
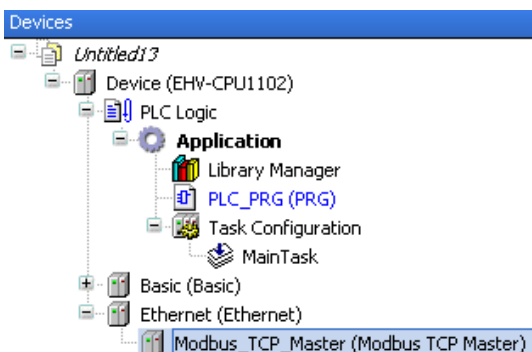

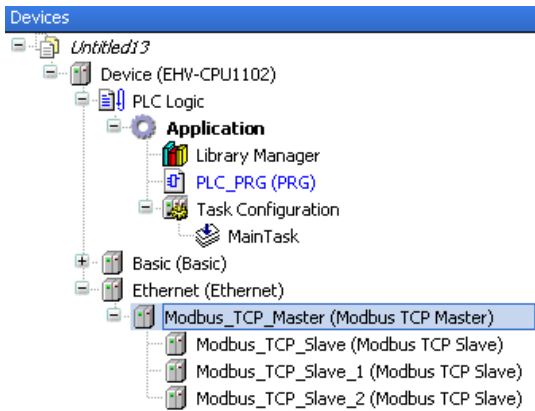

Be sure to configure all slave modules to be controlled.

Function codes to be sent are configured in each slave. Double click a slave unit to open configuration window.

Set IP address, response timeout and port number as below. Unit-ID is used when a Modbus-gateway (Ethernet to serial) device is used.

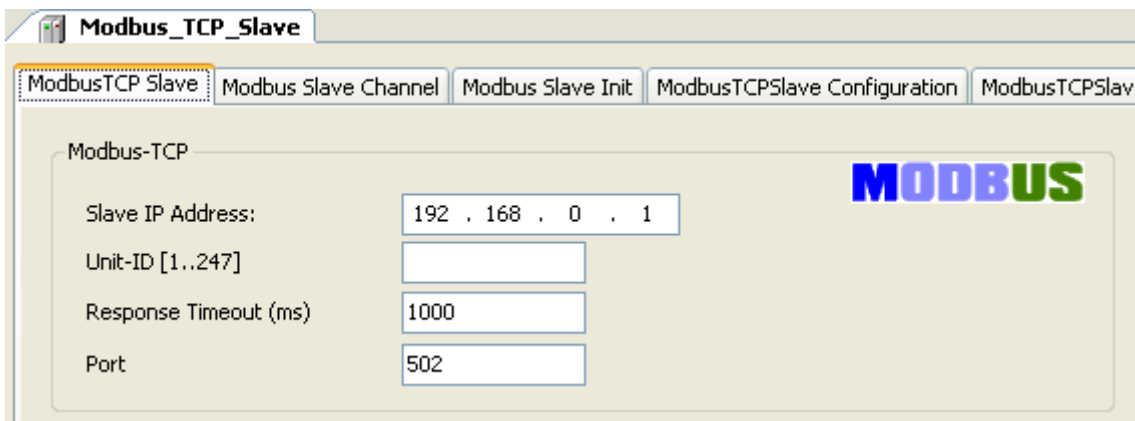

Open “Modbus Slave Channel” tab and click “Add Channel...” to add function codes.

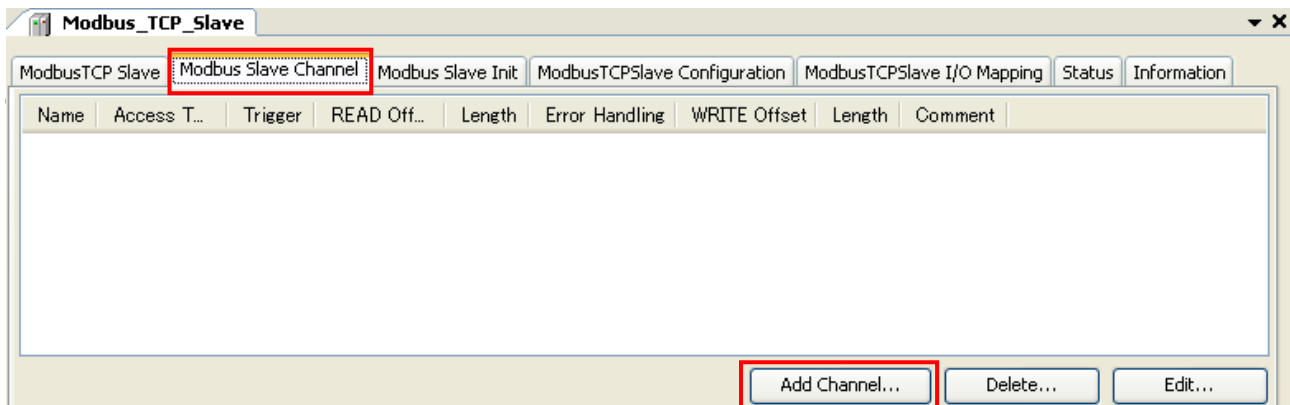

Configure each parameter as below. If the Trigger setting is “Rising edge”, trigger variable (BOOL) will be automatically assigned in %QX address.

Data of Modbus will be assigned to %IW or %QW as seen in “ModbusTCP Slave I/O Mapping” tab. Read data from slave is assigned to input area (%IW) and data to be written to slave is assigned to output area (%QW).

Variable	Mapping	Channel	Address	Type	Default Va...	Unit	Description
		Channel 1	%IW0	WORD			READ 16#0000 (=0000)
		Channel 2	%QX0.0	BIT			Trigger Variable
		Channel 2	%QW1	WORD			WRITE 16#0000 (=0000)

Note

- When trigger type is set as “Rising edge”, do not change the trigger bit too often, otherwise rising edge could be missed. Recommended timing is roughly calculated as follows.

T1 is the time from beginning of request to end of response per channel. If several channels are used, the sum of T1, T2, ..., Tn is the minimum time to keep low or high the trigger bit. But this is very approximate value and it is not easy to know T1. Recommended time would be 50 to 200ms or more depending on the number of channels.

- If long size data is sent from CPU in low baud rate (eg. 255 byte in 2,400 bps takes about 1 second.), 25 error (processor load watch dog) is detected independent from cycle time of bus cycle task because 25 error is detected based on percentage in 1 second. In this case, add following one line under [CmpSchedule] in config.cfg file. The value 2000 means 2 seconds. Please adjust this value accordingly. Refer to page 3-74 how to access and change config.cfg file.

[CmpSchedule]

ProcessorLoad.Interval=2000

- EHV-CPU ROM VER.3.4.x.x supports Modbus TCP master device V3.4. Refer to section 3.22 for further information.

3.15.3 Modbus-TCP slave (server)

Right click on “Ethernet” and choose “Add Device...”. Click “Modbus TCP Slave Device” in the “Add Device” window and [Add Device] button

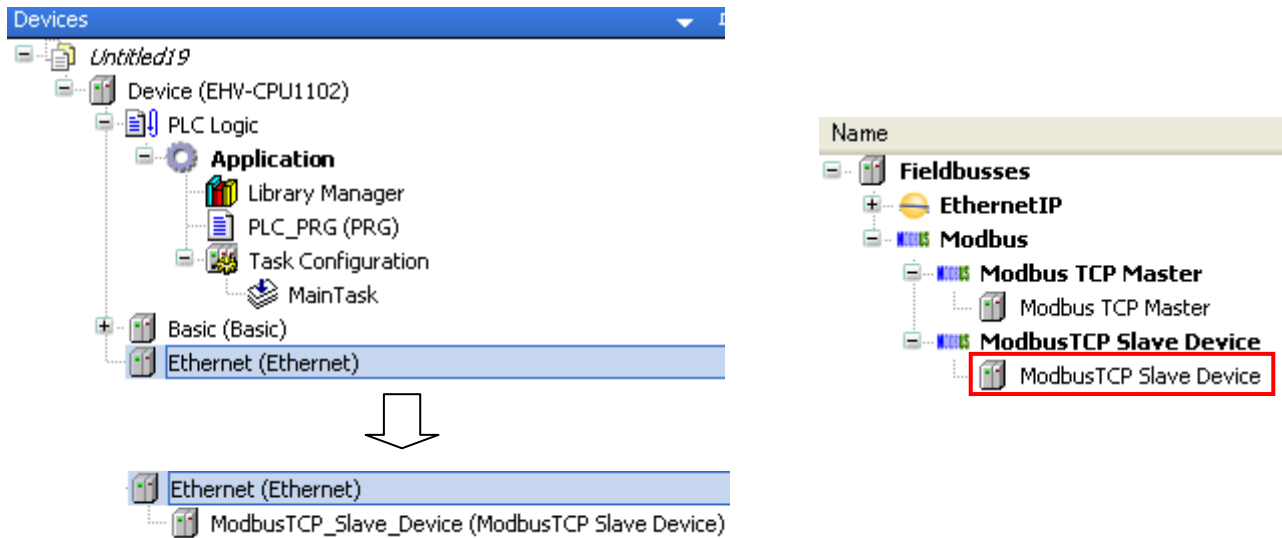

Configure each parameter as below. According to the size of “Holding Registers” and “Input Registers”, data area will be assigned as seen in “ModbusTCPSlave Device I/O Mapping” tab.

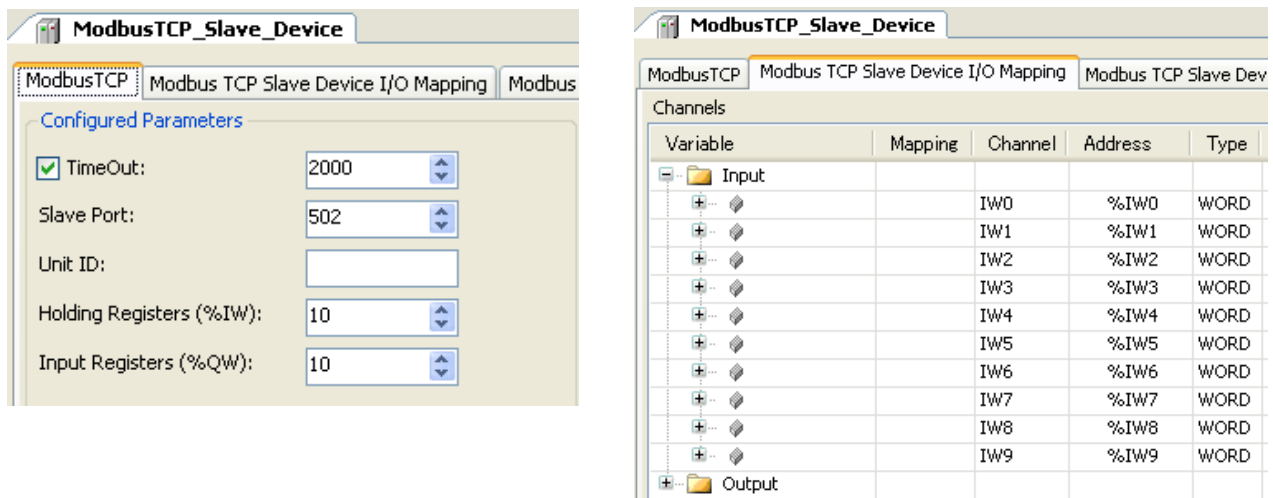

Note

- EHV-CPU ROM VER.3.4.x.x supports Modbus TCP slave device V3.4. Refer to section 3.22 for further information.
- Do not disconnect the cable while communication is running. Otherwise, correct data is not guaranteed.

3.15.4 Modbus-RTU master

Right click on “Device” and choose “Add Device...”.

“Add Device” window appears.

Click “Modbus COM” and [Add Device] button.

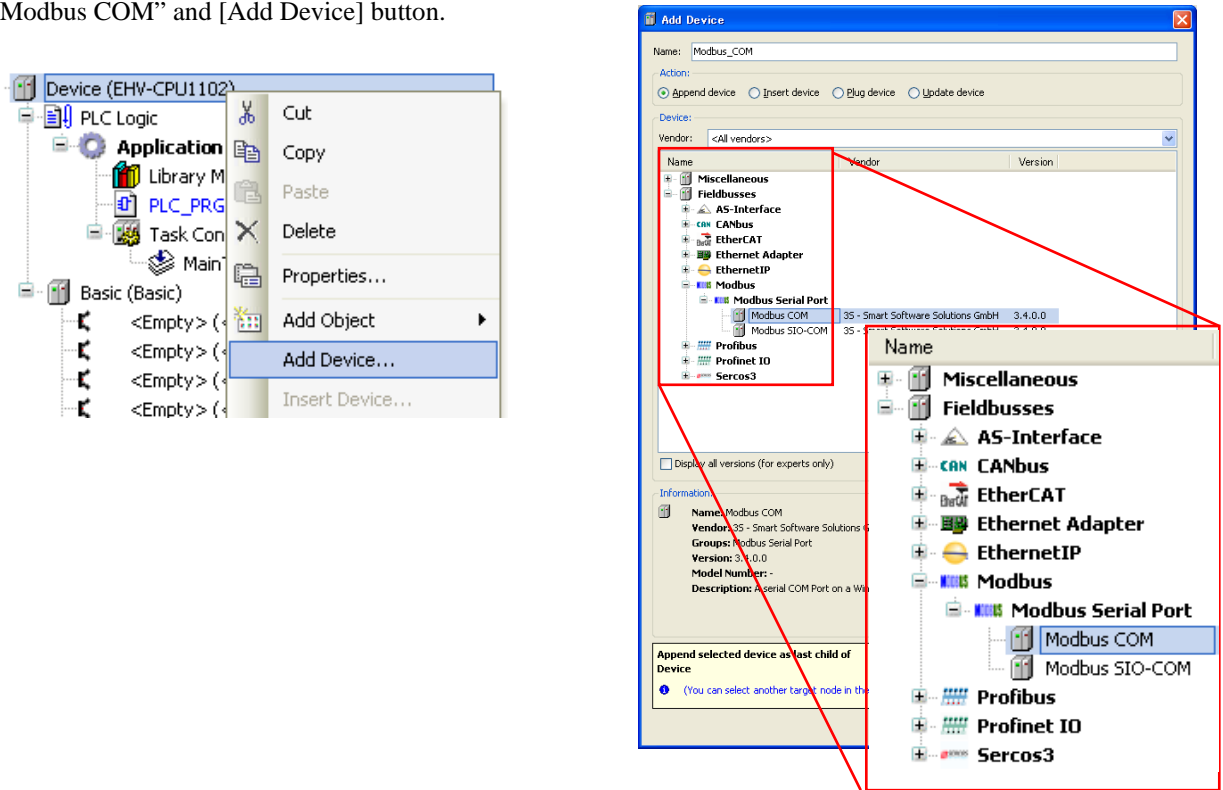

With “Add device” window opened, click “Modbus_COM” in the device tree. Then available devices will be shown in the “Add Device” window. Choose “Modbus Master, COM Port” and [Add Device] button

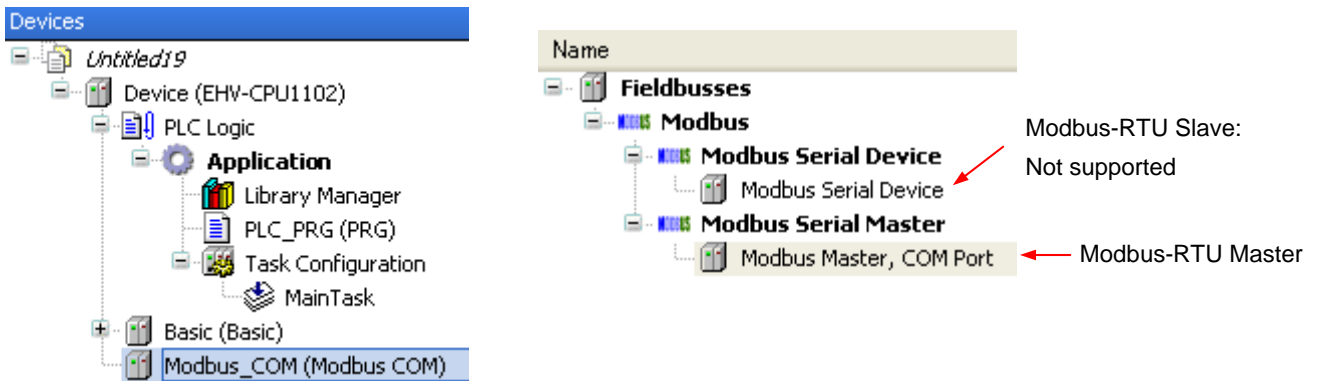

Note

- Although CPU’s Serial port does not support Modbus-RTU slave function, slave device (Modbus Serial Device) is available since it is common device for other manufacturer’s CODESYS based CPUs. Please do not choose this device with EHV+ series CPUs.
- EHV-CPU ROM VER.3.4.x.x supports Modbus RTU master device V3.4. Refer to section 3.22 for further information.

With “Add device” window opened, click “Modbus_Master_COM_Port” in the device tree. Then “Modbus Slave, COM Port” is shown in the “Add Device” window. Click “Modbus Slave, COM Port” and [Add Device] button according to your Modbus system configuration. e.g. if 3 slaves are to be controlled, add 3 times of slave devices.

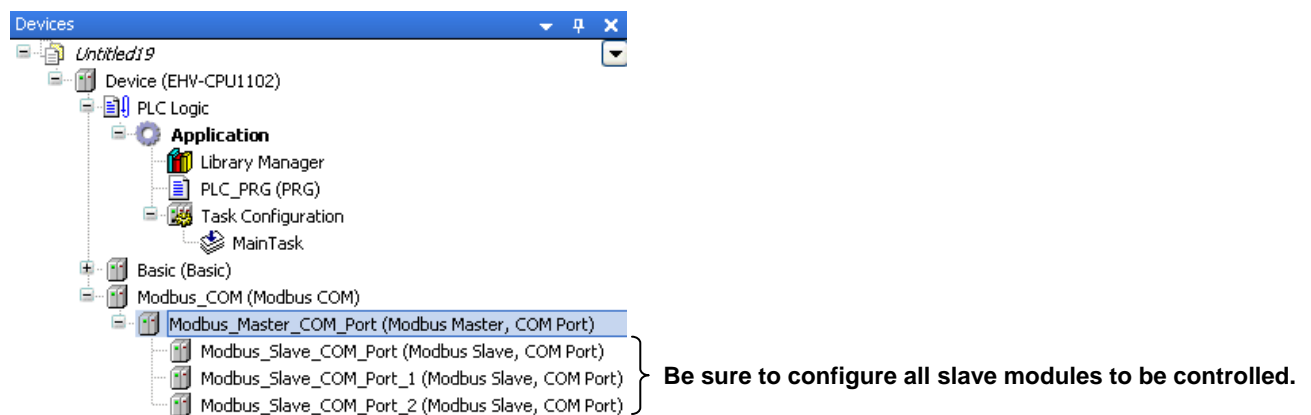
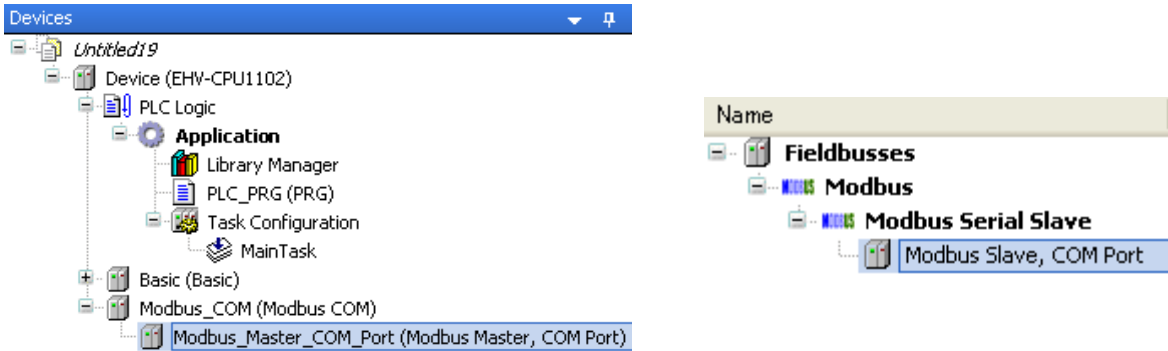

Function codes to be sent are configured in each slave. Double click a slave unit to open configuration window. Set slave address and response timeout.

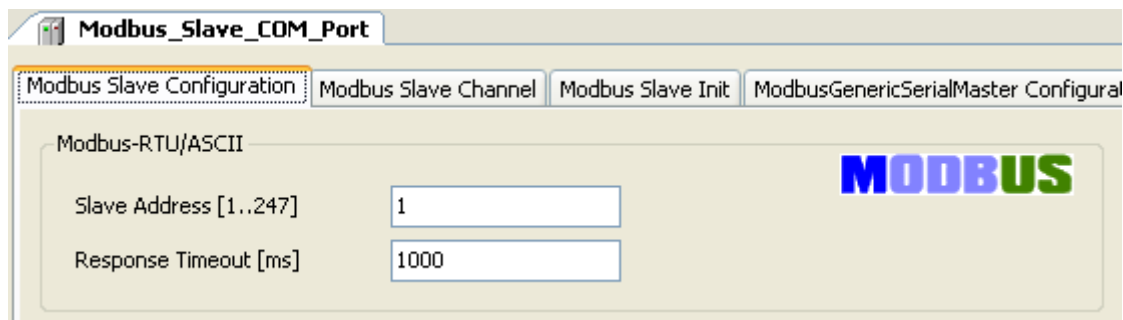

Open “Modbus Slave Channel” tab and click “Add Channel...” to add function codes.

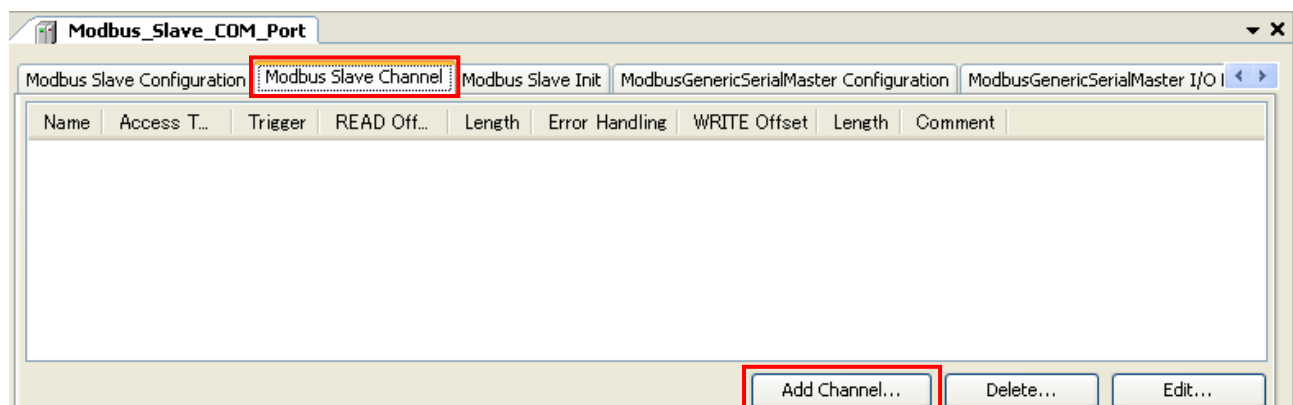

Configure each parameter as below. If the Trigger setting is “Rising edge”, trigger variable (BOOL) will be automatically assigned in %QX address.

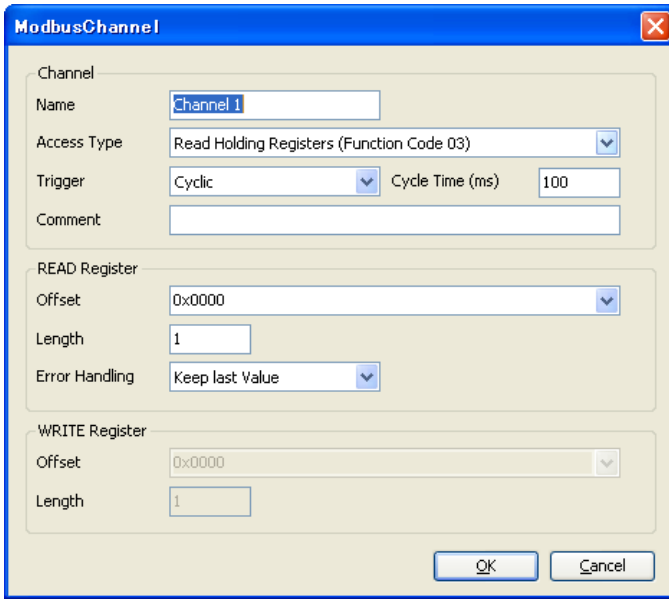

Data of Modbus will be assigned to %IW or %QW as seen in “ModbusGenericSerialMaster I/O Mapping” tab. Read data from slave is assigned to input area (%IW) and data to be written to slave is assigned to output area (%QW).

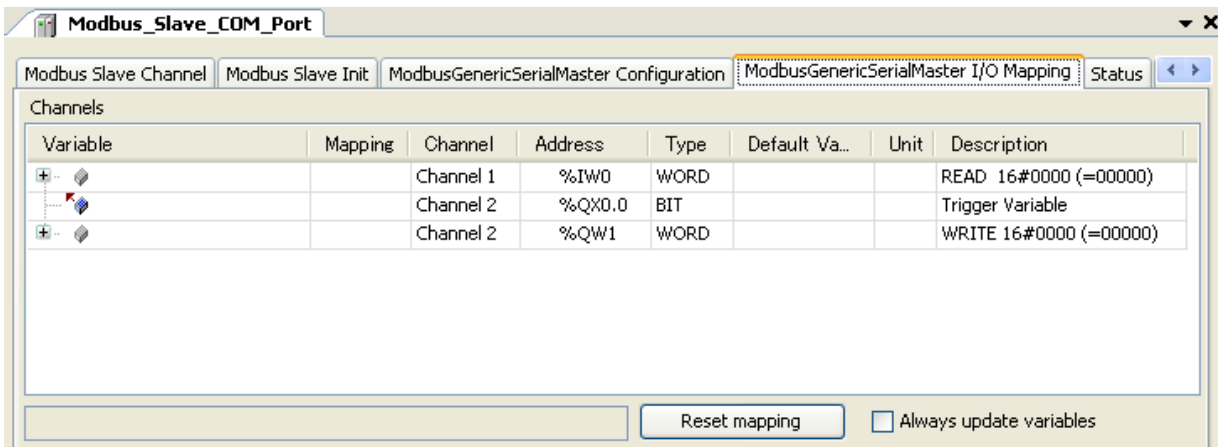

Note

When trigger type is set as “Rising edge”, do not change the trigger bit too often, otherwise rising edge could be missed. Recommended timing is roughly calculated as follows.

T1 is the time from beginning of request to end of response per channel. If several channels are used, the sum of T1, T2, ..., Tn is the minimum time to keep low or high the trigger bit. But this is very approximate value and it is not easy to know T1. Recommended time would be 50 to 200ms or more depending on the number of channels.

3.16 EH-SIO

3.16.1 Supported function

Any version of EH-SIO works with “EHV+” however, supported function is different from EHV/EH series as below.

Function	EHV+	EHV/EH-CPU
Modbus-RTU master	X	X
Modbus-ASCII master	-	X
Modbus-RTU/ASCII slave	-	X
General purpose communication (Free protocol)	X	X
Hi-Protocol	-	X
Simple data link	-	X

X = Supported, - = Not supported

3.16.2 Port number setting

Open “EH-SIO Configuration” window and set the port number from “COM2” to “COM15” (“COM1” is reserved for CPU local port) or “None”. Each COM port number must be unique. If it is duplicated, EH-SIO does not work.

Note

If a COM port of EH-SIO is not used, be sure to set “None”, otherwise EH-SIO does not work.

The diagram shows the EH-SIO configuration window with the following table:

Parameter	Type	Value	Default Value	Unit	Description
Bus cycle information for the io driver					
udiUnit	UDINT				
udiSlot	UDINT				
udiInputSize	UDINT				
udiOutputSize	UDINT				
COM port number [ch.1]	Enumeration of BYTE	None	COM2		Serial channel 1
COM port number [ch.2]	Enumeration of BYTE	COM3	COM3		Serial channel 2
Data Interval Time [ch.1]	byte	2	2		Data Interval Time: [1-255] x10ms
Data Interval Time [ch.2]	byte	2	2		Data Interval Time: [1-255] x10ms

The diagram also shows the hardware ports on the EH-CPU102. The CPU port “COM1” is fixed. EH-SIO port 1 and EH-SIO port 2 are shown, both set to “COM2” to “COM15” or “None”.

3.16.3 Modbus-RTU master

Right click on “Device” and choose “Add Device...”.

“Add Device” window appears.

Click “Modbus SIO-COM” and [Add Device] button.

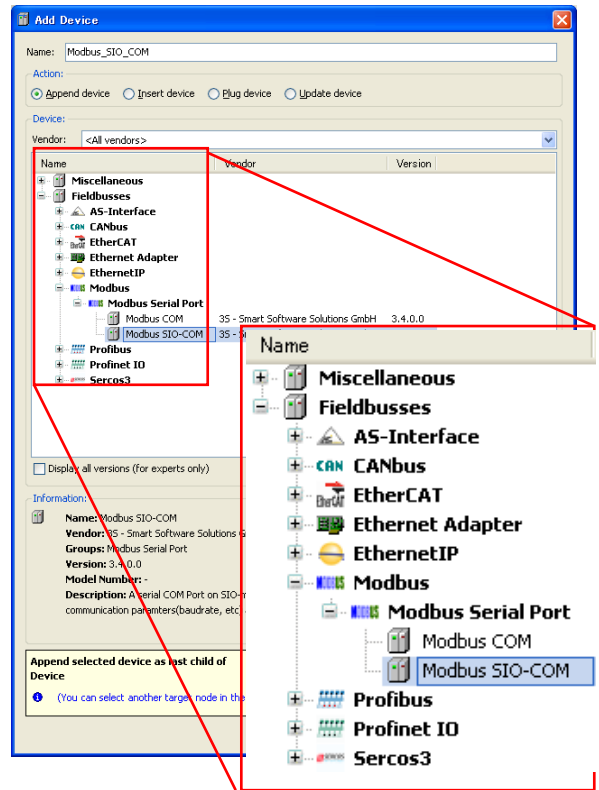
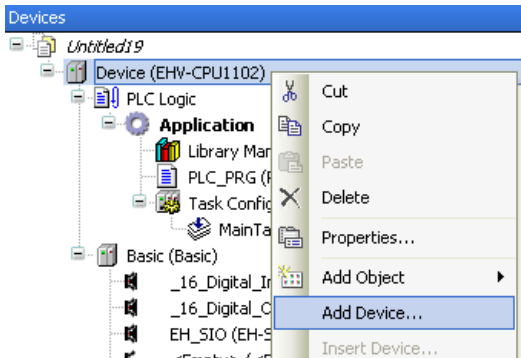

With “Add device” window opened, click “Modbus__SIO_COM” in the device tree. Then available devices will be shown in the “Add Device” window. Choose “Modbus Master, COM Port” and [Add Device] button

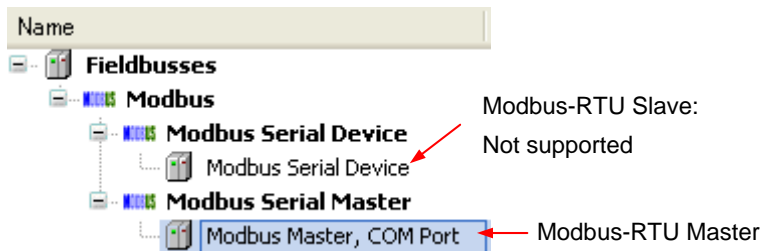
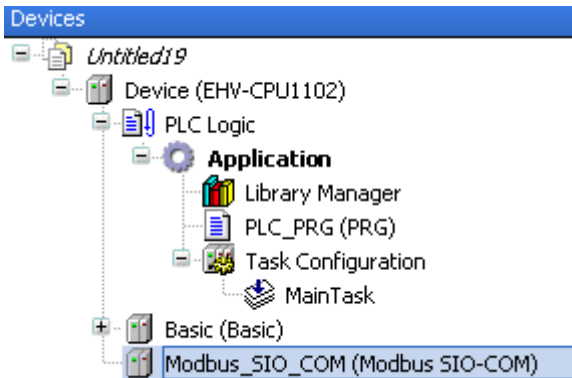

Note

- Although EH-SIO’s Serial port does not support Modbus-RTU slave function, slave device (Modbus Serial Device) is shown since it is common device for other manufacturer’s CODESYS based CPUs. Please do not choose this device.
- Modbus command processing is executed in bus cycle tack, which is configured in PLC settings of Device (refer to page 3-39). You can specify any existing IEC tasks. If the bus cycle task is <unspecified>, task with the shortest cycle time is taken. If 24 or 25 error appears in CPU, specify longer bus cycle task.
- EHV-CPU ROM VER.3.4.x.x supports Modbus RTU master device V3.4. Refer to section 3.22 for further information.

With “Add device” window opened, click “Modbus_Master_COM_Port” in the device tree. Then “Modbus Slave, COM Port” is shown in the “Add Device” window. Click “Modbus Slave, COM Port” and [Add Device] button according to your Modbus system configuration. e.g. if 3 slaves are to be controlled, add 3 times of slave devices.

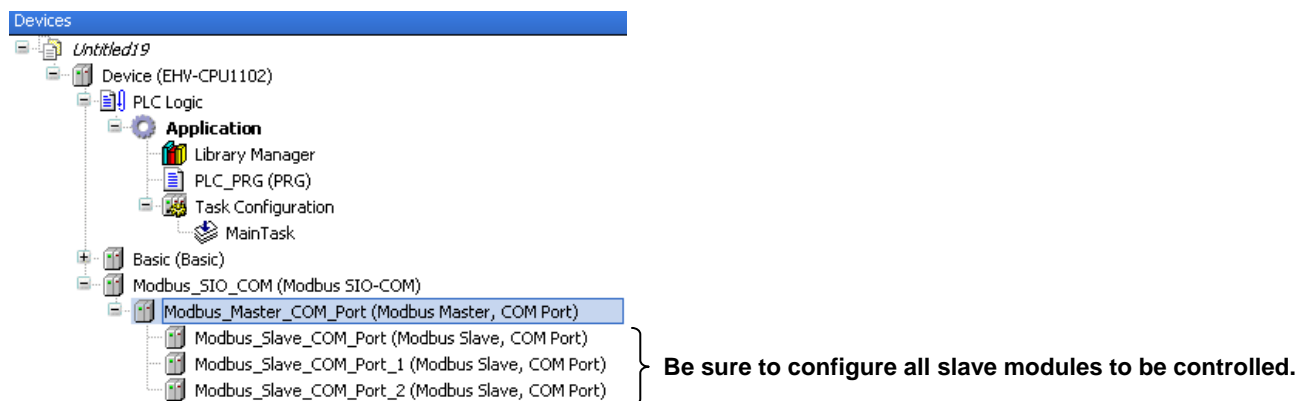
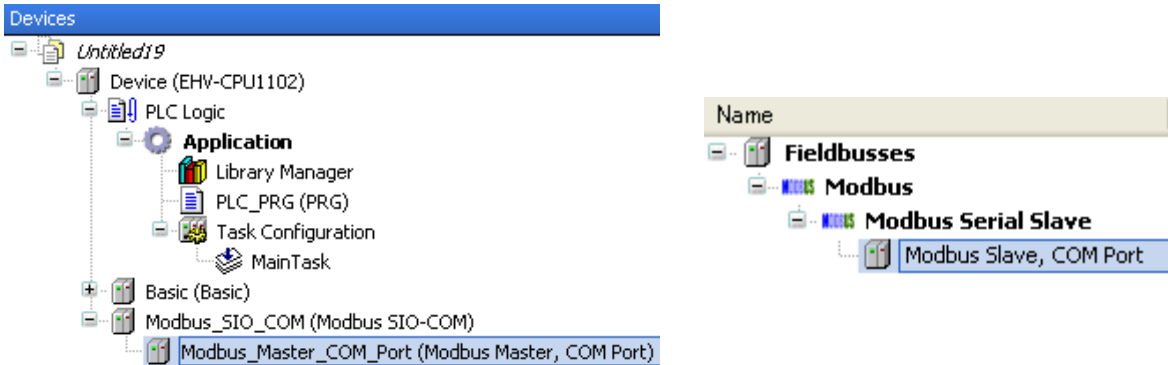

Double click on “Modbus_SIO_COM” or right click and choose “Edit Object.” Modbus_SIO_COM Configuration window appears. Set the same COM port number as “EH-SIO configuration” window. Although baud rate and data frame format of EH-SIO are configured with dip switches on board, set same parameters as dip switches in this configuration window too.

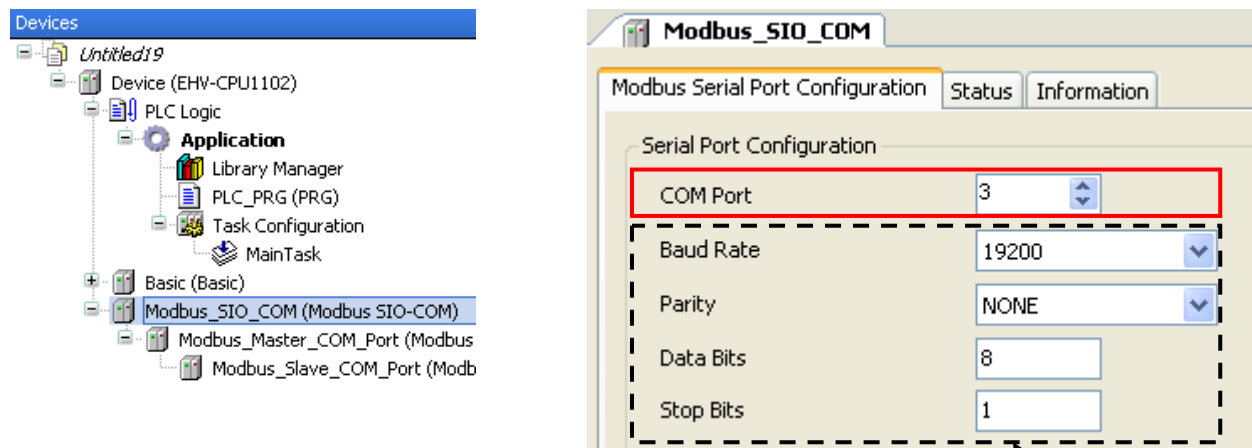

Modbus operation is same as CPU port. Refer to page 3-46 for further information.

Set same data as dip switches on board.

Note

In higher baud rate, such as 57.6 or 115.2kbps, if slave device responds less than 1ms, CPU might fail to receive a query. In this case, change the baud rate to slower.

3.16.4 General purpose communication

Besides Modbus-RTU function, EH-SIO supports general purpose communication same as CPU port.

Add “SysCom” library by clicking “Add library” on Library manager. Only the difference from CPU port is COM port number. Be sure to set the same COM port number as “EH-SIO configuration” window. Refer to section 3.19.3 Serial communication for further information.

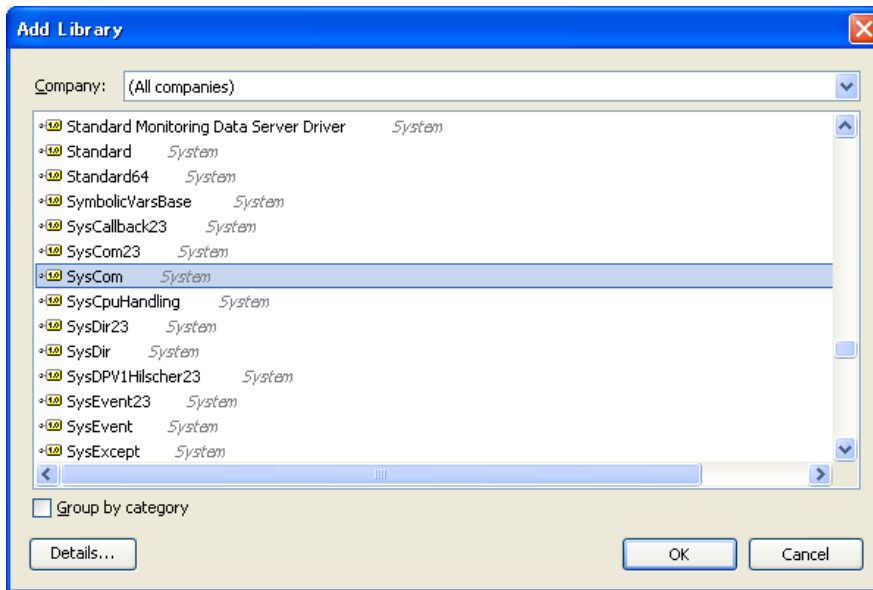

3.16.5 LED indication

MB and MS LED: When CPU has no application (user program) or wrong COM port setting or “None” assigned, LNK, MB, HP and MS LED will light up. If correct COM port setting is downloaded, all of the LED will turn off. (Even EH-SIO works in Modbus-RTU mode, internal setting of EH-SIO is always general purpose mode. For this reason, MB and MS LED do not light.)

CDE LED: Even if correct COM port setting is downloaded, CDE LED will light up without cable connected because DR signal is expected to be high in RS-232C port.

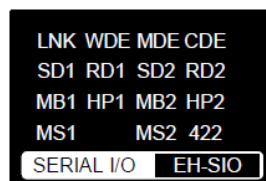

LNK ... Link mode
 WDE ... Watch dog timer error
 MDE ... Module error
 CDE ... Command error
 SD1/2 ... Sending data
 RD1/2 ... Receiving data
 MB1/2 ... Modbus mode
 HP1/2 ... Hi-Protocol mode
 MS1/2 ... Modbus Master
 422 ... RS-422 port enabled

3.16.6 Hardware reset and Software reset

When the reset button is pressed while communication, the communication is aborted since EH-SIO is initialized. This is hardware reset operation. Make stop and run to recover the communication.

Instead of that, SysComPurge command is able to initialize EH-SIO. This is software reset function.

3.17 CPU LINK module

3.17.1 Supported CPU version

EHV+ series CPU has supported CPU-LINK module since ROM VER.3.4.4.0. Due to this improvement, the configuration of EH-RMP (Profibus-DP master module) has changed also as below. If you use EH-RMP with CPU of ROM VER.3.4.4.0 or newer, be sure to configure EH-LNK in EHV-CODESYS instead of EH-RMP.

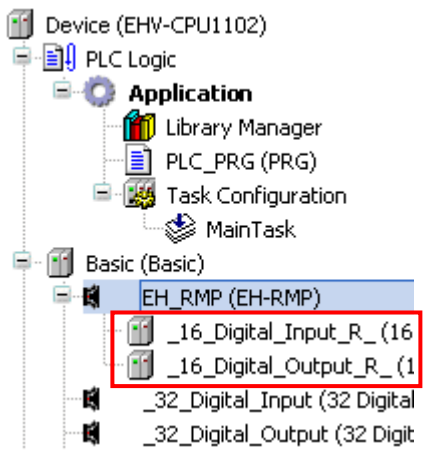
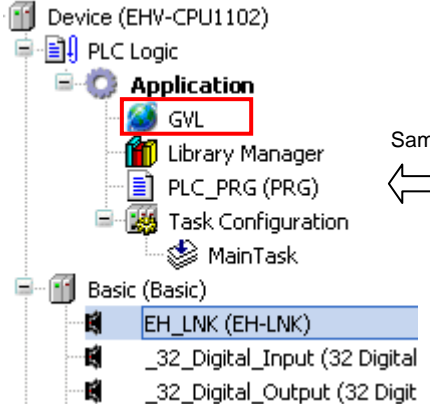
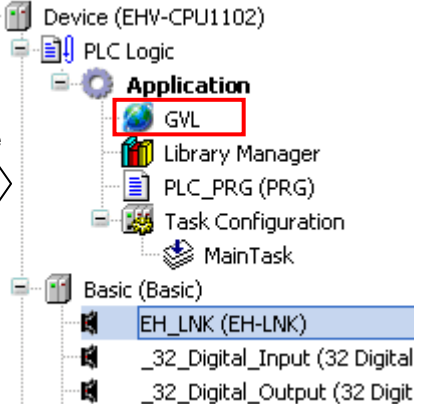
	Configuration of EH-RMP	Configuration of EH-LNK, OLNK
CPU ROM VER.3.4.1.3 or older		Not available
CPU ROM VER.3.4.4.0 or newer		

In the CPU LINK network, all the connected CPU share a common memory called LINK area. This LINK area is accessible by using %M address in global variable list (GVL). The address of %M is common for all the CPU. GVL can be added by right clicking on “Application” as below.

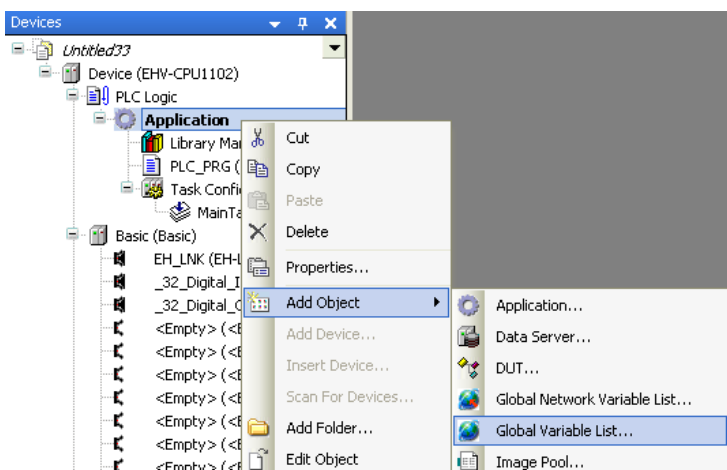

3.17.2 Configuration of LINK parameters

Open “EH-LNK Configuration” window and set Writing area %MW-address and Writing area size.

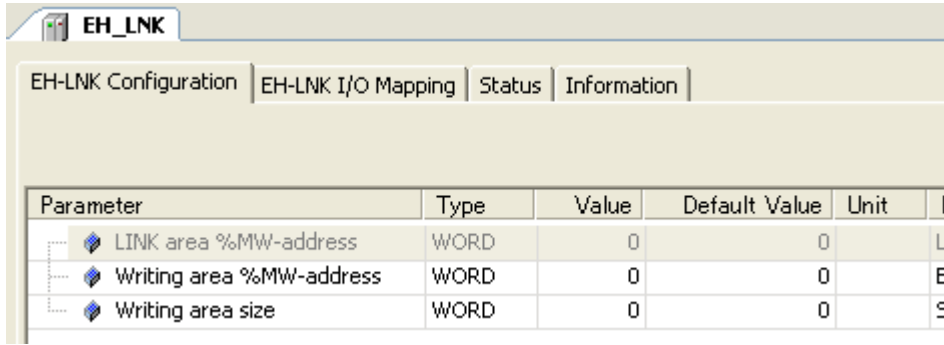

Example

Below figure is an example of 3 CPUs. Each LINK module has own writing area in the LINK area, which must not be overlapped. Writing area for one CPU is automatically reading area for the other CPUs.

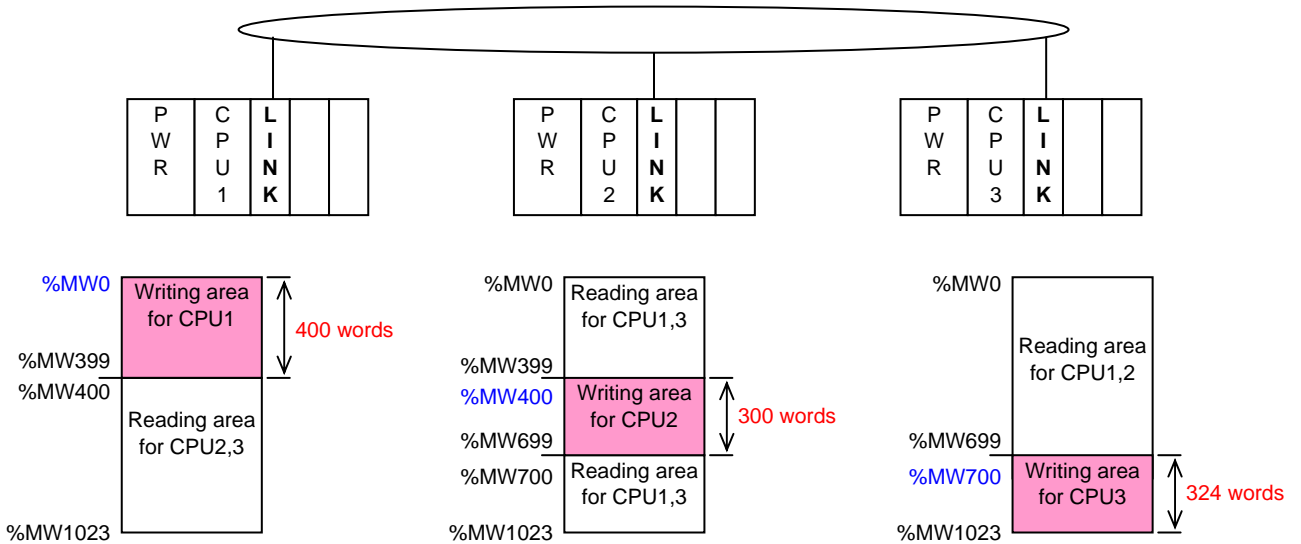

	CPU1	CPU2	CPU3
Writing area %MW-address	0	400	700
Writing area size	400	300	324

If only one LINK module is used per CPU, the address of LINK area is from %MW0 to %MW1023. If several LINK modules are used, the addresses are as below. The address is NOT depending on mounted slot number but the number of LINK modules.

	LINK-1	LINK-2	LINK-3	LINK-4	LINK-5	LINK-6	LINK-7	LINK-8
From	%MW0	%MW1024	%MW2048	%MW3072	%MW4096	%MW5120	%MW6144	%MW7168
To	%MW1023	%MW2047	%MW3071	%MW4095	%MW5119	%MW6143	%MW7167	%MW8191

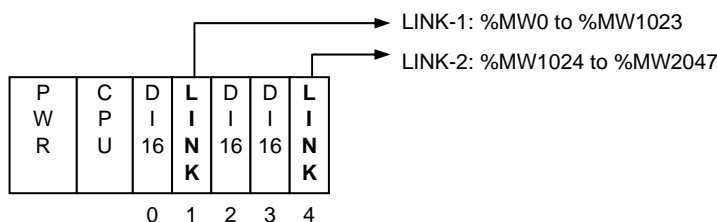

3.17.3 Declaration of variables

Same as other normal variables, Auto Declare window appears if the variable is newly used in POU. Choose VAR_GLOBAL in Scope and set %MW address in Address field as below. Then it is defined in GVL automatically.

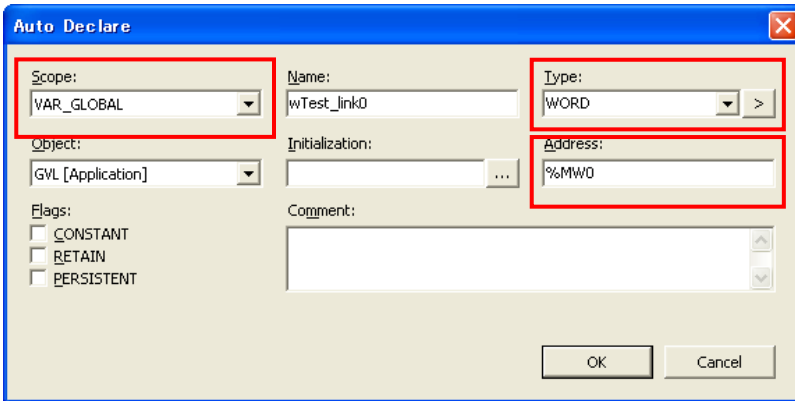

```

1  VAR_GLOBAL
2     wTest_link0 AT %MW0: WORD;
3  END_VAR
    
```

BOOL and BYTE address of %M are available as below.

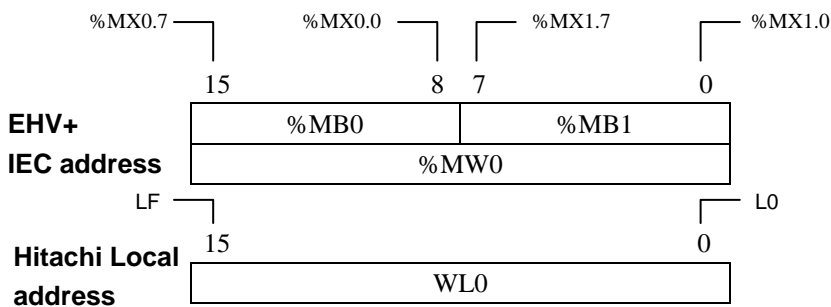

Note

DWORD data is not compatible between EHV+ and existing Hitachi LINK address.

%MD0 = 16#1234 5678 → DL0 = H5678 1234

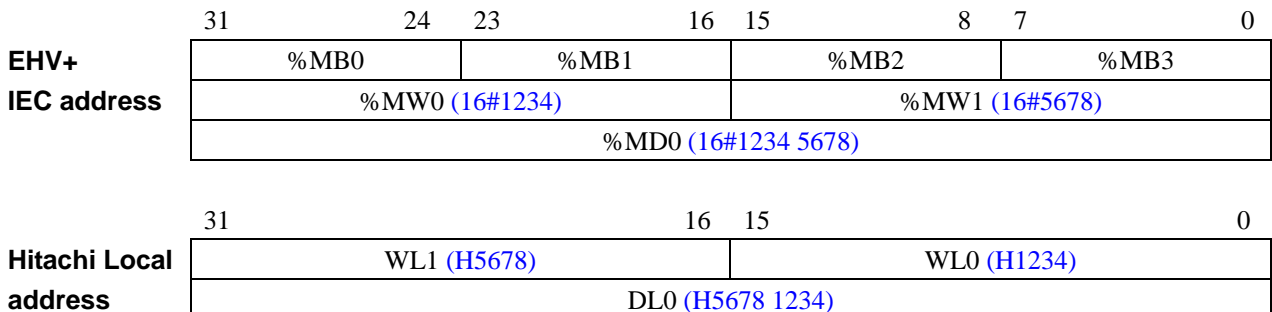

IEC address is decimal and Hitachi LINK address is hexa-decimal as below.

IEC address			Hitachi local address	
Bool	Byte	Word	Bool	Word
%MX1.0	%MB1	%MW0	L0000	WL000
%MX1.1			L0001	
%MX1.2			L0002	
%MX1.3			L0003	
%MX1.4			L0004	
%MX1.5			L0005	
%MX1.6			L0006	
%MX1.7	L0007			
%MX0.0	%MB0	%MW0	L0008	
%MX0.1			L0009	
%MX0.2			L000A	
%MX0.3			L000B	
%MX0.4			L000C	
%MX0.5			L000D	
%MX0.6			L000E	
%MX0.7	L000F			
%MX3.0 to 3.7	%MB3	%MW1	L0010 to 001F	WL001
%MX2.0 to 2.7	%MB2			
%MX5.0 to 5.7	%MB5	%MW2	L0020 to 002F	WL002
%MX4.0 to 4.7	%MB4			
%MX7.0 to 7.7	%MB7	%MW3	L0030 to 003F	WL003
%MX6.0 to 6.7	%MB6			
...
%MX2045.0 to 2045.7	%MB2045	%MW1022	L3FE0 to 3FEF	WL3FE
%MX2044.0 to 2044.7	%MB2044			
%MX2047.0 to 2047.7	%MB2047	%MW1023	L3FF0 to 3FFF	WL3FF
%MX2046.0 to 2046.7	%MB2046			

Note

If CPU LINK module is not used, %M address can be used as internal registers.

3.17.4 Configuration of EH-RMP [CPU ROM VER.3.4.1.3 or older]

Separate configuration by Sycon is required for EH-RMP. In EHV-CODESYS, total size of input and output must be configured by adding digital in/output 16 module. Choose “Add Device” on EH-RMP and choose digital input 16 or digital output 16 module according to actual total size of slave units.

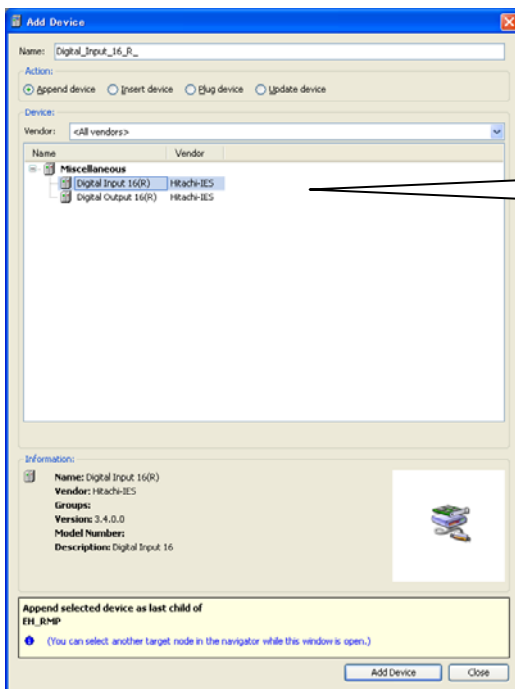
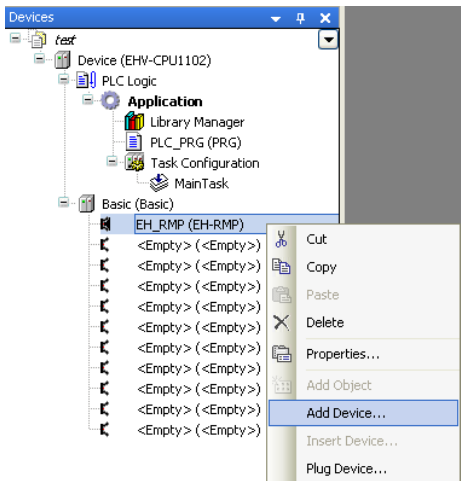

Name	Vendor	Version
Miscellaneous		
16 Digital Input(R)	Hitachi-IES	3.4.0.0
16 Digital Output(R)	Hitachi-IES	3.4.0.0

Note

- Any types of slave units are available for EH-RMP, but only digital input 16 and digital output 16 module can be configured under EH-RMP in EHV-CODESYS. Configure those modules according to total input and output size. For example, if the total input and output size of slave modules are 4 and 8 words, configure 4 times of Digital Input 16 (R) and 8 times of Digital Output 16 (R) under EH-RMP.
- Be sure to mount EH-RMP on slot 0 to 7 of basic base although it can be configured on slot 8 to A in EHV-CODESYS.

[CPU ROM VER.3.4.4.0 or newer]

Configuration of EH-RMP/2 has been changed as same as EH-LNK module. Besides below settings, separate configuration by Sycon is required for EH-RMP/2.

Variable declaration in GVL

Be sure to add Global Variable List (GVL) as described in the section 3.17.1 and declare variables at %M address as below.

```

GVL
1  VAR_GLOBAL
2  Alarm AT %MX1.0: BOOL;
3  Sensor AT %MX1025.0: BOOL;
4  END_VAR
    
```

Link parameters

Choose EH-LNK in Plug Device and double click it or right click and choose “Edit Object”. EH-LNK Configuration window appears as below. Set Writing area %MW address and Writing area size.

Writing area %MW-address

Set the starting address of LINK area. If only one EH-RMP/2 is used, set 0.

Writing area size

EH-RMP: Set actually used size (configured by Sycon) for output modules.

EH-RMP2: Set “512” always.

Note

Do not set “0” in Writing area size. If all the slaves are input units and no output unit is used, please set a dummy value except 0, otherwise status LED on EH-RMP blinks four times. In case of EH-RMP2, be sure to set 512, otherwise status LED blinks four times.

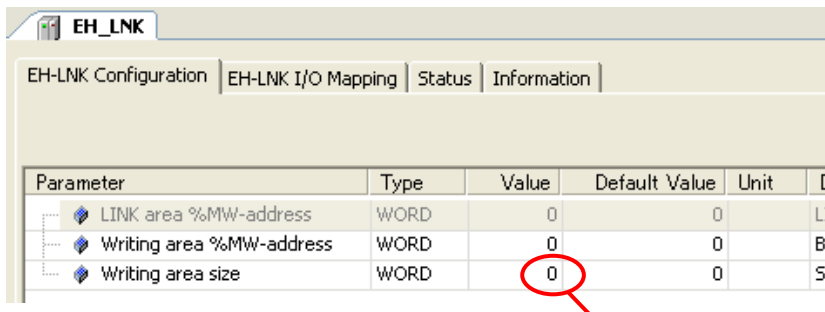

X words (EH-RMP) or 512 words (EH-RMP2)

Address of reading area (not necessary to set)

Reading area for input modules is automatically assigned as follows.

Word address	Bit address	Hitachi adr.	Description (EH-RMP)	Description (EH-RMP2)
%MW0	%MX1.0-7, 0.0-7	WL0	[X] words for Writing area	512 words for Writing area
%MW1	%MX3.0-7, 2.0-7	WL1		
%MW2	%MX5.0-7, 4.0-7	WL2		
%MW[X]				
...			Possible to configure for writing area	
%MW255	%MX511.0-7, 510.0-7	WLFF	Not available in EH-RMP (256 words)	
%MW256	%MX513.0-7, 512.0-7	WL100		
...				
%MW511	%MX1023.0-7, 1022.0-7	WL1FF	256 words for Reading area	512 words for Reading area
%MW512	%MX1025.0-7, 1024.0-7	WL200		
...				
%MW767	%MX1535.0-7, 1534.0-7	WL2FF		
%MW768	%MX1537.0-7, 1536.0-7	WL300	Not available in EH-RMP (256 words)	
...				
%MW1023	%MX2047.0-7, 2046.0-7	WL3FF		

3.17.5 Configuration of EH-RMD

Configuration of EH-RMD has been changed as same as EH-LNK module. Besides below settings, separate configuration is required for EH-RMD.

Variable declaration in GVL

Be sure to add Global Variable List (GVL) as described in the section 3.17.1 and declare variables at %M address as below.

```

GVL
1  VAR_GLOBAL
2  Alarm AT %MX1.0: BOOL;
3  Sensor AT %MX1025.0: BOOL;
4  END_VAR

```

Link parameters

Choose EH-LNK in Plug Device and double click it or right click and choose “Edit Object”. EH-LNK Configuration window appears as below. Set Writing area %MW address and Writing area size.

Writing area %MW-address

Set the starting address of LINK area. If only one EH-RMD is used, set 0.

Writing area size

Set “512” always.

Note

Do not set “0” in Writing area size, otherwise status LED on EH-RMD blinks four times.

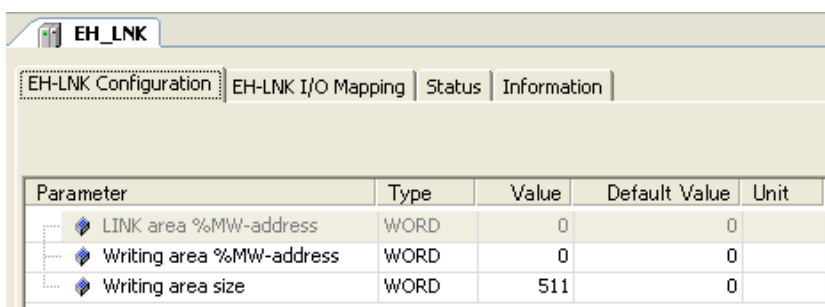

Parameter	Type	Value	Default Value	Unit
LINK area %MW-address	WORD	0	0	
Writing area %MW-address	WORD	0	0	
Writing area size	WORD	511	0	

Address of reading area (not necessary to set)

Reading area for input modules is automatically assigned from %MW512 to %MW767.

Word address	Bit address	Hitachi adr.	Description
%MW0	%MX1.0-7, 0.0-7	WL0	256 words for Writing area
%MW1	%MX3.0-7, 2.0-7	WL1	
%MW2	%MX5.0-7, 4.0-7	WL2	
...			
%MW255	%MX511.0-7, 510.0-7	WLFF	
%MW256	%MX513.0-7, 512.0-7	WL100	256 words for explicit message
...			
%MW511	%MX1023.0-7, 1022.0-7	WL1FF	
%MW512	%MX1025.0-7, 1024.0-7	WL200	256 words for Reading area
...			
%MW767	%MX1535.0-7, 1534.0-7	WL2FF	256 words for explicit message
%MW768	%MX1537.0-7, 1536.0-7	WL300	
...			
%MW1023	%MX2047.0-7, 2046.0-7	WL3FF	

3.17.6 Library of LINK and Profibus module

Several useful libraries are available for CPU LINK module and Profibus module as below.

LinkModuleError (detected by CPU)

I/O type	Name	Type	Description
Input	-		
Output	xError	BOOL	LINK module error
	bySlotNo	BYTE	Slot number

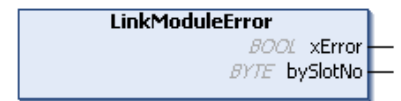

GetLinkInfo (detected by CPU LINK module)

I/O type	Name	Type	Description
Input	byLinkNo	BYTE	LINK number (1 to 8)
Output	xDone	BOOL	Library execution completed
	xError	BOOL	Library execution error
	LinkInfo	STRUCT	LINK information



Details of STRUCT LinkInfo

Name	Type	Description
xSystemBusError	BOOL	System bus error flag
xLinkAreaSettingError	BOOL	Link area setting is out of the range.
xLinkAreaOverlapError	BOOL	Link area is overlapped.
xStationNumberError	BOOL	Station number is out of the range.
xCableDisconnection	BOOL	Link cable is disconnected.
byCableDscnNumber	BYTE	Station number of cable disconnection
lwLinkFlag	LWORD * ¹	Link participation flag for st. 0 to 63 (1:Participation, 0:Not participation)
lwLinkStatus	LWORD * ¹	Link operation flag for st. 0 to 63 (1: In operation, 0: Not operation)
lwCPUStatus_RUN	LWORD * ¹	CPU RUN status for st. 0 to 63 (1: RUN, 0: STOP)
lwCPUStatus_HALT	LWORD * ¹	CPU HALT status for st. 0 to 63 (1: HALT, 0: Not HALT)
lwCPUStatus_Err	LWORD * ¹	CPU Error status for st. 0 to 63 (1: Error, 0: No error)
lwErrorFlag	LWORD * ¹	LINK Error flag for st. 0 to 63 (1: Error, 0: No error)
lwErrInfo_1	LWORD * ¹	LINK error information 1 for st. 0 to 63 (1: Error between LINK and CPU, 0: No error)
lwErrInfo_2	LWORD * ¹	LINK error information 2 for st. 0 to 63 (1: Framing error, 0: No error)
lwErrInfo_3	LWORD * ¹	LINK error information 3 for st. 0 to 63 (1: Timeout error, 0: No error)
byNo_of_ComErr[0..63]	ARRAY OF BYTE * ²	The number of communication error for st. 0 to 63
wCycleTime_Max	WORD	LINK refresh time (max.)
wCycleTime_Min	WORD	LINK refresh time (min.)
wCycleTime_Now	WORD	LINK refresh time (current)

*1 Each bit of 64-bit data is corresponding to station number from 0 to 63. Bit data is accessible by adding dot and bit number for example, "lwLinkFlag.5" for station number 5.

*2 Each byte of 64-byte array data is corresponding to station number from 0 to 63.

GetProfibusInfo (detected by EH-RMP/2 module)

I/O type	Name	Type	Description
Input	byLinkNo	BYTE	LINK number (1 to 8)
Output	xDone	BOOL	Library execution completed
	xError	BOOL	Library execution error
	ProfibusInfo	STRUCT	Profibus information

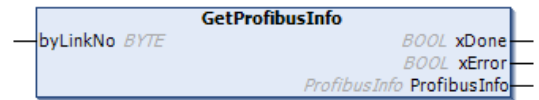

Details of STRUCT ProfibusInfo

Name	Type	Description
wErrorCode	WORD	Error code
byMainState	BYTE	Status of EH-RMP/2
byGlobalErrorBits	BYTE	Global error information
byErrorNumber	BYTE	Error code of internal (master) or external (slave) error (only EH-RMP)
byErrorRemoteAddress	BYTE	Slave address in error status. (If 0xFF, then error is in master) (only EH-RMP)
wHeavyBusErrorCount	WORD	The number of serious bus error
wNumRejectedProfibusTelegrams	WORD	The number of rejected Profibus telegrams
wSlaveConfig0_15	WORD * ¹	Bit 0 to 15 is for slave adr. 0 to 15. If bit is TRUE, the slave is configured.
wSlaveConfig16_31	WORD * ¹	Bit 0 to 15 is for slave adr. 16 to 31. If bit is TRUE, the slave is configured.
wSlaveConfig32_47	WORD * ¹	Bit 0 to 15 is for slave adr. 32 to 47. If bit is TRUE, the slave is configured.
wSlaveConfig48_63	WORD * ¹	Bit 0 to 15 is for slave adr. 48 to 63. If bit is TRUE, the slave is configured.
wSlaveConfig64_79	WORD * ¹	Bit 0 to 15 is for slave adr. 64 to 79. If bit is TRUE, the slave is configured.
wSlaveConfig80_95	WORD * ¹	Bit 0 to 15 is for slave adr. 80 to 95. If bit is TRUE, the slave is configured.
wSlaveConfig96_111	WORD * ¹	Bit 0 to 15 is for slave adr. 96 to 111. If bit is TRUE, the slave is configured.
wSlaveConfig112_127	WORD * ¹	Bit 0 to 15 is for slave adr. 112 to 127. If bit is TRUE, the slave is configured.
wSlaveState0_15	WORD * ¹	Bit 0 to 15 is for slave adr. 0 to 15. If bit is TRUE, the slave is in active status.
wSlaveState16_31	WORD * ¹	Bit 0 to 15 is for slave adr. 16 to 31. If bit is TRUE, the slave is in active status.
wSlaveState32_47	WORD * ¹	Bit 0 to 15 is for slave adr. 32 to 47. If bit is TRUE, the slave is in active status.
wSlaveState48_63	WORD * ¹	Bit 0 to 15 is for slave adr. 48 to 63. If bit is TRUE, the slave is in active status.
wSlaveState64_79	WORD * ¹	Bit 0 to 15 is for slave adr. 64 to 79. If bit is TRUE, the slave is in active status.
wSlaveState80_95	WORD * ¹	Bit 0 to 15 is for slave adr. 80 to 95. If bit is TRUE, the slave is in active status.
wSlaveState96_111	WORD * ¹	Bit 0 to 15 is for slave adr. 96 to 111. If bit is TRUE, the slave is in active status.
wSlaveState112_127	WORD * ¹	Bit 0 to 15 is for slave adr. 112 to 127. If bit is TRUE, the slave is in active status.
wDeviceError	WORD	Error code of master unit (only EH-RMP)
wRefreshingTimeMax	WORD	Max. refresh cycle time
wRefreshingTimeMin	WORD	Min. refresh cycle time
wRefreshingTimeNow	WORD	Current refresh cycle time

*1 Each bit of 16-bit data is corresponding to station number. Bit data is accessible by adding dot and bit number for example, "wSlaveConfig0_15.5" for address 5.

3.18 EtherCAT master function

3.18.1 Installation of libraries (for EHV-CoDeSys V3.4)

Before using EtherCAT function, be sure to install the latest libraries according to the below steps.

(1) Choose [Tools]-[Package Manager...]

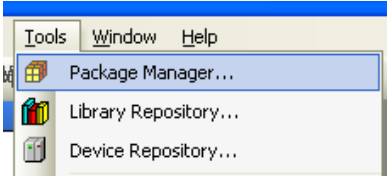

(2) Click “Install new packages”

(3) Click “CD or disk...” and choose the file “Hitachi_201209E.package”. If you don’t have it, ask your local supplier.

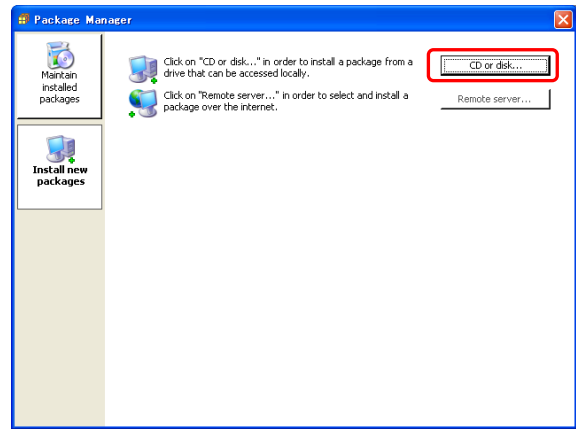
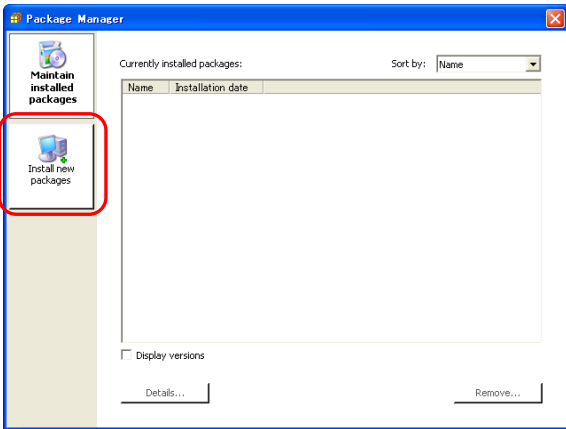

(4) If below information is displayed, the package is successfully installed.

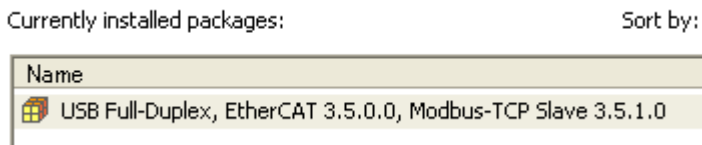

The following libraries and file are included in this package.

File name	Version	Description
IoDrvEtherCAT	3.5.0.0	EtherCAT library (EHV+ CPU supports this version or higher.)
ModbusTCPSlave	3.5.1.0	Modbus-TCP slave library (bug fix)
EHV-CPU1102	3.4.4.1	CPU Device description file supporting EtherCAT
EHV-CPU1025	3.4.4.1	CPU Device description file supporting EtherCAT
Gateway.cfg	-	USB full duplex mode supported

Note

Full duplex mode of USB has been supported since CPU ROM VER.3.4.4.4 for better and stable communication performance. After this package installed, it is not possible to connect to the older CPU in USB. When older CPU is used with USB, uninstall this package by choosing [Remove] button in the Package Manager dialog box or ask your local supplier.

3.18.2 Supported CPU version

The Ethernet port of EHV+ series CPU has supported EtherCAT master function since ROM VER.3.4.4.4.

3.18.3 Configuration

Right click on “Device” and “Add Device...”.

“Add Device” window appears.

Click “EtherCAT Master” and [Add Device] button.

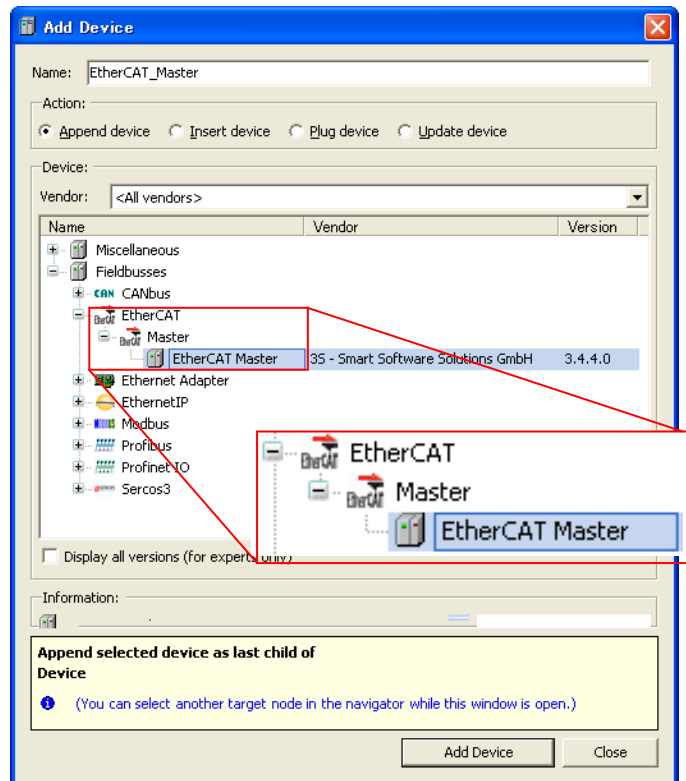
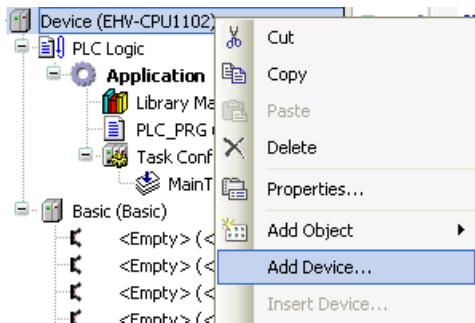

With “Add device” window opened, click “EtherCAT_Master” in the device tree. Then available devices will be shown in the “Add Device” window. Click slave units according to your system configuration and [Add Device] button.

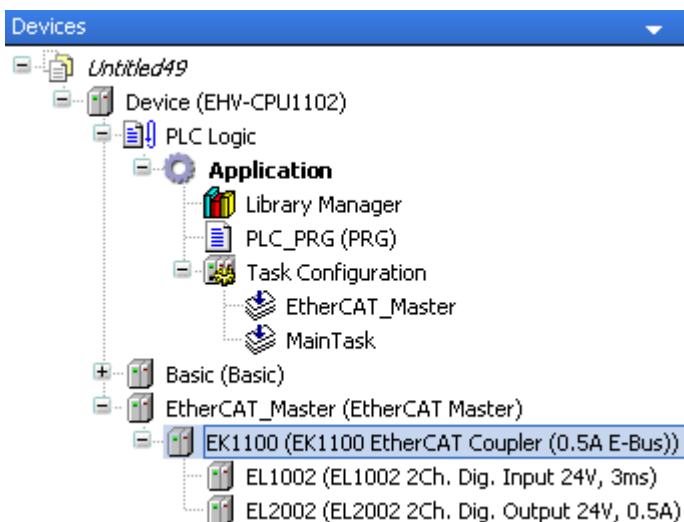

If requested slave unit is not found in the “Add Device” window, ESI file (XML file) is missing. Get it from slave suppliers and install by choosing [Tools]-[Device Repository...].

3.18.4 Online settings

Open communication to CPU according to the section 3.8 Communication settings.

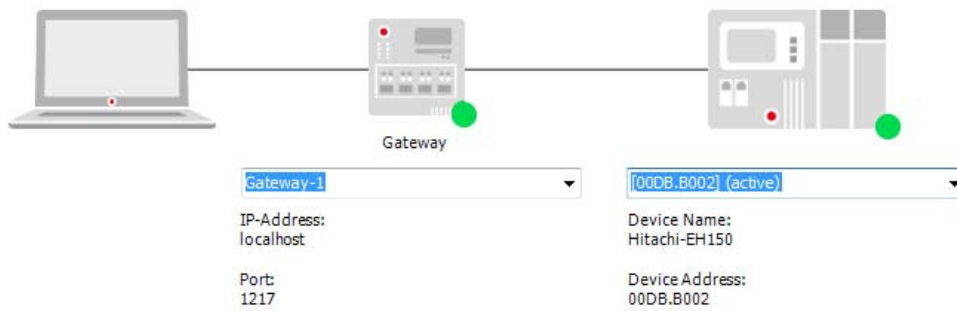

Double click on EtherCAT_Master or right click and choose “Edit Object” to open EtherCAT_Master window. Click “Browse” button.

EtherCAT_Master

Master | EtherCAT I/O Mapping | Status | Information

Autoconfig Master/Slaves

EtherCAT NIC Setting

Destination Address (MAC) FF-FF-FF-FF-FF-FF Broadcast

Source Address (MAC) 00-00-00-00-00-00 **Browse...**

Network Name

Select network by MAC Select network by Name

Distributed Clock

Cycletime 4000 μ s

Sync Offset 20 %

Options

Use LRW instead of LWR/LRD

Enable messages per task

Auto restart slaves

If active path is correctly set, the CPU is detected in “Select Network Adapter” dialog box as below. Click [OK] to set the MAC address of the CPU in “Source Address (MAC)” as below.

Select Network Adapter

00F8E63FE59F

name: EHV+ Ethernet interface

description: EHV+ Ethernet interface

OK Abort

EtherCAT_Master

Master | EtherCAT I/O Mapping | Status | Information

Autoconfig Master/Slaves

EtherCAT NIC Setting

Destination Address (MAC) FF-FF-FF-FF-FF-FF Broadcast

Source Address (MAC) **00-F8-E6-3F-E5-9F** **Browse...**

Network Name EHV+ Ethernet interface

Select network by MAC Select network by Name

Distributed Clock

Cycletime 4000 μ s

Sync Offset 20 %

Options

Use LRW instead of LWR/LRD

Enable messages per task

Auto restart slaves

3.18.5 Ethernet speed

Since EtherCAT works in 100Mbps only, default setting of Ethernet speed is “Auto Negotiation”. Normally it should work, but if not, set “100Mbps/Full Duplex” in “Ethernet port Link speed / Duplex mode” and set “Yes” in “Change IP information” in [Configuration] tab in [Device] window. The PLC must be power-cycled to enable the parameter change.

Parameter	Type	Value
IP Address	STRING	'192.168.0.1'
Subnet Mask	STRING	'255.255.255.0'
Default Gateway	STRING	'0.0.0.0'
Ethernet port Link speed / Duplex mode	Enumeration of BYTE	100Mbps/Full Dup...
Change IP information	Enumeration of BYTE	Yes
Serial port mode	Enumeration of BYTE	IEC programming
Serial port type	Enumeration of BYTE	RS-232C
Serial port term. resistor (RS-422/485)	Enumeration of BYTE	No
Reset all outputs in STOP	Enumeration of BYTE	Yes
Stop switch definition	Enumeration of BYTE	Reset warm
External PHY Clock	Enumeration of BYTE	Yes

3.18.6 Cycle time of EtherCAT task

EtherCAT_Master task is automatically created when EtherCAT_Master is added besides Main Task. Double click on “EtherCAT_Master” or right click and choose “Edit Object” to open configuration window.

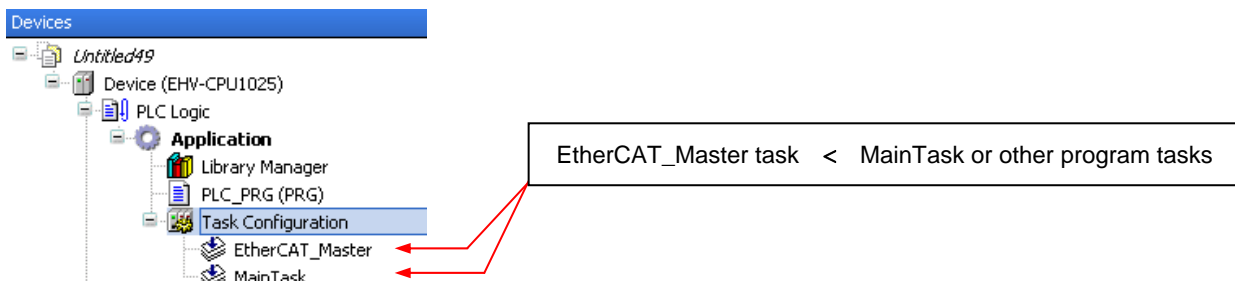

Since EHV+ series CPU handles all the tasks with a single microprocessor, the default value of “Interval” (4000 μ s) must be changed to bigger. If this value is too small to execute IEC program, 25 error (scan time error) will be detected. The minimum interval time depends on users’ program size and the number of I/O modules. In case of very small program with a few I/O modules, the recommend interval value would be 15ms or higher. If Profibus master or LINK module is used, it would be 50ms or more. In addition, this interval of EtherCAT_Master task must be smaller than the minimum interval time of other IEC program tasks.

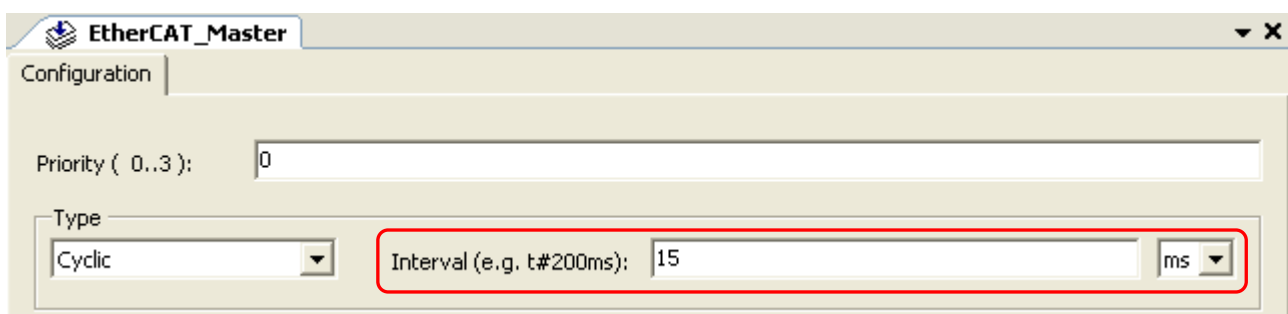

3.18.7 Programming

I/O addresses of slaves are displayed in “EtherCAT I/O Mapping” tab as below. Enter any variable names in this table and create your program as same way as other standard I/Os.

EL1002							
Slave Process Data EtherCAT I/O Mapping Status Information							
Channels							
Variable	Mapping	Channel	Address	Type	Default Value	Unit	Description
		Input	%IX0.0	BIT	0		Input
		Input	%IX0.1	BIT	0		Input

Note

When PLC is powered up with RUN switch position in RUN, I/O refresh of EtherCAT slaves starts about 1 second after I/O refresh of standard I/O started because of configuration between EtherCAT master and all slaves as below. If this delay is not accepted, use a special bit register “EtherCAT_Master.xConfigFinished”, which turns on when EtherCAT configuration is finished. The below codes are sample program in ST.

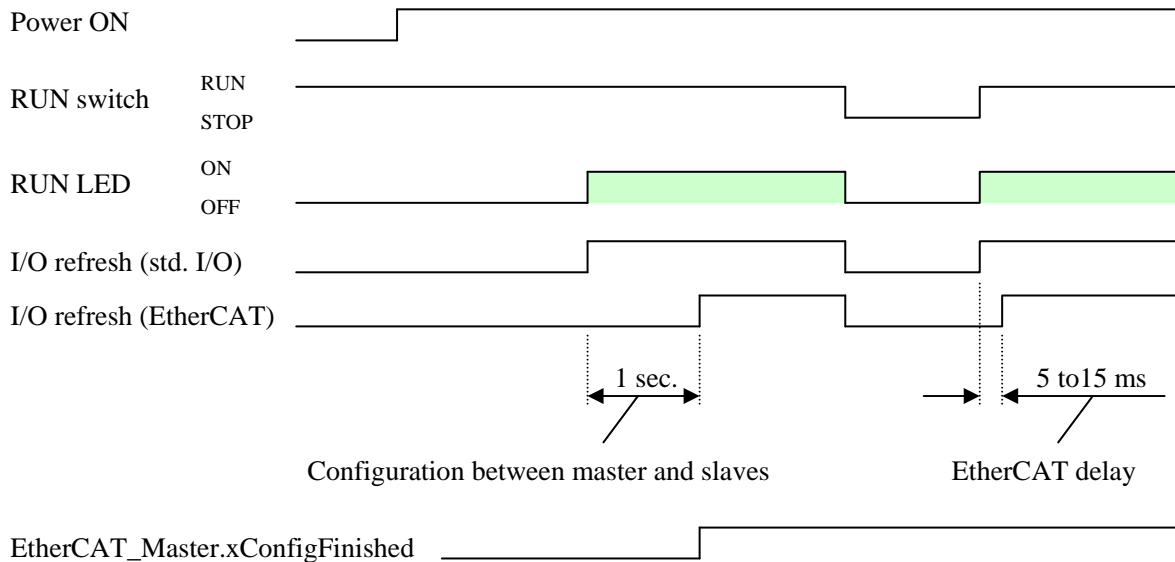

Sample program

```

IF EtherCAT_Master.xConfigFinished=FALSE THEN
  RETURN;
END_IF;

```

(Program under this code is not executed while EtherCAT_Master.xConfigFinished is FALSE.)

3.18.8 Wiring

(1) Cable

Use category 5 or higher STP (Shielded Twisted Pair) cable.

(2) Switch (Hub)

Standard switch (hub) is not allowed to use in EtherCAT network. If necessary, use a special device like EtherCAT hub (CU1128) sold by Beckhoff.

Note

Please note that using various Ethernet based communication (EtherCAT, Modbus-TCP, NVL, Gateway) at the same time will limit the communication performance.

3.18.9 Important restrictions

Byte-swapping

If slave units of 16/32/64-bit channels are used, be sure to configure “Enabled 2” in [Always update variables] in each slave mapping dialog, otherwise all I/O data are byte-swapped. This “Enabled 2” in [Always update variables] has been available since [CODESYS V3.5 SP5](#) or newer version.

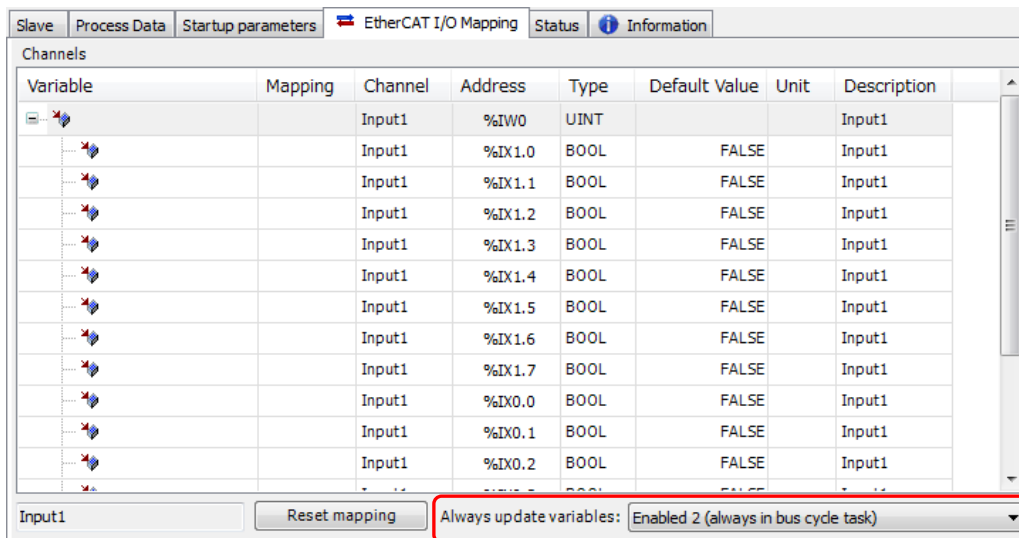

Even if “Enabled 2” is configured, it is not effective for ARRAY type variables. Please put a variable to each single channel instead of ARRAY.

	Do not enter here		_8_Analog_Input X	%IW14	ARRAY [0..7] OF UINT
	} Enter here		_8_Analog_Input X[0]	%IW14	UINT
			_8_Analog_Input X[1]	%IW15	UINT
			_8_Analog_Input X[2]	%IW16	UINT
			_8_Analog_Input X[3]	%IW17	UINT
			_8_Analog_Input X[4]	%IW18	UINT
			_8_Analog_Input X[5]	%IW19	UINT
			_8_Analog_Input X[6]	%IW20	UINT
			_8_Analog_Input X[7]	%IW21	UINT

This byte-swapping is a bug in IoDrvEtherCAT 3.5.5.0 library. To set “Enabled 2” is a temporary solution. It will be fixed in CODESYS V3.5 SP6, which is scheduled to release on Jan. 2015. Be sure to update IoDrvEtherCAT library to 3.5.6.0.

Auto restart slaves

Due to a bug in IoDrvEtherCAT library 3.5.5.0, “Auto restart slaves” does not work when power of slave unit is rebooted. If slave units are rebooted while the networking is running, restore the network by reset warm/cold or rebooting CPU module.

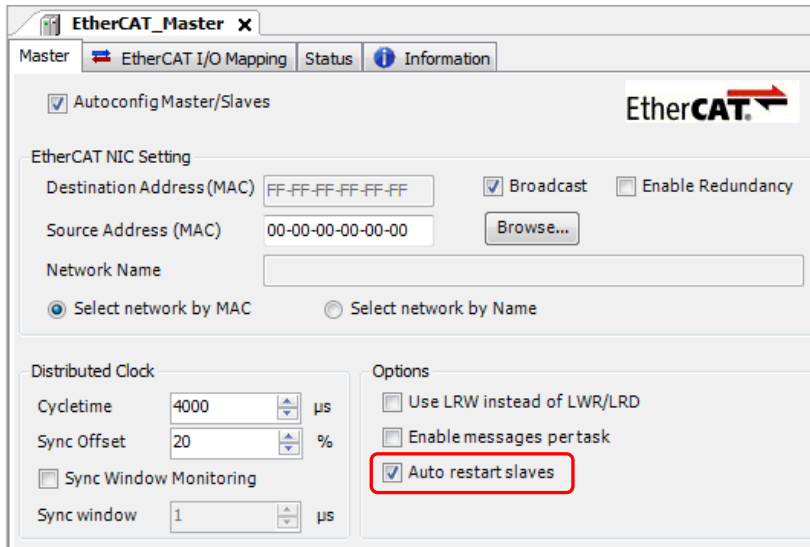

Besides this, “Auto restart slaves” may not always work when EtherCAT cable is plugged-out and plugged-in. This will be fixed in IoDrvEtherCAT library 3.5.7.0. If slaves do not restart, set operation mode manually with your program as below.

```
SlaveInstance.SetOpMode(ETC_SLAVE_STATE.ETC_SLAVE_PREOPERATIONAL)
SlaveInstance.SetOpMode(ETC_SLAVE_STATE.ETC_SLAVE_OPERATIONAL)
```

If current status is INIT, set PREOPERATIONAL at first, then set OPERATIONAL.
Current status can be seen by `SlaveInstance.wState`.

Scan for Devices without slaves

Due to a bug in IoDrvEtherCAT library 3.5.5.0, “Scan for Devices” does not work in two times in a row. If failed, perform Scan for Devices once again.

Scan for Devices with slaves configured

If right slave mapping information has been already downloaded to CPU module, “Scan for Devices” does not work. Since mapping information is already in CPU, it is not necessary to do “Scan for Devices” however, if it is necessary to configure slave units, configure manually with “Add Device”.

3.19 Libraries

3.19.1 How to install

In order to read/write EHV+ series CPU's specific information, following libraries are available. Add necessary CmpHIESLib by choosing "Add library" as shown below.

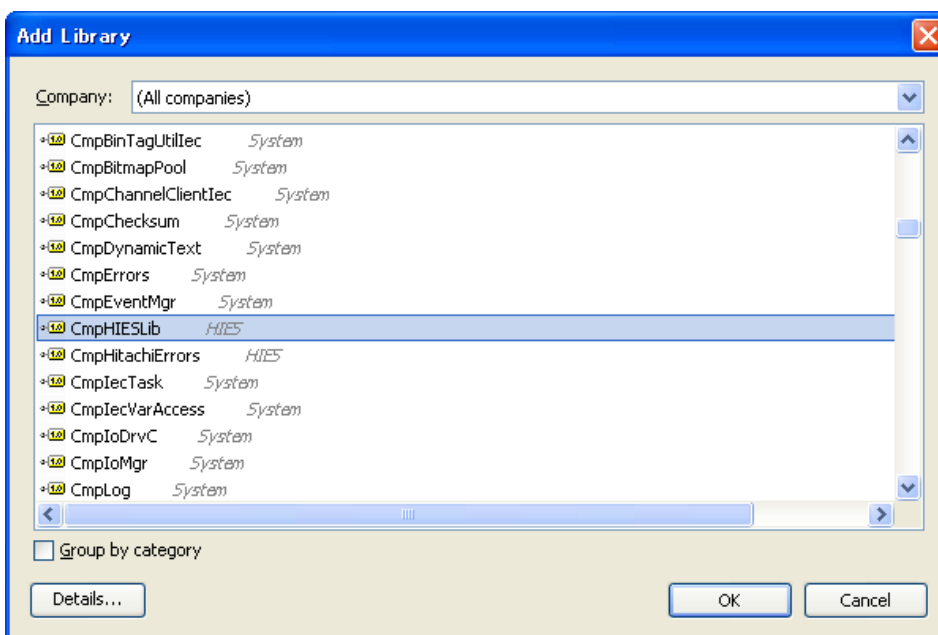
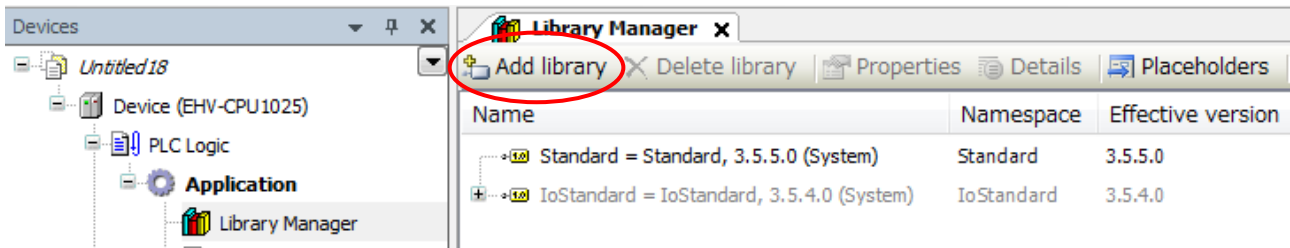

CmpHIESLib is Hitachi-IES's special library including;

- Libraries for counter module (EH-CU/CUE)
- Libraries for Link module (EH-LNK/OLNK)
- Library for Profibus master module (EH-RMP/2)

If these libraries are not found in the library list as above, install library by choosing [Tools]-[Install library...].



3.19.2 Realtime clock

Add “CAA Real Time Clock Extern” library by clicking “Add library” on Library manager.

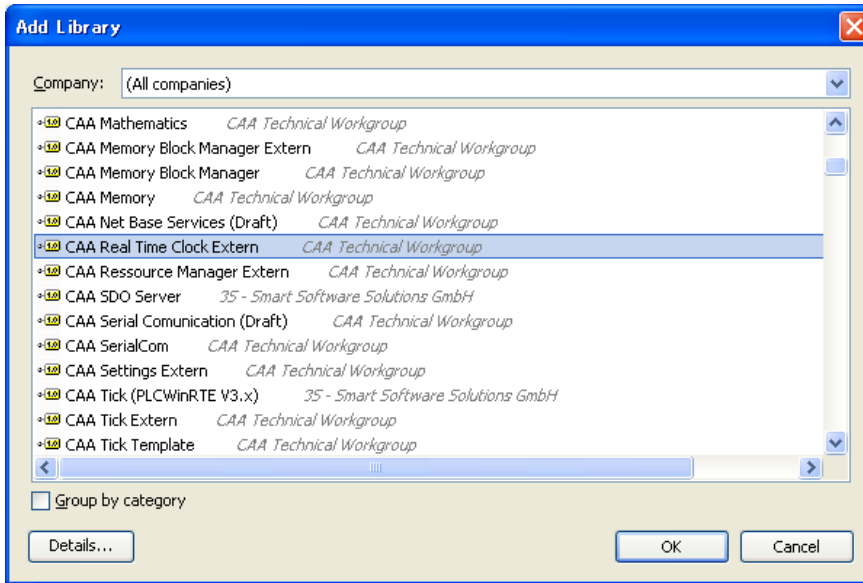

In the CAA Real Time Clock Extern libraries, GetDateAndTime and SetDateAndTime are supported. Be noted that the others are not supported.

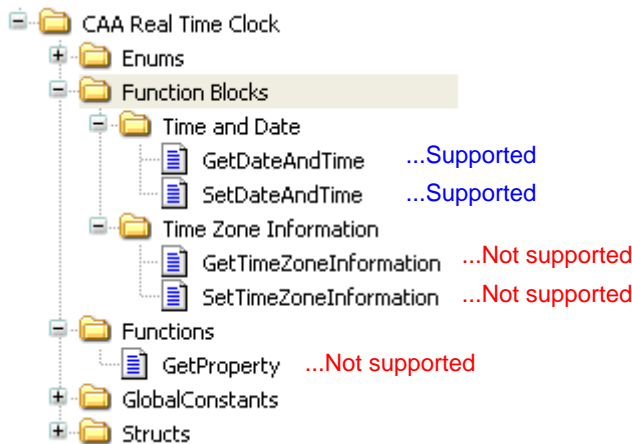

Following example is in FBD language. Choose [Insert Box] in [FBD/LD/IL] menu and GetDateAndTime or SetDateAndTime as shown below.

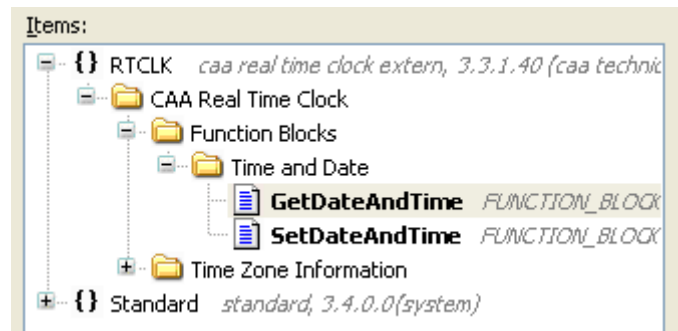
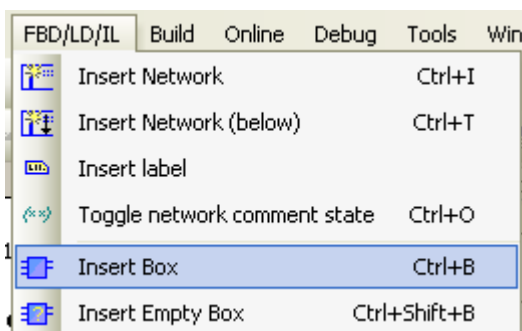

Declare instance of the function blocks and necessary variables as below.

```

1  PROGRAM PLC_PRG
2  VAR
3      SET_RTC_inst: SETDATEANDTIME;
4      SET_RTC: BOOL;
5      GET_RTC_inst: GETDATEANDTIME;
6      GET_RTC: BOOL;
7      Crnt_DateandTime: DATE_AND_TIME;
8  END_VAR

```

By rising edge of xExecute bit of SETDATEANDTIME, data in dtDateAndTime is written to the RTC device.

By rising edge of xExecute bit of GETDATEANDTIME, current date and time is read out to the variable connected to dtDateAndTime as shown below. When xExecute bit of GETDATEANDTIME is FALSE, dtDateAndTime is default value 1970-1-1-0:0:0.

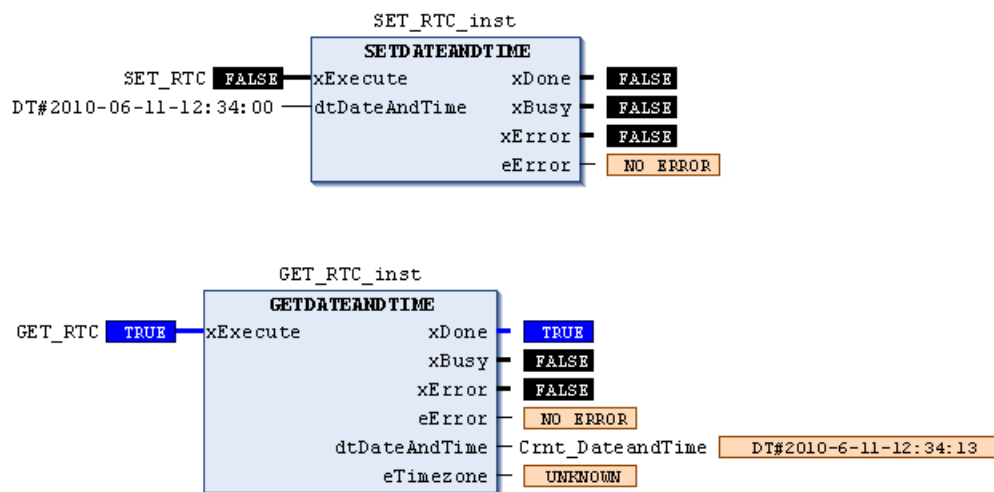

3.19.3 Serial communication

Add “SysCom” library by clicking “Add library” on Library manager. Instead of SysCom library, CAA SerialCom can be used, but a sample program of SysCom library is shown in this manual.

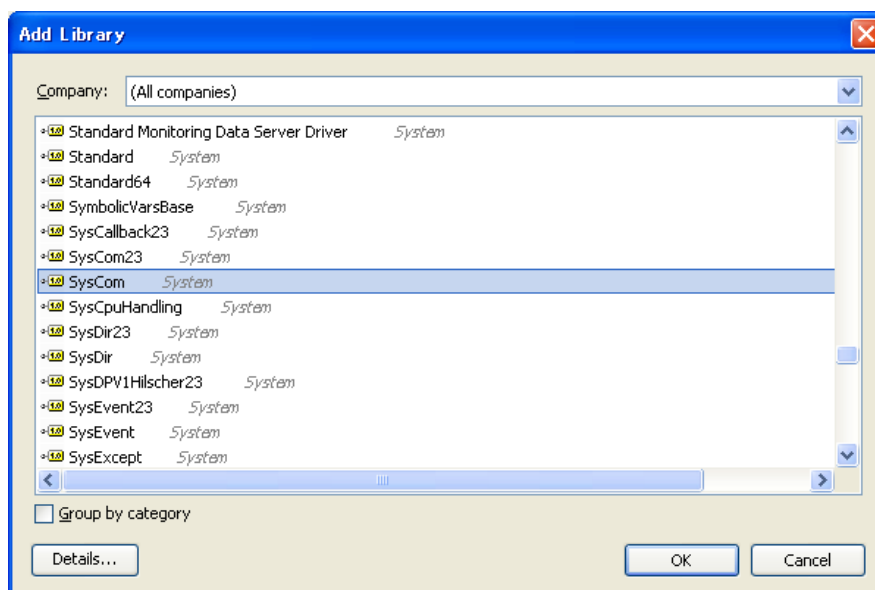

It is recommended to use ST language for serial communication settings since it is more flexible.

```

1  PROGRAM serial_sample2
2  VAR
3      COM_sample:COM_Settings;
4      COM_sampleEx:COM_SettingsEx;
5      message: STRING:='123';
6      Result: DWORD;
7      write_out: UDINT;
8      test: INT;
9  END_VAR
10
11  COM_sample.sPort:=COM_Ports.SYS_COMPORT1;           ...COM1
12  COM_sample.byParity:=COM_Parity.SYS_NOPARITY;       ...Non parity
13  COM_sample.byStopBits:=COM_StopBits.SYS_ONESTOPBIT; ...1 stop bit
14  COM_sample.ulBaudrate:=COM_Baudrate.SYS_BR_19200;   ...baudrate 19,200bps
15  COM_sample.ulBufferSize:=100;                       ...buffer size 100 bytes
16  COM_sample.ulTimeout:=10;                           ...Timeout 10ms
17  COM_sampleEx.byByteSize:=8;                         ...8 bit / frame
18
19  SysComOpen(SYS_COMPORT1, ADR(Result));
20
21  SysComSetSettings(SYS_COMPORT1, ADR(COM_sample), ADR(COM_sampleEx));
22
23  IF test= 1 THEN;
24  message := CONCAT('%02', message);                 ...Connect 02 + "123"
25  message := CONCAT(message, '%0d');                 ...Connect 02 "123" + 0d
26  write_out:=SysComWrite( SYS_COMPORT1, ADR(message), LEN(message), 1000, ADR(Result));
27  test:=0;
28  END_IF;

```

If the variable “test” is 1, then string data “02 31 32 33 0D” (STX 123 CR) will be sent out.

It is possible to write in FBD language as below, but it is necessary to set parameters in COM_Settings and COM_SettingsEx as same as above program line 1 to 7.

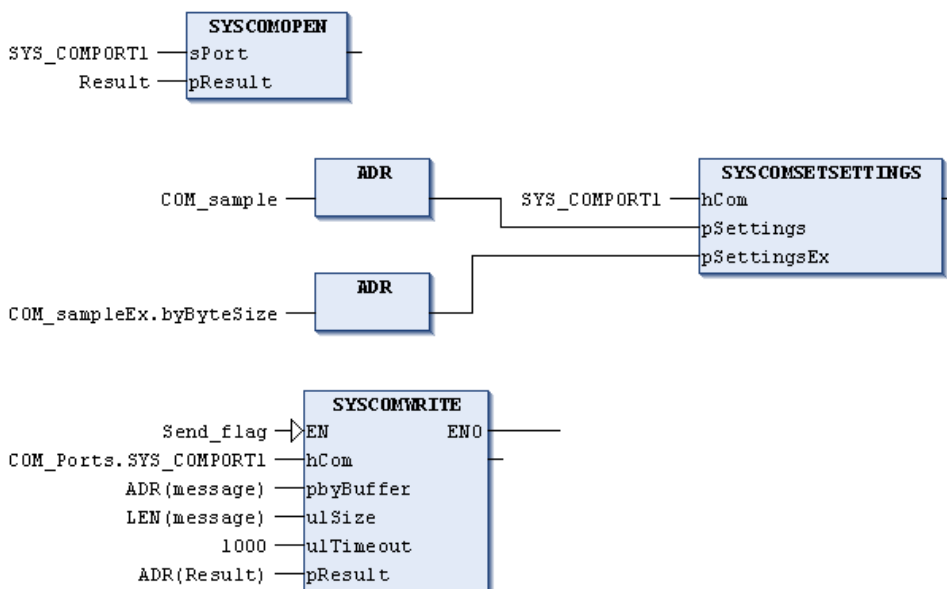

3.20 Troubleshooting

Error code



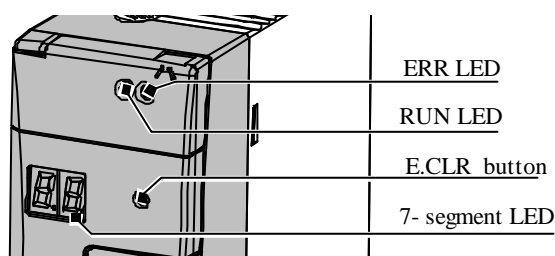











The CPU has 7-segment display and error LED to indicate an error code as listed below. If two or more errors are detected at the same time, smaller error code has higher priority to be displayed. If error is detected, read the description following countermeasures depending on error level.



Error code	Error level	Countermeasure
88, 11 to 1F	Serious error	Cycle power. If it does not solve, contact your local supplier.
20 to 31	Exception	Exception status is cleared only by Reset operation. Execute Reset cold/warm/origin by EHV-CODESYS
70 to 78	Warning	User program execution does not stop by warning. If you need to activate alarm or any action by warning, use CmpHitachi library. Press E.CLR button to clear error code.

Err. code	Error name [Detected when]	Description	PLC system	Applica-tion	ERR LED
88	Microprocessor failure [Power on]	Overflow of internal watchdog timer due to system program error.	Stop	Stop	
11	System program error (FLASH) [Power on]	Checksum value of system program (Runtime) in FLASH does not match the checksum calculated.	Stop	Stop	
12	System RAM failure [Power on]	Read/write check for system RAM has failed.	Stop	Stop	
13	Misalignment / Illegal instruction / Privileged instruction [Always]	Microprocessor has detected an exception processing in system program. (*1)	Stop	Stop	
15	Program RAM failure [Power on]	Read/write check for program RAM has failed.	Stop	Stop	
16	System program error (system RAM) [Always]	Checksum value of system RAM does not match the checksum calculated.	Stop	Stop	
18	MAC address error [Power on]	MAC address is missing or wrong value.	Stop	Stop	
19	Data memory failure [Power on]	Read/write check for data memory (RAM) has failed.	Stop	Stop	
1F	System program error (FLASH) [Always]	Checksum value of system program (reset process) in FLASH does not match the checksum calculated.	Stop	Stop	

: ON, : Blink, : OFF

Err. code	Error name [Detected when]	Description	PLC system	Applica- tion	ERR LED
20	Misalignment / Illegal instruction / Privileged instruction [Always]	Microprocessor has detected an exception processing in application.	Run	Stop	
21	Retain identity mismatch [Power on]	Retain data memory is undefined status due to battery empty. (*2)	Run	Stop	
23	Unresolved external references [Always]	Unresolved external references are detected.	Run	Stop	
24	Software watchdog of IEC task expired [Always]	Actual cycle time has exceeded watchdog time. Set longer watchdog time.	Run	Stop	
25	Processor load watchdog [Always]	Microprocessor load watchdog of all IEC task has been exceeded. Set longer interval time of task.	Run	Stop	
26	IEC task configuration failed [Always]	IEC task configuration has failed.	Run	Stop	
27	Division by zero [DIV executed]	The divisor of division command is 0 in IEC program.	Run	Stop	
31	Load boot project failed [Power on]	Checksum value of application (user program) in FLASH does not match the checksum calculated.	Run	Stop	
70	I/O configuration error [Always]	I/O configuration does not match with actual I/O modules.	Run	Run	
71	Battery error [Always]	Battery voltage is low or battery is disconnected.	Run	Run	Blink 
72	Special module failure [Always]	Hardware error is detected in special module or communication module.	Run	Run	
74	Comm. module configuration error [Download]	Configuration error is detected in communication module.	Run	Run	
77	FLASH writing failure [FLASH writing]	Failure has been detected in writing FLASH memory or the number of writing times has been exceeded.	Run	Run	
78	Parameters in FLASH check sum error [Power on]	Checksum value of parameters in FLASH (IP address, etc.) does not match the checksum calculated.	Run	Run	

: ON, : Blink, : OFF

CAUTION

If error cause is removed, error code remains except for error code 71 (battery error).

71 Error and ERR LED blinking automatically disappear if battery is replaced to new one.

(*1) 13 Error

If error code 13 is displayed, it is not possible to communicate with EHV-CODESYS because the system program or boot project is failure. If cycling power does not solve the problem, boot project could be failure. In this case, try to delete boot project as follows.

Note: This function is supported by ROM VER.3.4.4.3 or newer.

< How to delete boot project >

- (1) Remove power from the PLC
- (2) Toggle the RUN/STOP switch to STOP position.
- (3) Supply power to the PLC with E.CLR button pressed until “SP” is displayed in the 7-segment LED.



- (4) Toggle the RUN/STOP switch to RUN position. It takes a few seconds to delete boot project. Then “Fn” is displayed in the 7-segment LED.



- (5) Reboot the PLC and check if the error code disappears. (Even if the RUN/STOP switch is in RUN position and application program in SRAM is retained by battery, CPU does not start because there is no boot project.)
- (6) Login and create boot project to restore your system.

(*2) 21 Error



(1) If boot application and application are different, 21 error appears at power up. The reason is as follows. Each application has GUID (globally unique identifier) and this GUID is changed if the application is recompiled (Clean & Build). After downloading of application, this GUID is saved in retain memory. Boot application has GUID also. At every power up, the both GUID are compared and if they are different, 21 error appears.

(2) Due to above mentioned GUID mechanism, when boot project is loaded and battery is empty or disconnected at that time, CPU does not start with 21 error. For this reason, be sure to install a battery even if you don't use retain data or real time clock. If you do not want to use a battery or if application must start regardless of battery full or empty, 21 error can be disabled as follows.

Note

Above description is applied to CPU ROM VER. 3.4.x.x. The behavior had been changed as follows since CPU ROM VER. 3.5.x.x. If retain or persistent variable is not used, CPU starts even if battery is empty or missing.

How to edit config.cfg file

1. Open “Device” and click “Files” tab as below.
2. After establishing communication (set active path), click update icon  in the right field.
3. The left field is inside of your PC. Specify a folder to upload config file.
4. Choose config.cfg and click  button.

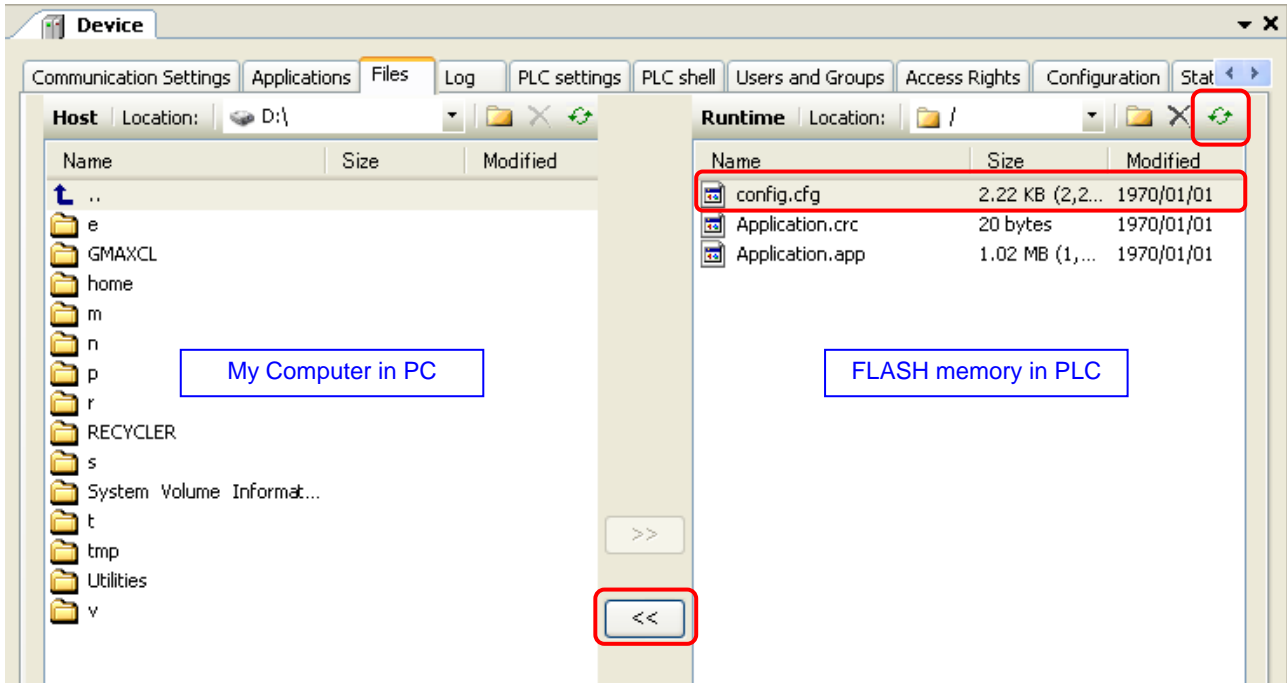

5. Go to specified folder at #3 and open the config.cfg with text editor.
6. In this file, there is a description shown below. Change “1” to “0” and save as same name.

```
[CmpApp]
Bootproject.RetainMismatch.Exception=1
```



```
Bootproject.RetainMismatch.Exception=0
```





7. Click the updated config.cfg in the left field and click  button.
8. Now config.cfg in CPU is updated.

Note

Config.cfg file has important parameters for CPU operation. Do not modify any other part in this file than described in this manual. Wrong modification could result in serious failure of CPU.

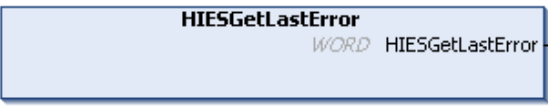
Error libraries

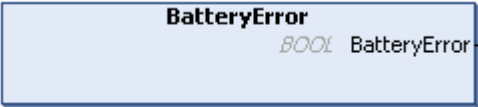
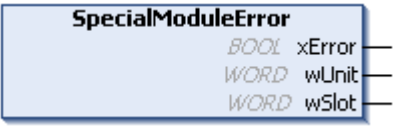
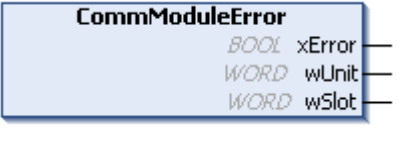
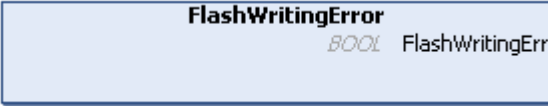
As for warnings (error code 70 to 78), special libraries called “CmpHitachiErrors” are available as below. Use them in your application program if necessary. If it is not registered in your library repository, install CmpHitachiErrors.library by choosing [Tools]-[Install library...].

Error code	Libraries (CmpHitachiErrors.library)	Input	Output
all		-	Last detected error code (WORD)
all		Execution bit to clear error code (BOOL)	Result (BOOL)
70		-	70 Error bit (BOOL) Unit number (WORD) Slot number (WORD)
71		-	71 Error bit (BOOL)
72		-	72 Error bit (BOOL) Unit number (WORD) Slot number (WORD)
74		-	74 Error bit (BOOL) Unit number (WORD) Slot number (WORD)
77		-	77 Error bit (BOOL)
78		-	78 Error bit (BOOL)

3.21 Version

Firmware version (Target-Version) of your CPU is monitored in communication settings of Device as below.

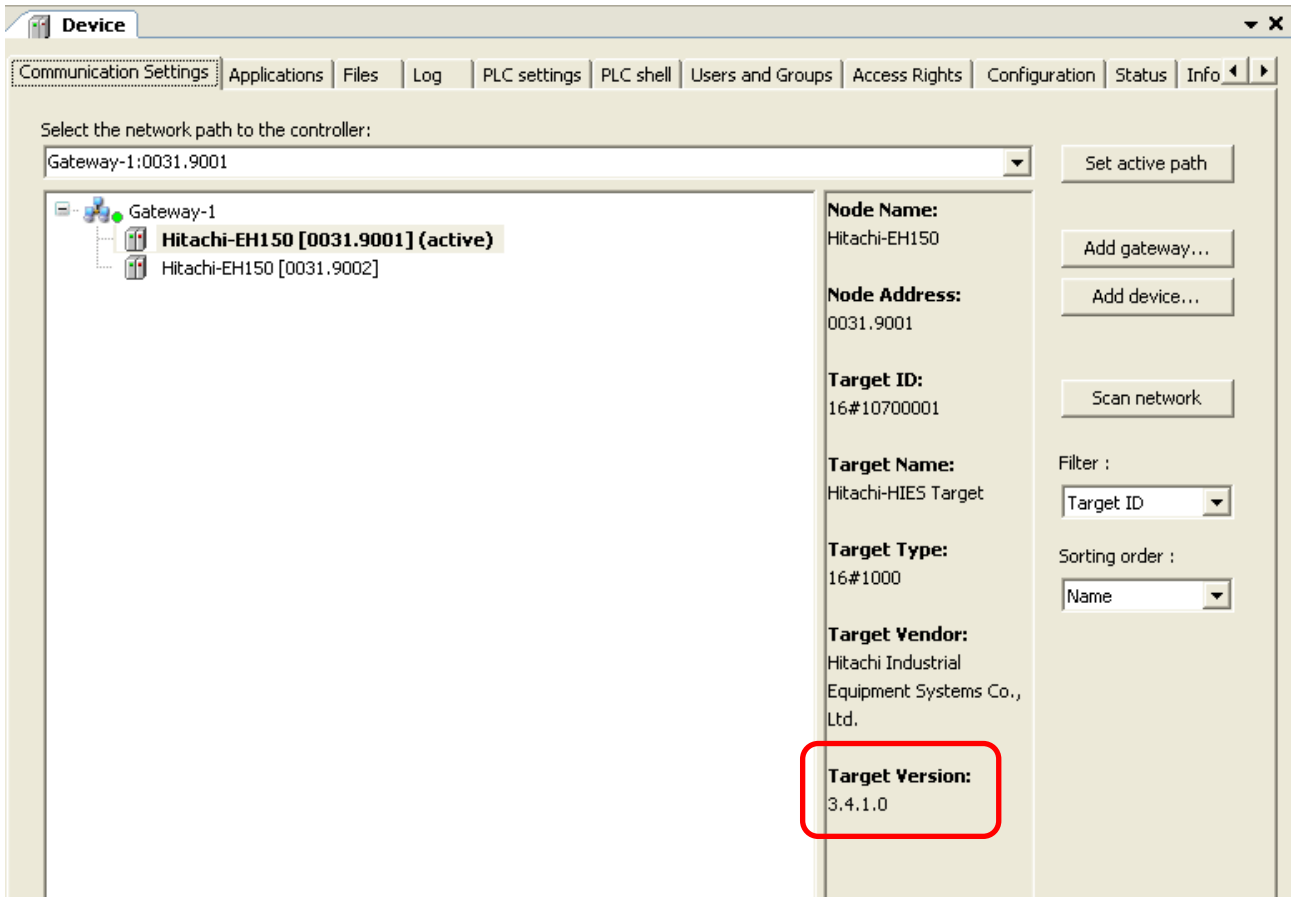

3.22 Notes for version compatibility

3.22.1 Device version

Since several new features are related to not only CPU but also CODESYS, be sure to use correct version of CODESYS/EHV-CODESYS, CPU and device as follows, otherwise login fails with an error message. Refer to the section 3.3.4 Update Device for the device version.

Device version is not CPU's ROM version, but the version written in devdesc.xml file, which can be seen in [Device]-[Information].

EHV-CODESYS / 3S CODESYS	ROM version of CPU	Device version	Remarks
V3.4 SP1 or SP4	3.4.1.3 or older	3.4.1.1 to 2	
	3.4.4.0 to 3.4.4.3	3.4.4.0	
	3.4.4.4 to 3.4.4.5	3.4.4.1 to 32	
V3.5 SP3 Patch6	3.4.4.4 or 3.4.4.5	3.4.4.1 to 32	
V3.5 SP4	3.5.4.10	3.5.4.10	EtherCAT function is limited. Refer to 3.18.9.
V3.5 SP5 or newer	3.5.4.10	3.5.4.10	
	3.5.4.11	3.5.4.11	

* If CPU ROM VER.3.4.4.3 or older needs to be used with CODESYS/EHV-CODESYS V3.5, please contact your local supplier to update the firmware.

3.22.2 CPU ROM VER.3.4.1.x with EHV-CoDeSys V3.4 SP4

CPU V3.4.1.3 or older works with EHV-CoDeSys V3.4 SP4 however, the function "Scan for Devices" is not working properly. Be sure to use newer device description file V3.4.1.2.

EHV-CODESYS	ROM version of CPU	Device version	Availability
V3.4 SP4	3.4.1.3 or older	3.4.1.1	Scan for devices is not working
	3.4.1.3 or older	3.4.1.2	OK

3.22.3 Supported Modbus devices

Although Modbus devices version 3.5.x.x are available in EHV-CODESYS V3.5 SP3 Patch6, CPU ROM VER.3.4.x.x supports only Modbus device version 3.4.x.x as listed below. Be sure to choose proper Modbus device.

Modbus-TCP Master

Device	Version
Modbus TCP Master	3.4.3.0
Modbus TCP Slave	3.4.0.0

Modbus-TCP Slave

Device	Version
ModbusTCP Slave Device	3.4.3.0

Modbus-RTU Master

(For CPU and EH-SIO both)

Device	Version
Modbus Master, COM Port	3.4.3.2
Modbus Slave, COM Port	3.4.0.0

[How to display Modbus device version 3.4.x.x]

Click “Display all versions (for experts only)” at “Add Device” window and choose device version 3.4.x.x

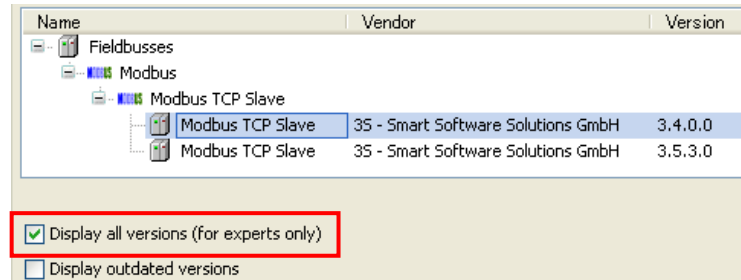

3.22.4 CPU ROM VER.3.5.4.x

In principle, any older version of CODESYS can work with new CPU, but it is strongly recommended to use CODESYS V3.5 SP4 or newer for CPU ROM VER.3.5.4.x because right library files may be missing in older CODESYS.

If EtherCAT master function is used, be sure to use CODESYS V3.5 SP5 or newer for CPU V3.5, otherwise I/O data of EtherCAT slaves are byte-swapped. Please refer to 3.18.9 Important restrictions for further information.

Even if EtherCAT master function is not used, it is recommended to use CODESYS V3.5 SP5 also because this version has been mainly used for tests of CPU V3.5 in Hitachi-IES. (The combination of Runtime V3.5.4.x and CODESYS V3.5 SP4 has been carefully tested by 3S and the upper compatibility is guaranteed by 3S.)

In order to improve stability and reliability of TCP/UDP communication, new TCP stack (middleware) has been used since CPU ROM VER.3.5.4.10 and the priorities of several tasks has been modified accordingly. For this reason, the maximum performance of IEC task or communication task (networks variables, OPC access, Modbus-TCP, etc.) are not exactly the same between V3.4 and V3.5 CPU. Although task priorities have been carefully designed to keep upper compatibilities, please be noted that processing time of each task could be slightly different especially in case several tasks are executed in parallel.

Since TCP stack has been updated, CAA NetBaseServices (library for data communication) has been supported since CPU ROM VER.3.5.4.10.

Chapter 4 Installation

For use in safety, avoid installing the PLC in the following locations.

- Excessive dusts, salty air, and/or conductive materials (iron powder, etc.)
- Direct sunlight
- Temperature less than 0°C or more than 55°C
- Dew condensation
- Humidity less than 5% or more than 95%
- Direct vibration and/or impact to the unit
- Corrosive, explosive and/or combustible gasses
- Water, chemicals and/or oil splashing on the PLC
- Close to noise emission devices

4.1 Installation

(1) Installing location and environment

- (a) Install the PLC in Use the environment specified in the “2.1 General Specifications”.
- (b) Mount the PLC onto the metal plate.
- (c) Install the PLC in a suitable enclosure such as a cabinet which opens with a key, tool, etc.

(2) Installation of a base unit

(a) Precaution when installing the base unit

- 1] Fix the base unit securely with screws in 4 places (M4, length 20mm (0.79in.) or longer) or DIN rail.
- 2] In order to keep within allowable ambient temperature range,
 - a) Ensure sufficient space for air circulation. (50mm (1.97in.) or more at top and bottom, 10mm (0.39in.) or more at right and left)
 - b) Do not install close to equipment that generates a lot of heat (heater, transformer, large-capacity resistance, etc.).
 - c) If ambient temperature is more than 55°C, install a fan or a cooler so that the ambient temperature becomes below 55°C.
- 3] Do not install inside a cabinet with high-voltage equipments installed.
- 4] Install 200mm (7.87in.) or more away from high-voltage wires or power wires.
- 5] Do not install the PLC upside down in vertical nor in horizontal.

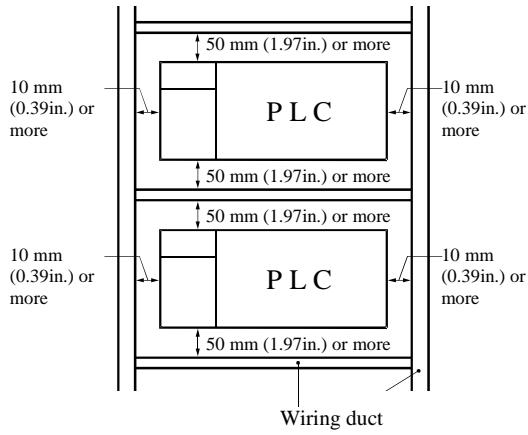

Figure 4.1-1 Amount of installation

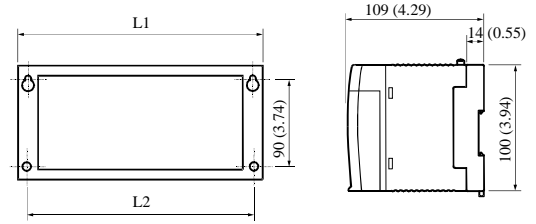

Figure 4.1-2 External dimensions

Dimensional table

Base	L1 (External dimensions)	L2 (Mounted dimensions)
3 slots	222.5 (8.76)	207 (8.15)
5 slots	282.5 (11.2)	267 (10.51)
6 slots	312.5 (12.30)	297 (11.69)
8 slots	372.5 (14.67)	357 (14.06)
11 slots	462.5 (18.21)	447 (17.6)

Unit: mm (in.)

(b) Mounting to a DIN rail

Attaching to a DIN rail

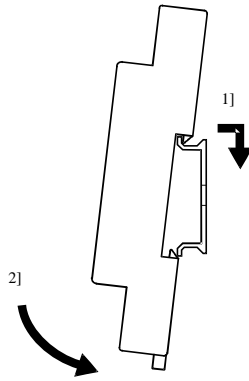

- 1] Hook the base unit to a DIN rail as shown left.
- 2] Press the base unit into the DIN rail until it clicks.

Note: Make sure the base unit is securely fixed after installation.

Fixing the unit

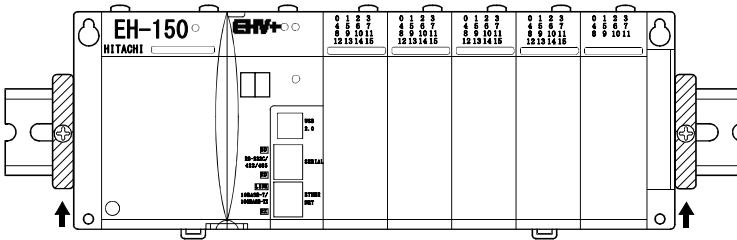

Install DIN rail clamps from both sides. (The unit could slide without clamps.)

Removing the unit from the DIN rail

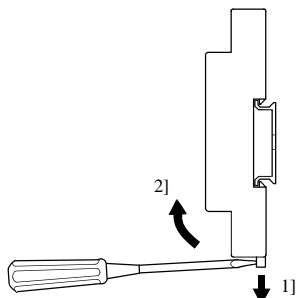

- 1] Pull down the retaining clip on the bottom of the base unit.
- 2] Pull the unit away from the DIN rail.

4.2 Mounting Module

(1) Mounting

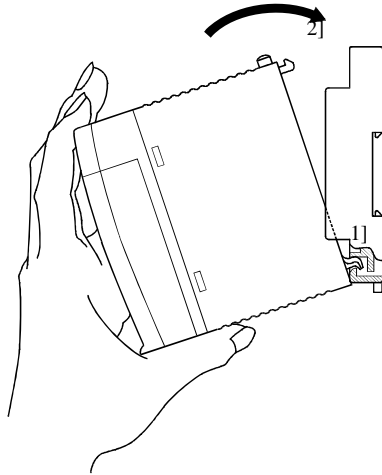

- 1] Hook the lower part of the module to the hole in the base.
- 2] Press in the upper side of the module until it clicks.

Note 1: Make sure the module is mounted securely.
 Note 2: Slot position of power supply module is fixed as 1st slot of base unit.

Note 3: Slot position of CPU module is fixed as 2nd slot of base unit.

Modules can be fixed firmly by $M4 \times 10\text{mm}$ screws.

(2) Removing

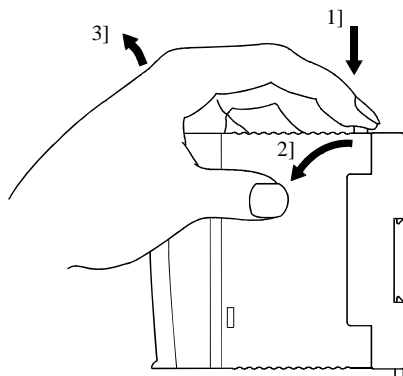

- 1] Press the lock button.
- 2] With the lock button pressed, pull the top of the module.
- 3] Pull the unit away from the base unit.

Note: Press the both lock buttons for a power supply module.

4.3 Wiring

(1) Separation of power system

Several different power sources are used with PLC, such as main power of PLC, power for I/O signal and power for external devices. These power sources should be separated as much as possible.

If these power sources come from one power source, install transformers or noise filters to separate those power lines as much as possible.

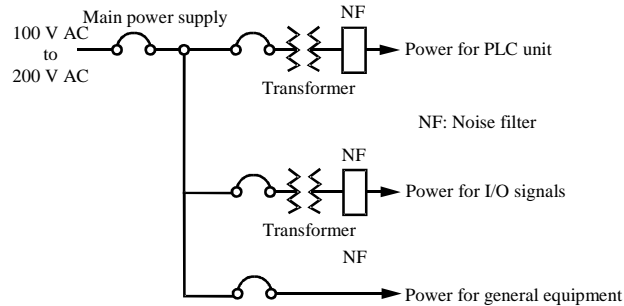

Figure 4.3-1 Example of power system diagram

(2) Fail safe

1] Construct an interlock circuit outside the PLC.

When the PLC power supply is turned ON/OFF, the lag time and the difference in the startup time between the PLC unit power and the external power (particular DC power supply) for the PLC I/O module signals may temporarily cause the I/O not to operate normally.

Do not control the power for the EH-YR12 relays to have it perform an interlock with the external load, etc. The relay may turn on even when the power has not been supplied by an aluminum electrolytic capacitor inside the module to drive the relay.

Also, it is conceivable that a fault in the external power and a failure in the PLC unit lead to abnormal actions. To prevent such actions from causing abnormal operation the entire system, and from a point of view of creating a fail safe mechanism, construct circuit such as an emergency stop circuit, the protect circuit, and the interlock circuit, for the sections that lead to a mechanical breakdown and accident from abnormal actions outside the PLC.

2] Install a lightning arrester

To prevent damage to equipment as a result of being struck by lightning, we recommend setting up a lightning arrester for each PLC power supply circuit.

The power supply module detects power failures from a voltage drop of the internal 5 V DC power supply. For this reason, the load in the 5 V DC power of the unit is light, the 5 V DC is retained for a long time and operations may continue for more than 100ms. Therefore, when using the AC input module, an OFF delay timer for coordinating with the internal 5 V DC is needed because the AC input signal turns off more quickly than the internal 5 V DC.

(3) Wiring to the power module

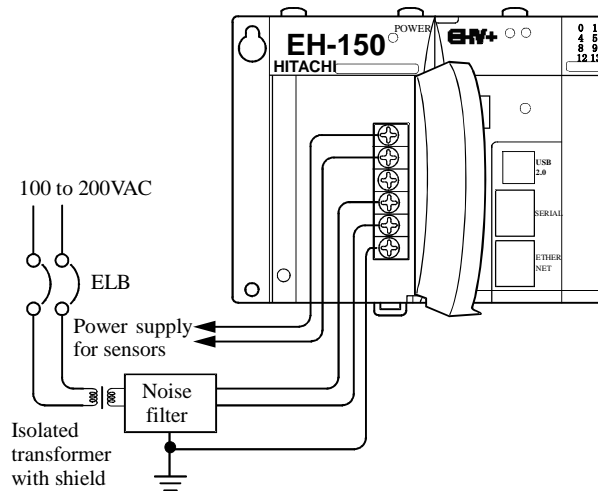
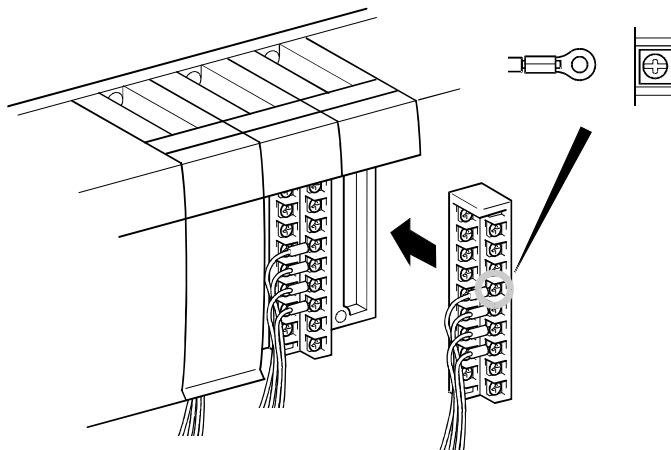

Figure 4.3-2 Wiring power diagram

- (a) For power supply wiring, use a cable of 2 mm^2 (0.0031 in.^2) or more to prevent a voltage drop from occurring.
- (b) The function ground terminal (FE terminal) should use a cable of 2 mm^2 (0.0031 in.^2) or more and Class D grounding ($100 \ \Omega$ or less). The appropriate distance for ground cable is within 20m (65.62ft.).
 - 1] Shared with instrumentation panel, relay panel grounding.
 - 2] Avoid joint grounding with equipment that can generate noise such as high-frequency heating furnace, large power panel (several kW or more), thyristor exchanger, electric welders, etc.
 - 3] Be sure to connect a noise filter (NF) to the power cable.
- (c) The terminal screw size is M3. Recommended torque is from 0.49 to 0.78 $\text{N}\cdot\text{m}$ (4.3 to 6.9 in.-lbs).
- (d) Use the same power supply system for the basic and expansion units.

(4) Wiring cable for I/O signals



The terminal screw size is M3.

Recommended torque is from 0.71 to 1.02 $\text{N}\cdot\text{m}$ (6.3 to 9 in.-lbs).

Use a crimp terminal with an outer diameter of 6mm (0.24in.) or less when using it.

Use only up to 2 crimp terminals in the same terminal. Avoid clamping down more than 3 at the same time.

The terminal block supports 0.3 to 2 mm^2 (AWG22 to 14). However, recommended cable is from 0.5 to 0.75 mm^2 (AWG20 to 18). If 2 crimping terminals are connected to one terminal screw, use 0.5 mm^2 (AWG20) cable.

Note: Use shielded cable for the relay output module when corresponding to CE marking EMC command is necessary.

Attaching the terminal block

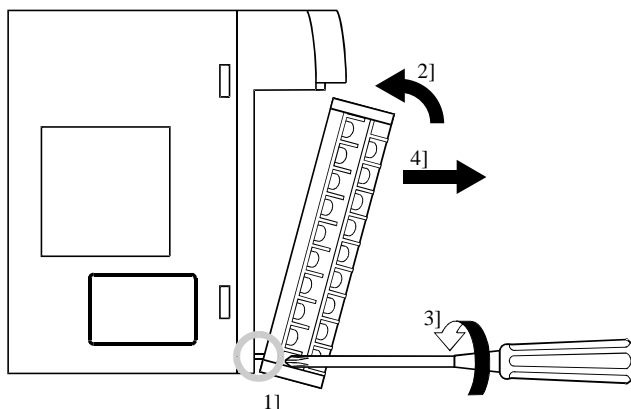

- 1] Align the tip of a terminal block mounting screw to the screw section of the I/O cover insertion fittings.

- 2] Push in the top of the terminal block until the I/O cover claw section locks with a click.

- 3] Tighten terminal block mounting screws while holding down the upper part of the terminal block.

- 4] Pull on the top of the terminal block to make sure that it is locked and cannot come out.

Note: Always reinstall it following the instructions above if the terminal block is removed.

(5) Input wiring for the input module

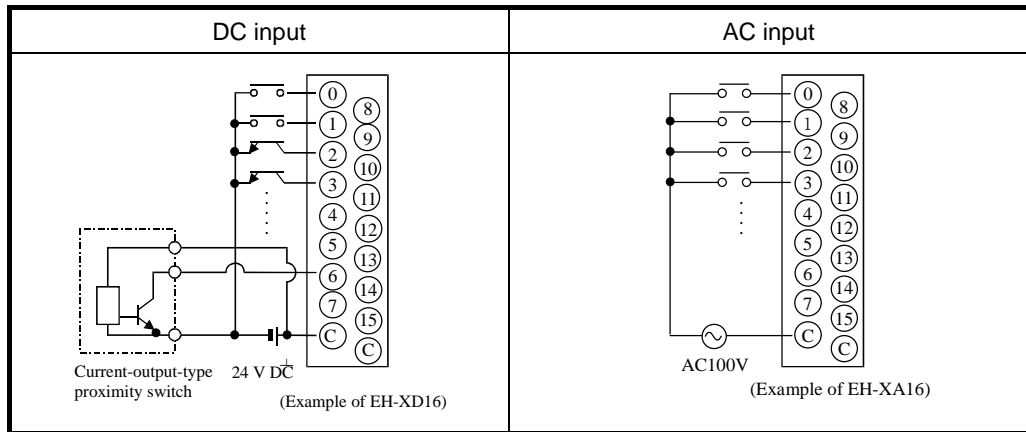
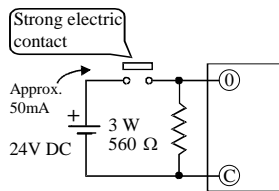

Figure 4.3-3 Input wiring

(a) DC input module

- 1] When all input terminal (X0, X1, ...) and the common terminal (C) are loaded with 24 V DC, the input changes to ON, and approximately 6.9 mA current in case of EH-XD8 and approximately 4 mA current in case of EH-XD16, flow to the external input contacts.
- 2] For sensors such as a proximity switch and photoelectric switch, current-output-type (transistor open collector) can be directly connected. For voltage-output-type sensors, connect them to the input terminal after first going through the transistor.
- 3] Measures to prevent faulty contact in a strong electric contact



The current that flows to a contact when external contacts are closed is approximately 6.9mA for the EH-XD8, and approximately 6.9mA for EH-XD16. If the use of a strong electric contact cannot be avoided, add resistance as shown in the diagram at left and supply sufficient current to the contact to prevent a faulty contact.

- 4] Limit the wiring length within 30 m (98.43ft.).

(b) Wiring for 32/64-point input module (Based on CE marking)

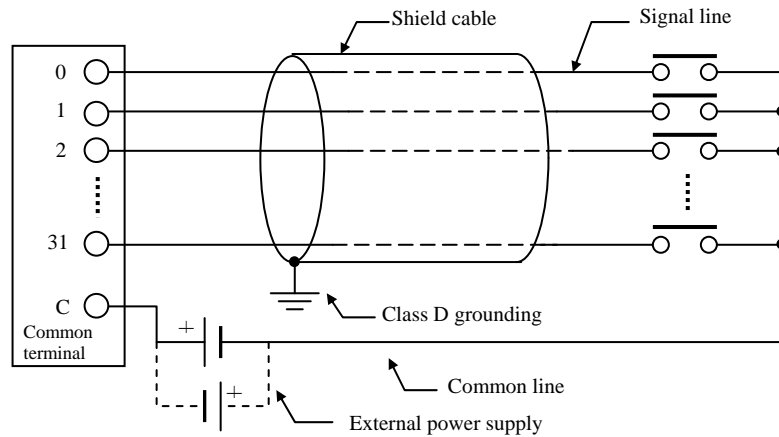

Note:

- 1] Wire only the signal line through the shield cable, and provide class D grounding on the shield cable side.
- 2] Do not wire the common line or S terminal line through the shield cable. Be sure to wire them independently and separately from the power line, I/O lines or power supply line.
- 3] The supply line to the external power supply should be wired as close as possible to the common terminal of the output module.

(c) AC input module

When using the AC input module, if the wiring route gets longer, a phenomenon that voltage is generated on the input terminal though there is no signal actually because the leak current flows by the stray capacity between wirings may occur.

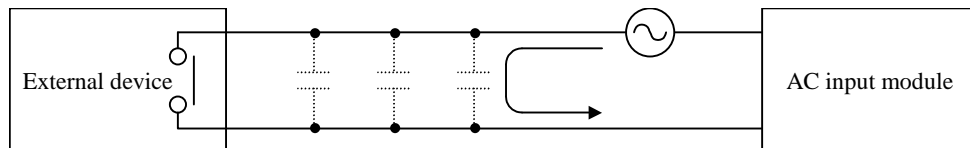

There are the following two methods 1] and 2] as measures. Please limit the voltage caused by the electrostatic combination on the input terminal to half of the maximum OFF voltage of the input module.

- 1] Lower impedance of the input module by connecting the dummy resistance with the input terminal in parallel.
- 2] Connect the external power supply to the external device side.

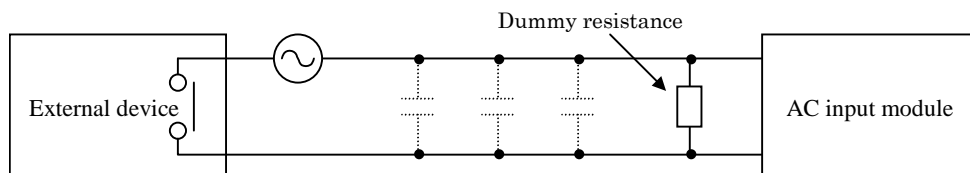

(6) Output wiring for the output module

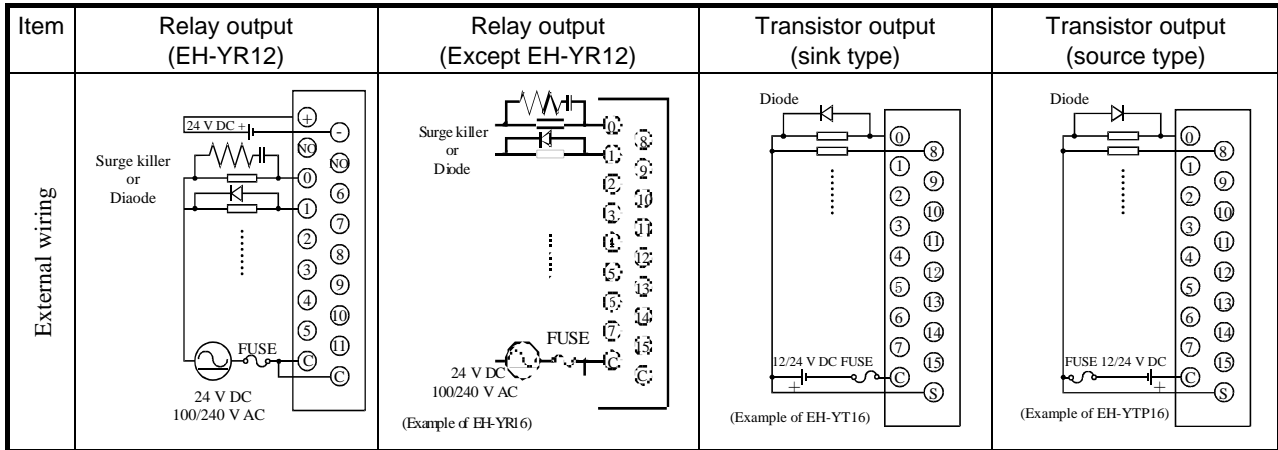
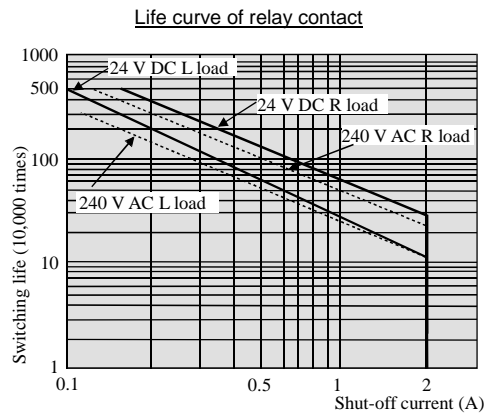

Figure 4.3-4 Output wiring

(a) Wiring for the relay output module

1] Life of relay contact



Life of the contact is also in squared reverse proportion to the current, so be aware that interrupting rush current or directly driving the capacitor load will drastically reduce the life of the relay. When switching is done with high frequency, use a transistor output module.

2] Surge killer

For inductive load, connect a surge killer (capacitor 0.1 μ F, + resistance of around 100 Ω) in parallel to the load. Also, for DC load, connect a flywheel diode.

3] Fuse

A fuse is not built in this module. Install a 6A fuse in the common to prevent the external wiring from burning out.

4] Power supply for driving the relay

If a 24 V DC power supply is connected to drive the relay, take care with respect to the polarity when connecting. There is a risk that the internal circuit will be damaged if the wiring is done incorrectly. Also, do not perform an interlock, etc. to the external load with the power supply for driving the relay.

(b) Wiring for the transistor output module

1] Flywheel diode

For inductive load, connect a flywheel diode in parallel.

2] S and C terminals

Always connect an S terminal and C (common) terminal. If the module is used without connecting these terminals, the internal flywheel diode does not function and there is a risk that the module will malfunction or breakdown.

3] Fuse

A fuse is inserted in the common to prevent the external wiring from burning out, but this does not protect transistor elements. Therefore, note that these elements are destroyed when the external load is short-circuited. Please contact us for repair if the external load short-circuits.

Also, if the fuse blows, there will be no output even if the LED lights up. (The fuse out lamp for the module at this time as well as a CPU module error will not be displayed.)

Note: If the fuse is melted or blown, do not supply power to the module after changing the fuse without eliminating the source of the problem. Damage escalation, smoke, etc., may otherwise result.

(c) Wiring for the 32/64-point output module (Based on CE marking)

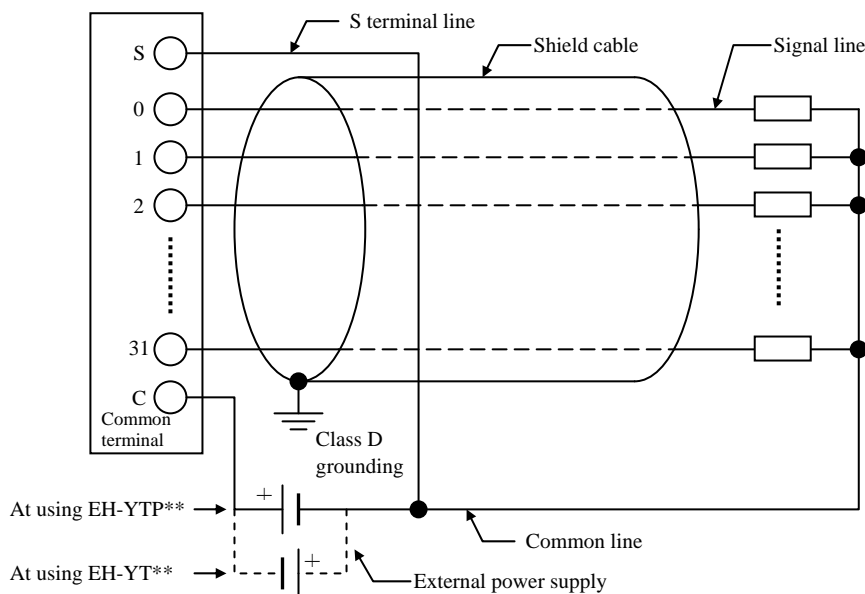

Note:

- 1] Wire only the signal line through the shield cable and provide class D grounding on the shield cable side.
- 2] Do not wire the common line or S terminal line through the shield cable. Be sure to wire them independently and separately from the power line, I/O lines or power supply line.
- 3] The supply line to the external power supply should be wired as close as possible to the common terminal of the output module.

(7) I/O wiring for the analog module

- Do not apply excess voltage to the analog input module beyond the rated input voltage. Similarly, do not subject the module to current that exceeds the rated input current. Connecting the analog input module to a power supply other than the specified types may cause damage to the product or burning of its internal components.
- For unused channels of the analog input module, short the input terminals before use.
- For unused channels of the analog output module (unused current output channel, 2 to 3 channels), short the outputs before use.
- When wiring the external lines of the analog module, route them through the shield cables while separating them from other power lines or signal lines subject to differential voltage. Shield cables must be grounded on one side. However, whether it is more effective to ground on one side or leave both sides open, depends on the noise environment condition in the actual use. Provide appropriate grounding based on the noise environment.
- Use separate piping for the AC power supply line and the signal/data lines.
- Wire the signal lines and data lines as close as possible to the grounded surface of the cabinet or a metal bar.

(8) Wiring to the module terminal

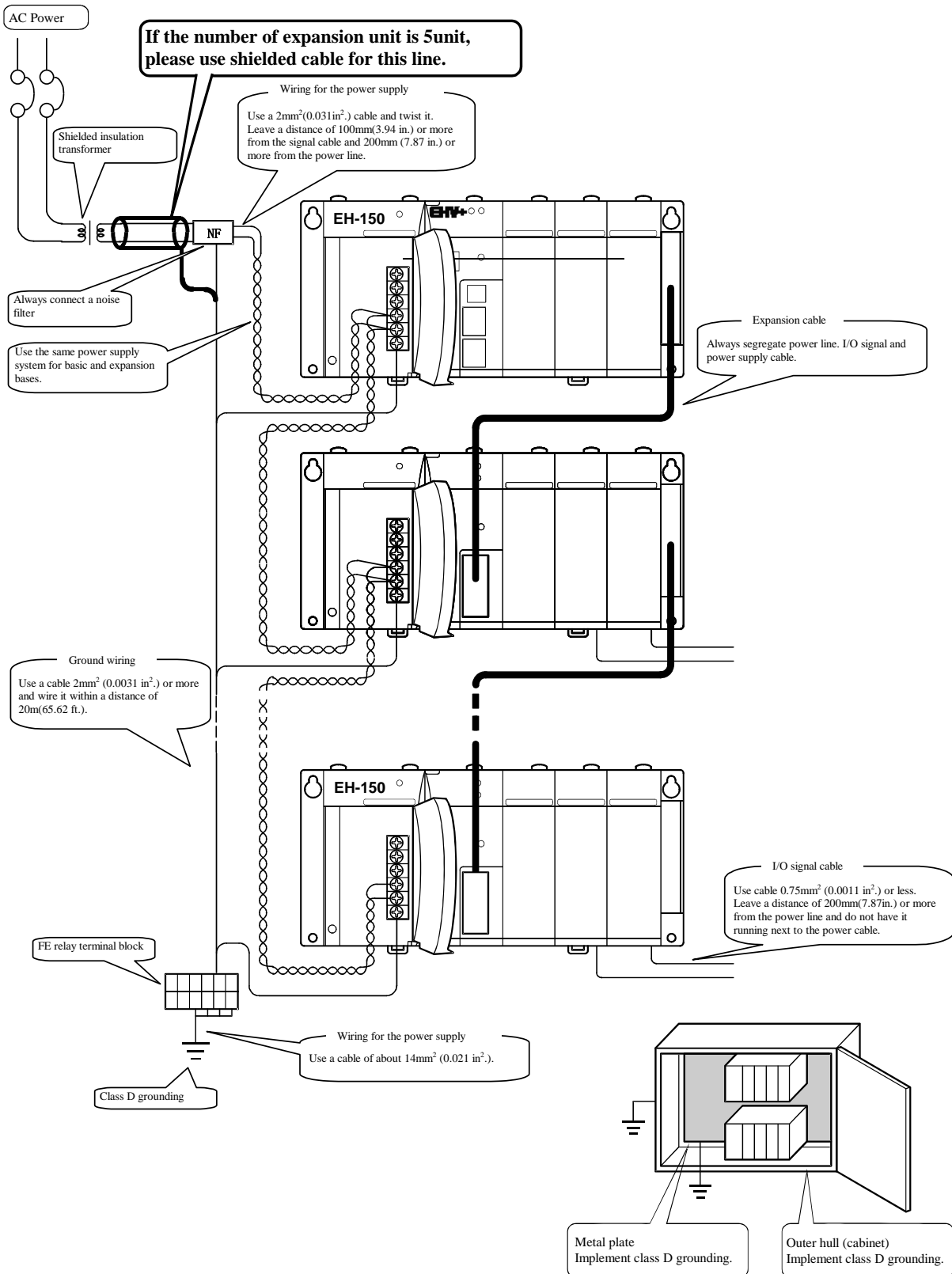

Figure 4.3-5 Example of wiring

MEMO

Chapter 5 Maintenance

In order to use the PLC in the best condition and maintain the system to operate properly, it is necessary to conduct daily and periodic inspections.

5.1 Daily and Periodic Inspection

(1) Daily inspection

Verify the following items while the system is running.

Table 5.1-1 Items for daily inspection

Item	LED display	Inspection method	Normal status	Main cause of error
Power module display	POW	Visual check	ON	Power supply error, etc.
CPU module display	RUN	Visual check	ON (Running)	OFF: Microprocessor error, memory error, etc. Refer to chapter 3 for further information.
	ERR	Visual check	OFF	ON: Serious errors such as microprocessor error or memory error, etc. Refer to chapter 3. Blink: Battery error (71 error)
	7-segment	Visual check	00	Self-diagnosis error code is displayed. Refer to chapter 3.

*1 If power off time is more than 1 week after battery error detected (ERR LED blinking), retain data and realtime clock data could be lost due to battery empty. If power off time is long enough, it is possible that a battery becomes empty while this power failure. In that case, retain data and realtime clock data would be already lost in the next power up.

(2) Periodic inspection

Turn off the power for the external I/O circuit, and check the following items once every six months.

Table 5.1-2 Items for periodic inspection

Part	Item	Check criteria	Remarks
Programming device to CPU	Check the operation of the programming device	All switch and display lamps work properly.	
Power supply	Check for the voltage fluctuations	85 to 264 V AC	Tester
I/O module	Output relay life	Electrical life 200,000 times Mechanical life 10 million times	Refer to the relay contact file curve (chapter 4).
	LED	Turns ON/OFF correctly	
	External power voltage	Within the specification for each I/O module.	Refer to the specifications of I/O module
Battery (Lithium battery)	Check voltage and life	ERR lamp flashes. Within 2 years after replacement.	
Installation and connecting areas	(1) All module are securely fixed. (2) All command fits snugly. (3) All screw is tight. (4) All cables are normal.	No defects	Tighten Check insertion Tighten Visual check
Ambient environment	(1) Temperature (2) Humidity (3) Others	0 to 55 °C 5 to 95 % RH (no condensation) No dust, foreign matter, vibration	Visual check
Spare part	Check the number of parts, the storage condition	No defects	Visual check
Program	Check program contents	Compare the contents of the latest program saved and CPU contents, and make sure they are the same.	Check both master and backup.

5.2 Product Life

The lifetime of electrolytic capacitors used in the power module is limited. Electrolytic capacitors are used in some of I/O modules to improve noise resistance. If the lifetime is exceeded, performance of product is not guaranteed. Be sure to conduct inspection and maintenance as follows.

(1) Power module

Many electrolytic capacitors are used in the power module. It is said that lifetime of electrolytic capacitor would be half when ambient temperature increases 10 °C.

If lifetime of electrolytic capacitor is exceeded, output power becomes unstable especially when output current is high due to many point of outputs are activated for example.

Prepare spare units with considering 5 years lifetime in case ambient temperature is 30°C. For longer lifetime, take account of installation location in terms of temperature and air circulation around power unit and.

(2) CPU module

Some electrolytic capacitors are used in CPU module also. If lifetime of electrolytic capacitor is exceeded, more errors could happen since noise resistance is not enough. Be sure to overhaul CPU module periodically.

CPU module has a battery to maintain realtime clock data and retain memory. Be noted following points about lifetime of battery.

- The battery life as shown below is total power failure time of PLC.
- When ERR LED blinks and error code 71 is displayed, replace a battery to new one.

As a guideline, replace a battery every two years even when the total power failure time is less than the guaranteed value shown in the table.

Battery life (Total power failure time)[Hr]	
Guaranteed value (MIN) @55°C	Actual value (MAX) @25°C
2,000	17,700

How to replace the battery

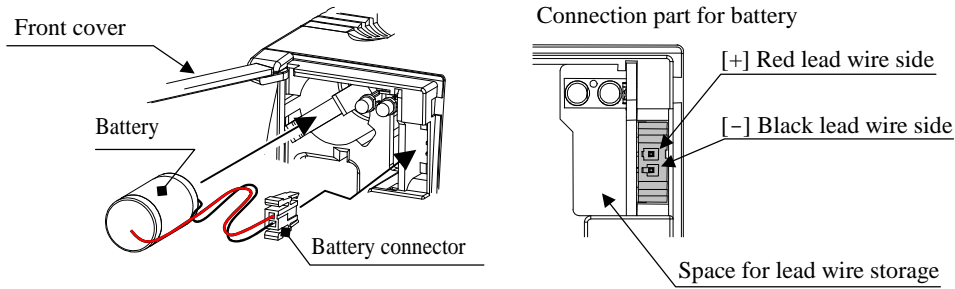

Do not open the front cover more than 90 degree when installing and removing the battery.

Figure 5.2-1 How to replace the battery

- 1] Prepare a new battery (LIBAT-H).
 - 2] Confirm that the latest program is saved in your PC. If not, it is recommended to save for safety.
 - 3] Power of PLC does not have to be removed while replacing battery.
 - 4] Remove the old battery from the battery case and disconnect the battery cable from CPU.
 - 5] Connect battery cable of new battery to CPU. (Red cable is (+) and black is (-)).
 - 6] Fold the excess lead wire and store it in the space for lead wire storage. (Otherwise, the wire may be damaged by the front cover.)
- * If replacing the battery without power supplied, power off time should be less than 1 minute.

⚠ DANGER

Precaution when handling the battery.

Use LIBAT-H for the new battery. Be careful because a false replacement may cause the battery to explode.

Do not connect + and - of the battery reversely, charge them, take them apart, heat them, throw them into the fire, short them.

⚠ CAUTION

Disposal (collection) of the battery

Old battery should be individually put in plastic bag or similar (to prevent short circuit and a disposal company should be requested to dispose of them).

MEMO

Appendix Known Restrictions

Below restrictions are known in EHV-CODESYS V3.5 SP3 Patch6 and EHV+ series CPU.

1. Copying a file in [Files] window

As an optional function, it is possible to send files in [Files] tab in Device window as below, but it does not work properly with EHV-CODESYS V3.5 SP3 Patch6. If attempting to copy a file from PC to PLC in [Files] tab of [Device] window, it fails with an error message as below. Instead of this function, use “Login” or “Create boot project”.

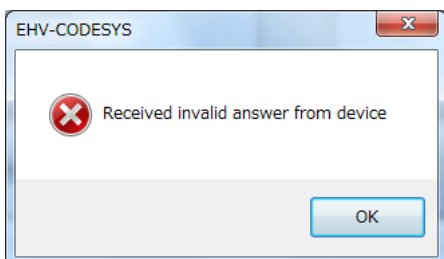
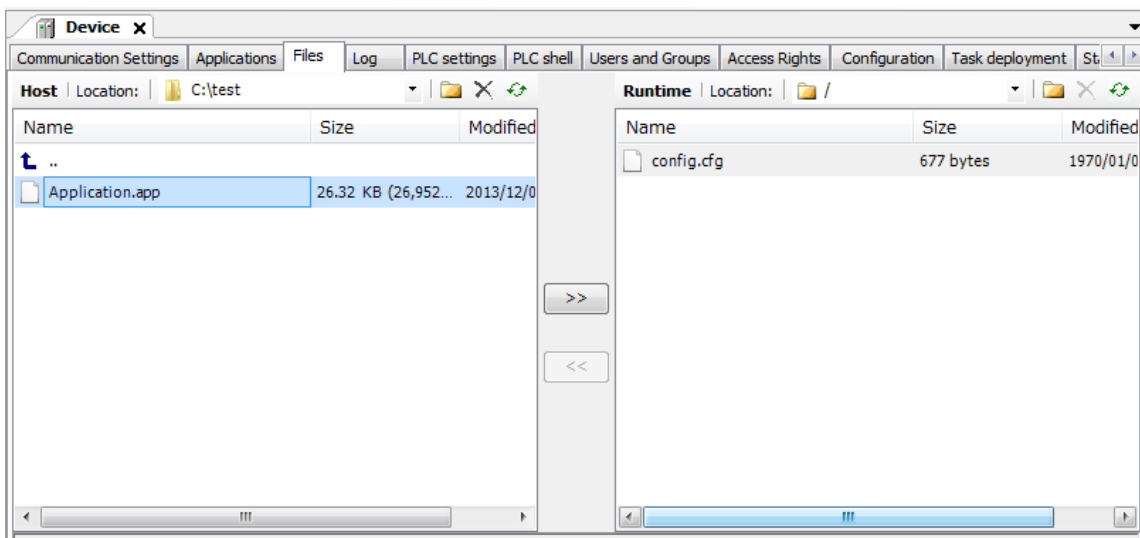

2. Add gateway button

If you click [Scan network] and delete the gateway before scanning completed, warning dialog box appears. After clicking [OK], [Add gateway] button will be deactivated. Choose [Add gateway] in right mouse click menu or close and open the Device window to enable [Add gateway] button again.

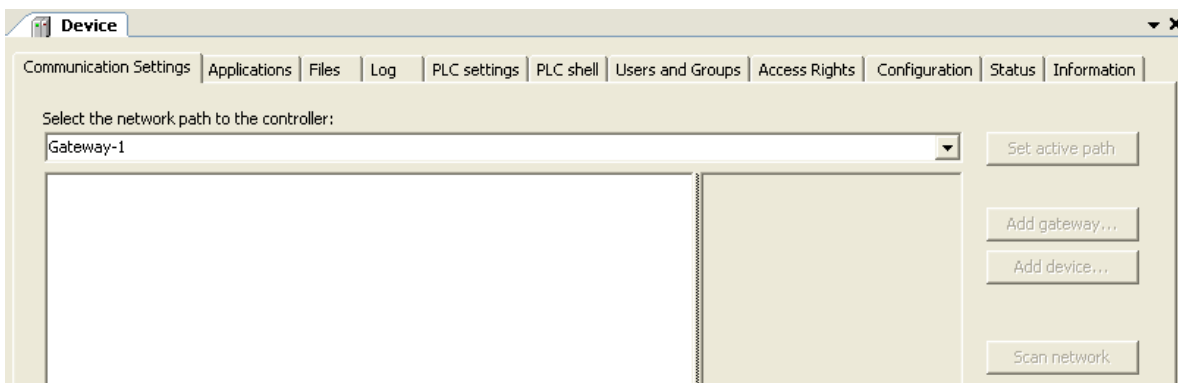

3. Replace

“Selection only” of Replace function does not work properly. Searched words in not only selected part but out of the part is replaced also. Use [Replace All] function instead of [Replace].

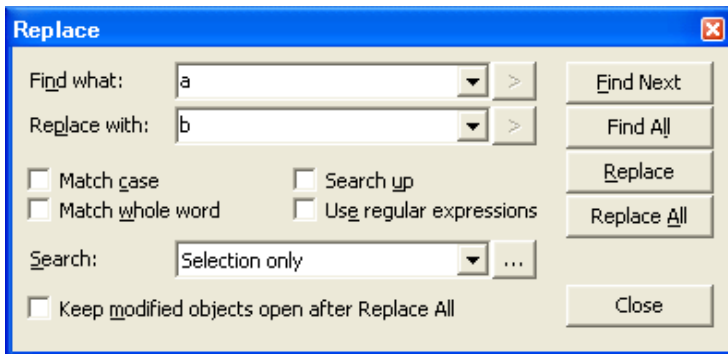

4. USB communication

If Ethernet communication load is heavy (for example, hundreds of variables on HMI/OPC), below phenomena could be found in USB communication with EHV-CODESYS.

- Slow updating cycle of monitored variables (several seconds).
- Fail to communication sometimes.

To avoid above mentioned phenomena, please use the Ethernet port instead of USB.

5. Outputs ON while in stop

If CPU ROM VER.3.4.x.x is operated as below, output signals do not shut down while CPU in stop. This problem has been fixed in CPU ROM VER.3.5.x.x.

- (1) EHV-CODESYS V3.5 SP3 Patch6 is used and compiler version 3.5.3.60 (default) is selected.

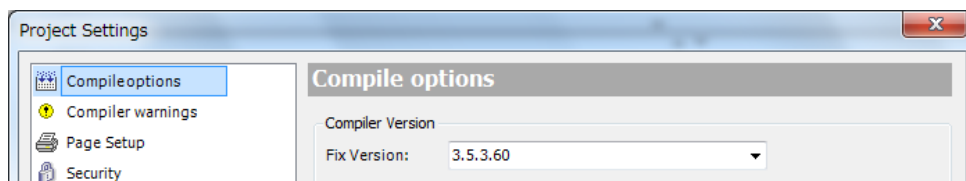

- (2) Variable names are not used for outputs. (PLC addresses are written directly in POU's)

```
%QX1.0:=TRUE; // Bit-0 of Digital output in Slot-0
```

- (3) Online change

or

Create boot application from [Online] menu.

- (4) Cycle power

- (5) Toggle RUN/STOP switch from RUN to STOP (Stop switch definition = Reset warm (default))

or

Reset warm or Reset cold from [Online] menu

- (6) PLC goes to STOP mode, but output signals do not shut down.

Take the countermeasure (a) or (b) as below.

- (a) Choose different compiler version than 3.5.3.60.

- (b) Put variable names for outputs instead of direct addresses in POU.

Note: Outputs can be defined as global or local variable.

Variable name in POU

```
Test:=TRUE; // Bit-0 of Digital output in Slot-0
```

Output as global variable

16 Digital Output I/O Mapping			
Variable	Mapping	Channel	Address
			%QW0
test		Bit0	%QX1.0

Output as local variable

```
PROGRAM PLC_PRG
VAR
test AT %QX1.0: BOOL;
END_VAR
```

MEMO