



**MICRO-EH (20/40/64 points type basic unit) Safety Precautions**

Thank you for purchasing a Hitachi Programmable Logic Controller. To operate it safely, please read these safety precautions and all the user manuals carefully. Please be sure to use the latest versions of the user manuals and keep them at hand of end users for future reference.

**Caution**

1. It is not allowed to reprint any part of this manual without permission.
2. The content of this manual may be changed without notice.
3. While efforts have been made on this manual to be accurate, please contact us if any mistakes or unclear part is found.

**Warranty period and coverage**

The warranty period is either 18 months after manufacturing date (MFG No) or 12 months after installation. Examination and repair within the warranty period is covered. However within the warranty period, the warranty will be void if the fault is due to;

- (1) Incorrect use as directed in this manual and the application manual.
- (2) Malfunction or failure of external other devices than this unit.
- (3) Attempted repair by unauthorized personnel.
- (4) Natural disasters.

The warranty is for the PLC only, any damage caused to third party equipment by malfunction of the PLC is not covered by the warranty.

**Repair**

Any examination or repair after the warranty period is not covered. And within the warranty period any repair and examination which results in information showing the fault was caused by any of the items mentioned above, the repair and examination cost are not covered. If you have any questions regarding the warranty or repair cost, please contact your supplier or the local Hitachi Distributor. (Depending on failure part, repair might be impossible.)

**Reference Manual**

Read the following application manual carefully to use the PLC safely and properly. Be sure to keep the latest version

Manual name	Manual number
MICRO-EH APPLICATION MANUAL	NJI-350(X)
MICRO-EH BASIC UNIT(20/40/64 points type) APPLICATION MANUAL	NJI-465(X)

The postfix of the publication number is subject to change for revision.

**General cautions**

**Definitions and Symbols**

- DANGER** Indicates a potentially hazardous situation which, if not avoided, can result in serious injury or death.
- CAUTION** Indicates a potentially hazardous situation which, if not avoided, can result in minor to moderate injury, or serious damage of product.
- : Indicates prohibition
- : Indicates Compulsion

**DANGER**

- Do not touch terminals during power ON. Failure to observe this caution may cause personal injury.
- Be sure to install external safety devices outside of the PLC like emergency stop circuit or interlock circuit.

**CAUTION**

- Always use the rated power voltage according to the module specifications. Using other voltages may damage the equipment or cause personal injury or fire.
- Only qualified personnel shall carry out wiring work. Failure to observe this caution may damage the equipment or cause personal injury or fire.

**COMPULSION**

- Be sure to ground the unit. Failure to do so may cause malfunction.

**PROHIBITION**

- Do not attempt to disassemble, repair or modify any part of the PLC. Failure to observe this caution may cause fire or damage of the equipment or malfunction.

## Mounting

- This equipment must be placed within a suitable enclosure such as a cabinet (key or tool entry) .
- Mount the PLC on a metal plate and install in a cabinet as follows.
- Be sure to ground the cabinet and the metal plate, otherwise there is a risk of malfunction.
- Install the PLC as described in user manual.
- Take appropriate measures when installing systems in locations :
  - Subject to static electricity or other forms of noise.
  - Subject to strong electromagnetic field.
  - Close to power supplies.
- Be sure to tighten mounting screws, terminal screws and connector screws.
- Check if devices with lock mechanism, such as an expansion cable and terminal blocks, are locked properly.

### ■ Power Wiring Procedures

- Appropriate emergency circuitry, interlock circuitry and similar safety measures should be added to the system.
- Appropriate safety measures should be included in the system to ensure safety in the event of abnormal signals caused by broken wires or momentary power interruptions.
- Always use the rated power voltage according to the manual. Using other voltages may damage the equipment or cause personal injury or fire.
- Install an external earth leakage breakers to avoid short circuit accident.
- Always turn off the power supply to the PLC before attempting any of the following. Performing any of these acts may result in damage to the PLC or personal injury or malfunction.
  - Mounting or dismounting the basic or expansion unit.
  - Assembling the equipment.
  - Wiring.
- Install net filter specified in table-1. The input and output cable of the net filter should be separated as much as possible. Be sure to ground the net filter.
- A shielded and insulated transformer is recommended.
- The basic and expansion unit should be wired to a common power source and powered up together as shown in fig.1.
- Install a lightning arrester  
To prevent damage to the equipment as a result of being struck by lightning, it is recommended that a lightning arrester be installed for each PLC's power supply circuit.

Table1 Net filter

Item	Spec.	
Rated voltage	250 V	
Rated current	5 A	
Withstand voltage (V) (between Terminal and case)	1500 V	
Insulation resistance (MΩ) (500VDC, 1 min., between terminal and case)	min. 100 MΩ	
Attenuation frequency range (MHz)	Differential mode, 40dB	0.5 to 30
	Common mode, 40dB	0.15 to 30

Reference : EMC filter ZAC2205-00U (TDK)

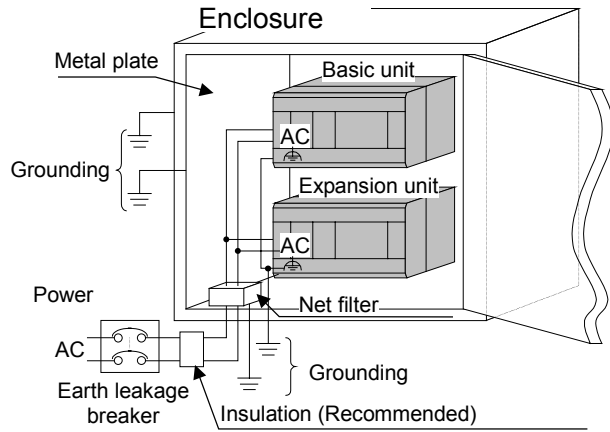

Figure 1 Power wiring example

### ■ I/O Wiring Procedures

- Always use the rated input/output voltage according to the module specifications. Using other voltages may damage the equipment or cause personal injury or fire.
- Install AC power cables in separate cable trays or bunches from I/O signal or data lines.
- Route the I/O lines and data lines as close as possible to the grounded surfaces such as cabinet elements, metal bars and cabinets panels.

### ■ General Wiring Procedures

- Use copper conductors for all wiring. You can use one copper conductor – AWG#14 (2.1 mm<sup>2</sup>) through AWG#22 (0.36 mm<sup>2</sup>) or two copper conductors – AWG#16 (1.3 mm<sup>2</sup>) through AWG#22 (0.36 mm<sup>2</sup>) – per terminal.
- The suggested torque for terminal connections is 0.5 to 0.6 Nm.
- Use proper cable ferrules for terminals. Using improper cable ferrules or connecting bare wires to terminals directly might result in fire.
- Do not turn on the power supply to a broken PLC.
- Be sure to check all wiring before applying the power. Incorrect wiring may damage the equipment or cause fire.
- Do not attempt to disassemble, repair or modify any part of the PLC.
- Do not pull on cables or bend cables beyond their natural limit. The lines may break.
- Check carefully your PLC program before using.
- Keep PLC modules in their boxes during storage and transport.

## Environmental Conditions

- Avoid the following locations to install the PLC.
- Excessive dust, salty air, or conductive materials. (iron powder, etc.)
  - Direct sunlight.
  - Temperature less than 0°C or more than 55°C.
  - Humidity less than 5% or more than 95%.
  - Dew condensation.
  - Direct vibration or impact to the unit.
  - Corrosive, explosive or combustible gases.
  - Water, chemicals or oil splashing on the PLC.
  - Close to noise emission devices.

■ Terminal layout and wiring (20 Points type)

EH-A20DR (AC power type)

\* For the DC input, both sink and source type are available. It is possible to reverse the polarity of 24VDC.

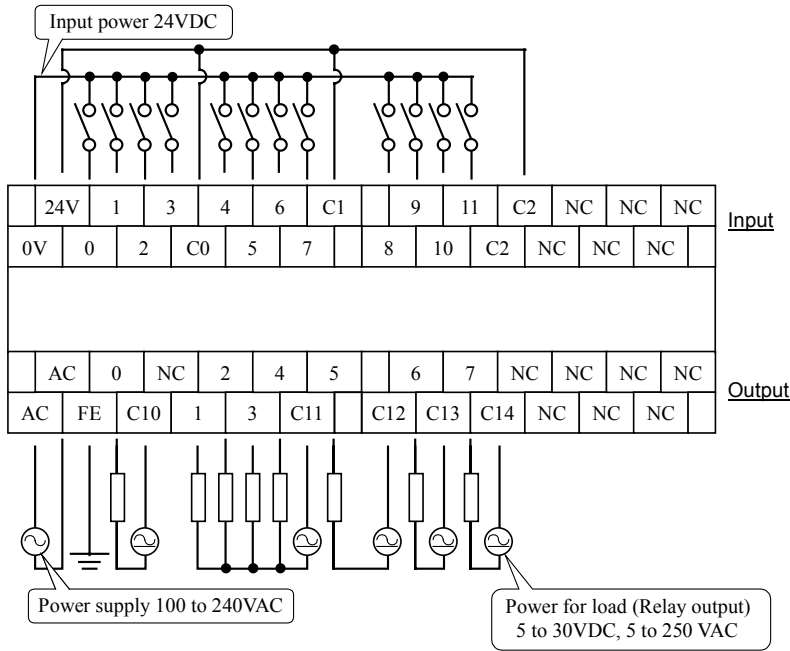

EH-D20DR (DC power type) (Input wiring is same as EH-A20DR)

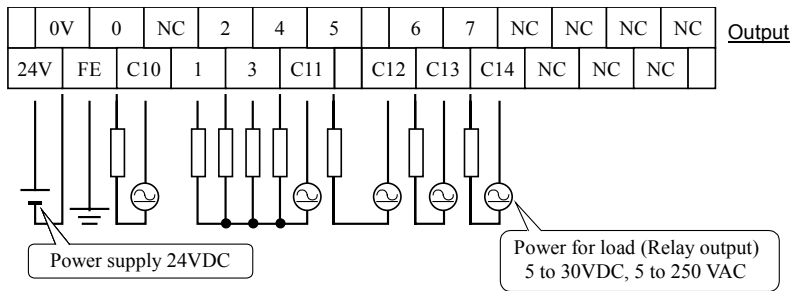

EH-D20DTPS (DC power type) (Input wiring is same as EH-A20DR)

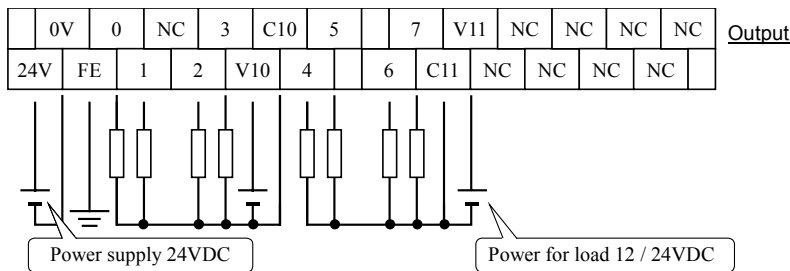

EH-D20DT (DC power type) (Input wiring is same as EH-A20DR)

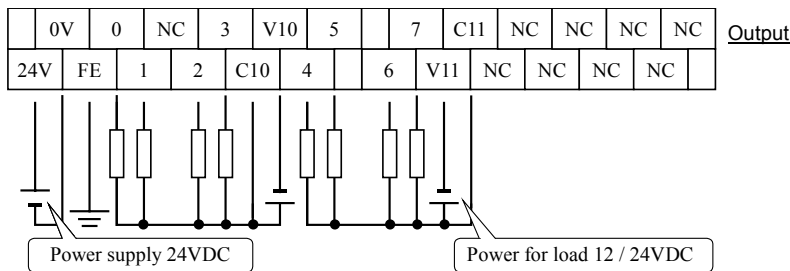

■ Terminal layout and wiring (40 Points type)

EH-A40DR (AC power type)

\* For the DC input, both sink and source type are available. It is possible to reverse the polarity of 24VDC.

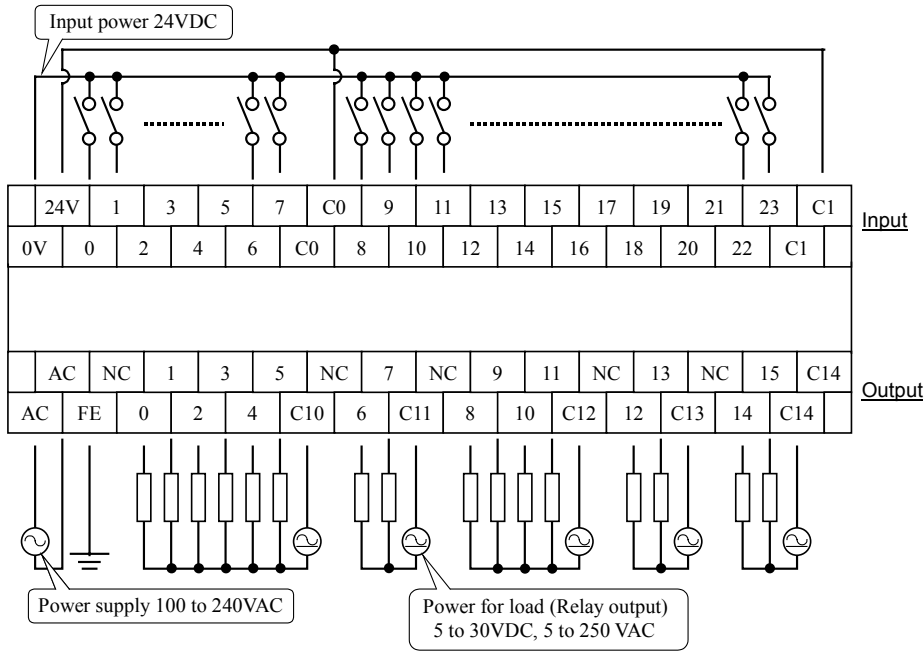

EH-D40DR (DC power type) (Input wiring is same as EH-A40DR)

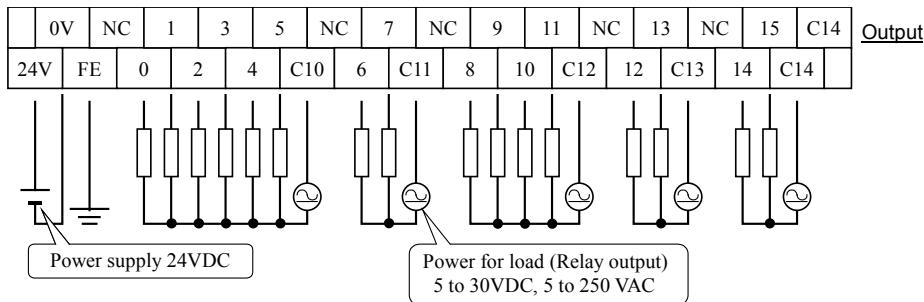

EH-D40DTPS (DC power type) (Input wiring is same as EH-A40DR)

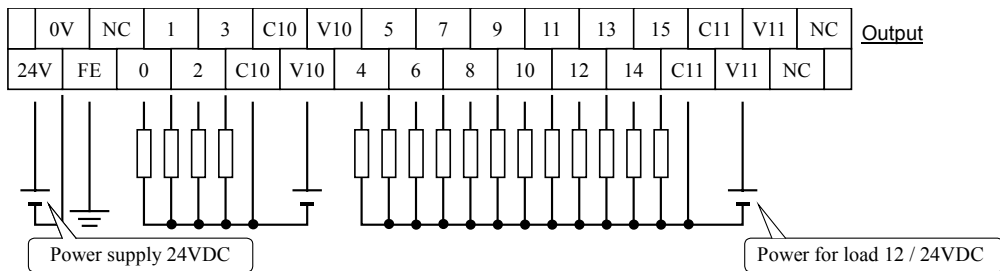

EH-D40DT (DC power type) (Input wiring is same as EH-A40DR)

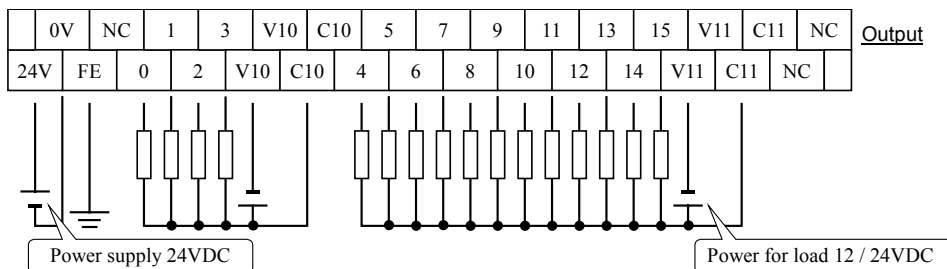

■ Terminal layout and wiring (64 Points type)

EH-A64DR (AC power type)

\* For the DC input, both sink and source type are available. It is possible to reverse the polarity of 24VDC.

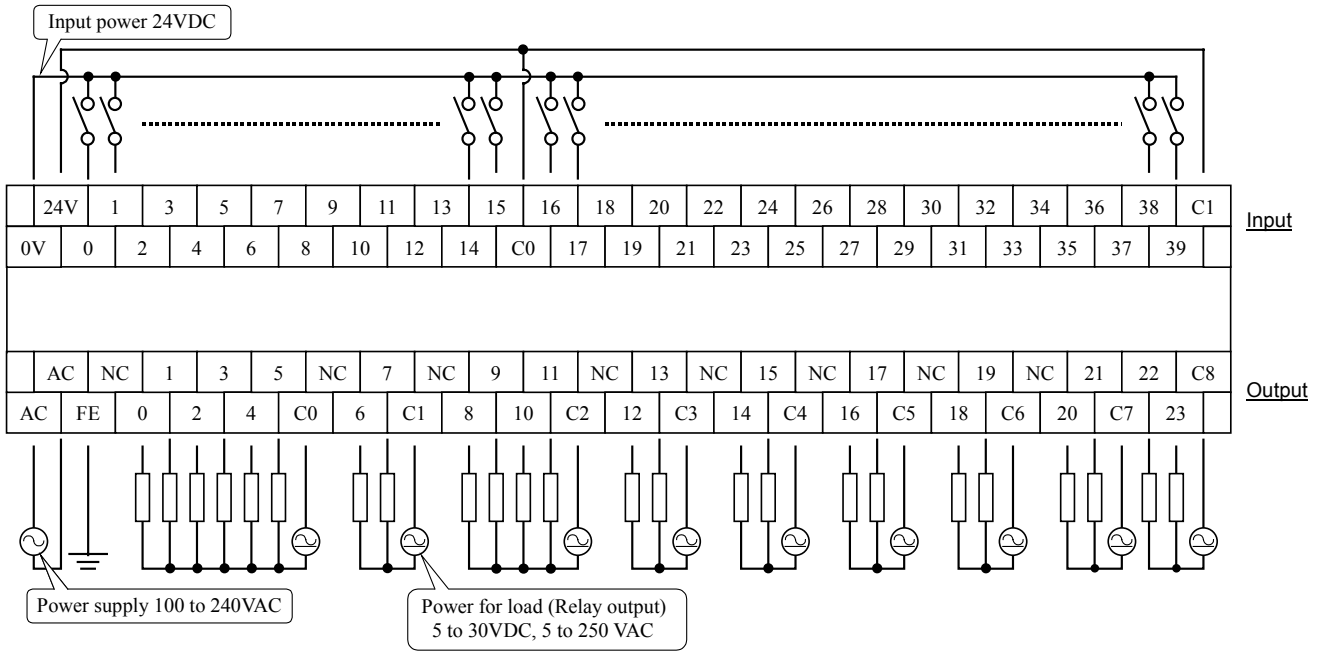

EH-D64DR (DC power type) (Input wiring is same as EH-A64DR)

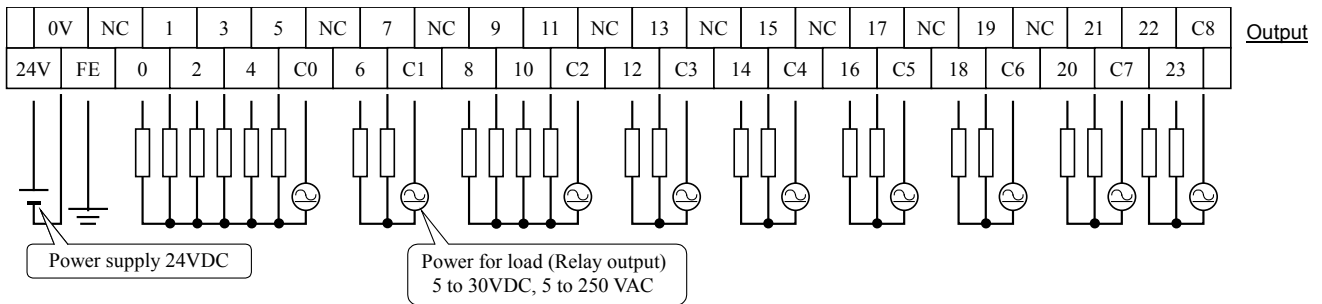

EH-D64DTPS (DC power type) (Input wiring is same as EH-A64DR)

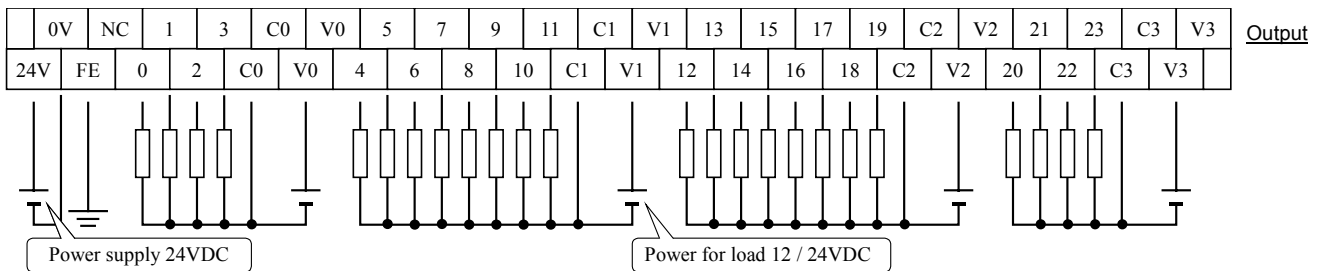

EH-D64DT (DC power type) (Input wiring is same as EH-A64DR)

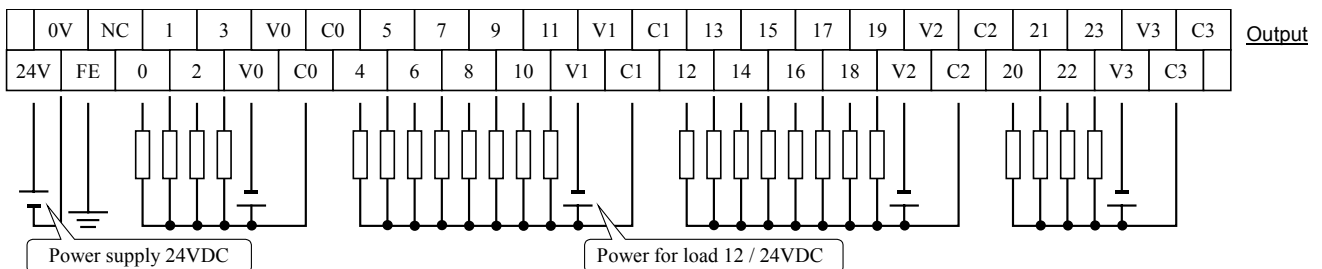

■ NOTE

▪ **Communication with peripheral devices**

The baud rate of Port 1 is set by DIP switch in PLC. When the PLC communicates with peripheral devices, DIP switch in PLC must consist with the baud rate of them.

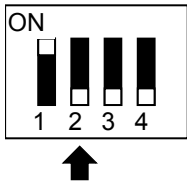

SW No.	1	2	3	4	Setting	Remark
DIPSW	ON	OFF	ON	OFF	38.4 kbps	
	<b>ON</b>	<b>OFF</b>	<b>OFF</b>	<b>OFF</b>	<b>19.2 kbps</b>	<b>Factory setting</b>
	OFF	OFF	ON	OFF	9600 bps	
	OFF	OFF	OFF	OFF	4800 bps	
	OFF	ON	OFF	OFF	Modem connection	

Setting of Dip switch

The baud rate of Port 1 is 19.2k bps at factory setting.

Portable graphic programmer (PGM-GPH) and command language programmer (PGM-CHH) are not supported by MICRO-EH. When you use LADDER EDITOR DOS version, set DIP switch all OFF to be baud rate 4,800 bps.

▪ **CPU initialization**

When you use the PLC first time, be sure to initialize by programming software because data memory could be uncertain status.

▪ **Program memory capacity**

Program step size of 20/40/64-point MICRO-EH is 16 k steps.

▪ **Transmission to FLASH memory**

When user program is downloaded from PC to PLC, it is stored in SRAM memory. (Program downloading is completed at this timing.) After that, it is written to FLASH memory, which takes about 3 minutes. If power supply is removed while this timing, user memory error (31H) will be detected at the next power ON. For this reason, do not remove the power supply in 3 minutes after downloading.

[ Note ] When FLASH memory is being written, internal output R7EF is 1.

In case of MICRO-EH 64-point type, OK LED flashes every 2 seconds when FLASH memory is being written.

▪ **Setting the transmission procedure**

Protocol of MICRO-EH can be changed in WRF01A. But once Port 1 is set for transmission procedure 2 and written to the FLASH memory\*, the PLC will accept only the transmission procedure 2 from next power ON. Therefore, peripheral deceives or programming software such as LADDER EDITOR, which support only transmission procedure 1, are not able to communicate with the PLC via Port 1. In this case, please contact either your supplier or the local HITACHI Distributor.

\* If special register (R7F6) is set, each parameter will be written to FLASH memory.

After the host transmits the negative acknowledge command (NAK), please wait more than 10 ms to transmit the next text data.

▪ **UL requirements**

This unit is industrial control equipment for use in hazardous locations “class 1, Division 2. Groups A, B, C, and D”.

- WARNING: EXPLOSION HAZARD – SUBSTITUTION OF ANY COMPONENTS MAY IMPAIR SUITABILITY FOR CLASS I, DIVISION 2.
- WARNING: EXPLOSION HAZARD – DO NOT REPLACE MODULES UNLESS POWER HAS BEEN SWITCHED OFF OR THE AREA IS KNOWN TO BE NON-HAZARDOUS.
- WARNING: EXPLOSION HAZARD – DO NOT CONNECT OR DISCONNECT EQUIPMENT UNLESS POWER HAS BEEN SWITCHED OFF OR THE AREA IS KNOWN TO BE NON-HAZARDOUS.
- WARNING: EXPLOSION HAZARD – DO NOT CONNECT OR DISCONNECT CABLE UNLESS POWER HAS BEEN SWITCHED OFF OR THE AREA IS KNOWN TO BE NON-HAZARDOUS.
- WARNING: Fire, Explosion, and Severe Burn Hazard. Do Not Recharge, Disassemble, Heat Above 212°F (100°C), Incinerate, Or Expose Contents To Water.
- Battery: If you use retentive data or real-time clock, use an optional battery EH-MBAT for 23/28-point type or EH-MBATL for 20/40/64-point type.
- RECOMMENDATION - If PLC is used in chemical environment, it could affect and degrade relay devices. it is recommended to inspect the sealed relay device periodically and to check for any degradation of the materials and to replace the complete product, not the sealed device, if any degradation is found.